



GOLD'S GYM[®]

XR 5.9

www.workoutwarehouse.com

Model No. GGBE4869.11

Serial No. _____

Write the serial number in the space above for reference.

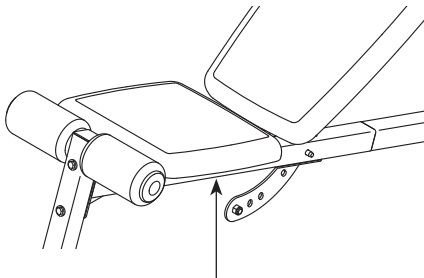

Serial Number Decal (under seat)

ACTIVATE YOUR WARRANTY

To register your product and activate your warranty today, go to www.workoutwarehouse.com/registration.

CUSTOMER CARE

For service at any time, go to www.workoutwarehouse.com.

Or call 1-877-776-4777
Mon.–Fri. 6 a.m.–6 p.m. MT
Sat. 8 a.m.–12 p.m. MT

Please do not contact the store.

⚠ CAUTION

Read all precautions and instructions in this manual before using this equipment. Keep this manual for future reference.

USER'S MANUAL

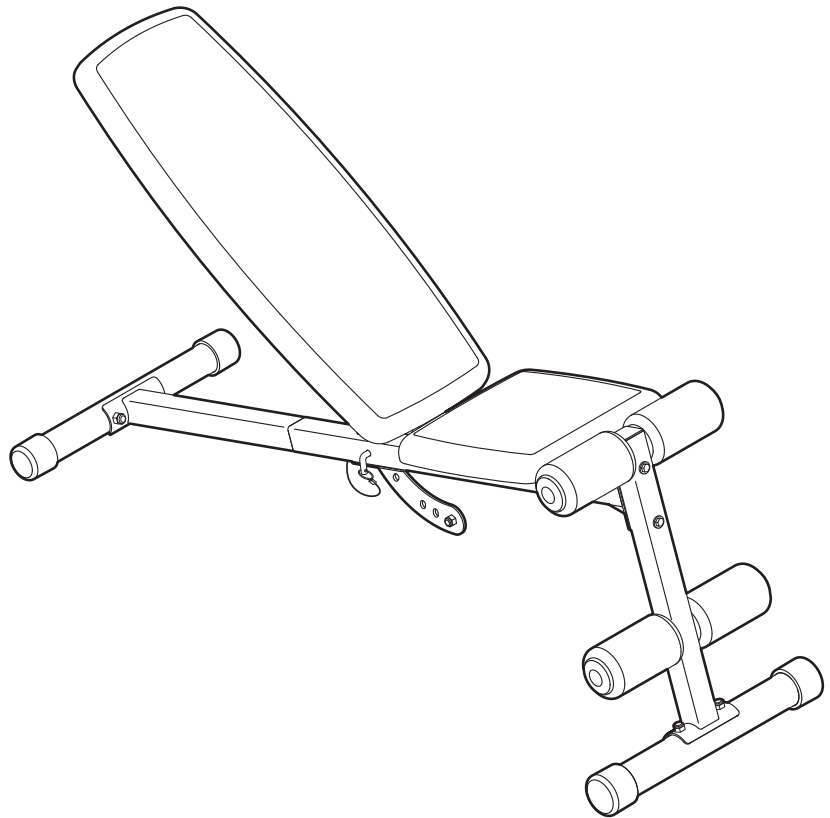

TABLE OF CONTENTS

WARNING DECAL PLACEMENT2

IMPORTANT PRECAUTIONS.....3

BEFORE YOU BEGIN.....5

PART IDENTIFICATION CHART.....6

ASSEMBLY.....7

ADJUSTMENT11

EXERCISE GUIDELINES12

PART LIST.....14

EXPLODED DRAWING.....15

ORDERING REPLACEMENT PARTS Back Cover

LIMITED WARRANTY..... Back Cover

WARNING DECAL PLACEMENT

This drawing shows the location(s) of the warning decal(s). **If a decal is missing or illegible, see the front cover of this manual and request a free replacement decal. Apply the decal in the location shown.** Note: The decal(s) may not be shown at actual size.

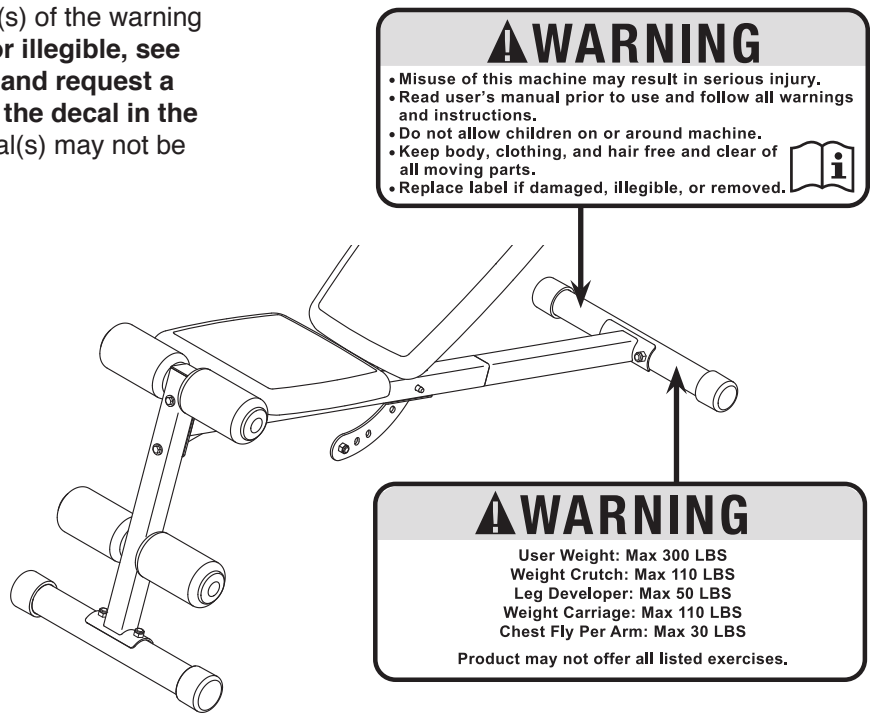

IMPORTANT PRECAUTIONS

⚠ WARNING: To reduce the risk of serious injury, read all important precautions and instructions in this manual and all warnings on your weight bench before using your weight bench. ICON assumes no responsibility for personal injury or property damage sustained by or through the use of this product.

1. It is the responsibility of the owner to ensure that all users of the weight bench are adequately informed of all precautions.
2. Before beginning any exercise program, consult your physician. This is especially important for persons over age 35 or persons with pre-existing health problems.
3. The weight bench is not intended for use by persons with reduced physical, sensory, or mental capabilities or lack of experience and knowledge, unless they are given supervision or instruction about use of the weight bench by someone responsible for their safety.
4. Read all instructions in this manual and all warnings on the weight bench before using the weight bench.
5. The weight bench is intended for home use only. Do not use the weight bench in a commercial, rental, or institutional setting.
6. Keep the weight bench indoors, away from moisture and dust. Do not put the weight bench in a garage or covered patio, or near water.
7. Place the weight bench on a level surface, with a mat beneath it to protect the floor or carpet. Make sure that there is enough clearance around the weight bench to mount, dismount, and use the weight bench.
8. Inspect and properly tighten all parts each time the weight bench is used. Replace any worn parts immediately.
9. Keep children under age 13 and pets away from the weight bench at all times.
10. The weight bench is designed to support a maximum user weight of 300 lbs. (136 kg) and a maximum total weight of 410 lbs. (186 kg). Do not use more than 110 lbs. (50 kg) of weight with the weight bench. Note: The weight bench does not include weights.
11. Always wear athletic shoes for foot protection while using the weight bench.
12. Always make sure that the locking pin is fully inserted into the frame and into the pivot bracket before you use the weight bench.
13. Over exercising may result in serious injury or death. If you feel faint, if you become short of breath, or if you experience pain while exercising, stop immediately and cool down.

PROTECT

YOUR FITNESS EQUIPMENT
WITH AN EXTENDED SERVICE PLAN

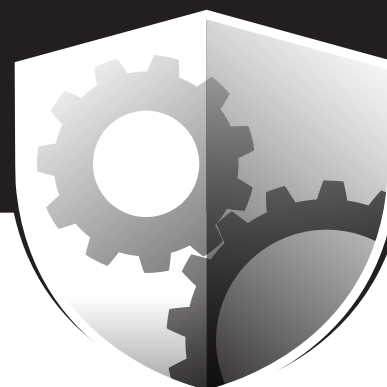

Your new fitness equipment is not an ordinary purchase; it is an investment in your health and well being for years to come.

As the leading provider of manufacturer's extended service plans, ICON strives to protect your equipment and your future.

Please review the following service plans and find one that best fits your needs.

PREVENTIVE MAINTENANCE SERVICE PLANS

Equipment Price	3-Year Plan	5-Year Plan
\$0.00 to \$1000.00	\$199.99	\$289.99
\$1001.00 to \$1500.00	\$259.99	\$379.99
\$1501.00 to \$2500.00	\$339.99	\$489.99
(Bikes/Systems Only) \$0.00 to \$2500.00	\$139.99	NA

Features:

- Includes an annual preventive maintenance and performance check at your convenience
- Unlimited in-home repairs; no shipping required
- Covers parts and labor on all manufacturer's defects, as well as wear and tear on parts
- Up to 5 years of coverage available

STANDARD SERVICE PLANS

Equipment Price	1-Year Plan	2-Year Plan	3-Year Plan
\$0.00 to \$300.00	\$29.99	\$39.99	\$59.99
\$301.00 to \$1000.00	\$89.99	\$119.99	\$149.99
\$1001.00 to \$2000.00	\$109.99	\$139.99	\$179.99
\$2001.00 to \$3000.00	\$179.99	\$209.99	\$239.99

Features:

- Unlimited in-home repairs; no shipping required
- Covers parts and labor on all manufacturer's defects, as well as wear and tear on parts
- Up to 3 years of coverage available

To protect your fitness equipment today, please
call Customer Care at **1-800-677-3838.**
Or, visit us online at **www.utserv.com.**



BEFORE YOU BEGIN

Thank you for selecting the versatile GOLD'S GYM® XR 5.9 weight bench. The XR 5.9 weight bench is designed to help develop the major muscle groups of the upper body. Whether your goal is to tone your body, build dramatic muscle size and strength, or improve your cardiovascular system, the weight bench will help you to achieve the specific results you want.

For your benefit, read this manual carefully before using the weight bench. If you have questions after

reading this manual, please see the front cover of this manual. To help us assist you, note the product model number and serial number before contacting us. The model number and the location of the serial number decal are shown on the front cover of this manual.

Before reading further, please look at the drawing below and familiarize yourself with the parts that are labeled.

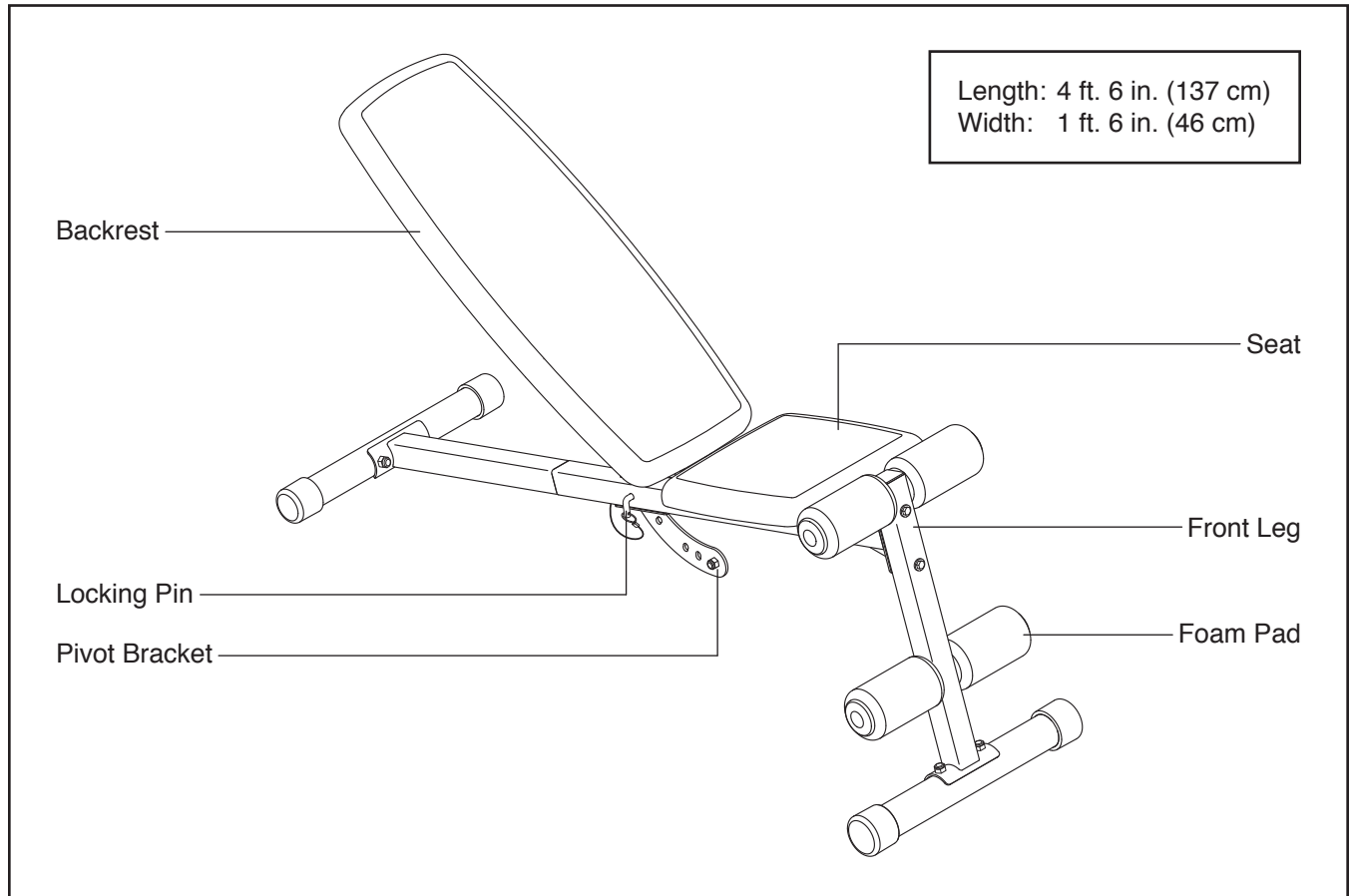

PART IDENTIFICATION CHART

Use the drawings below to identify small parts used in assembly. The number in parentheses by each drawing is the key number of the part, from the PART LIST near the end of this manual. **Note: If a part is not in the hardware kit, check to see if it has been preattached.**

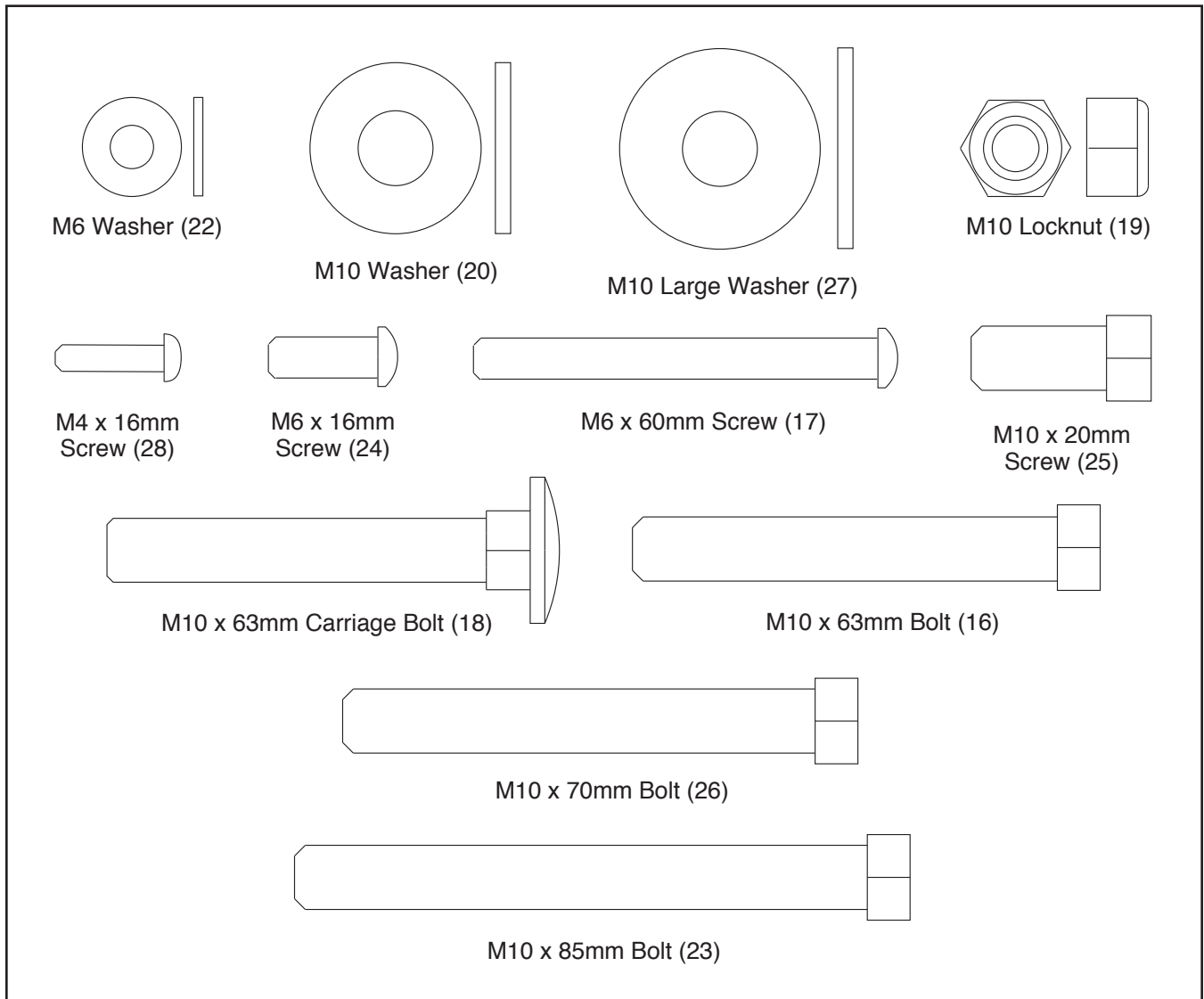

ASSEMBLY

- To hire an authorized service technician to assemble the weight bench in your home, call 1-800-445-2480.
- Assembly requires two persons.
- Because of its size and weight, assemble the weight bench in the location where it will be used. Make sure that there is enough clearance to walk around the weight bench as you assemble it.
- Place all parts in a cleared area and remove the packing materials. Do not dispose of the packing materials until you finish all assembly steps.
- Left parts are marked “L” or “Left” and right parts are marked “R” or “Right.”

- To identify small parts, see page 6.
- The following tools (not included) may be required for assembly:

two adjustable wrenches



one rubber mallet



one standard screwdriver

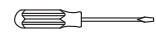

one Phillips screwdriver

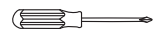

Assembly may be easier if you have your own set of wrenches. To avoid damaging parts, do not use power tools.

1. **Go to www.workoutwarehouse.com/ registration on your computer and register your product.**

- activates your warranty
- saves you time if you ever need to contact Customer Care
- allows us to notify you of upgrades and offers

Note: If you do not have internet access, call Customer Care (see the front cover of this manual) and register your product.

2. Identify the Front Stabilizer (29), which does **not** have warning decals.

Attach the Front Stabilizer (29) to the Front Leg (2) with two M10 x 63mm Carriage Bolts (18) and two M10 Locknuts (19). **Do not tighten the Locknuts yet.**

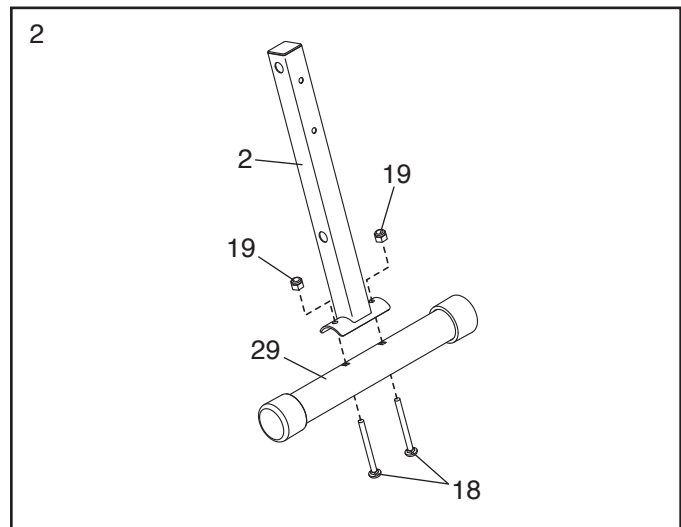
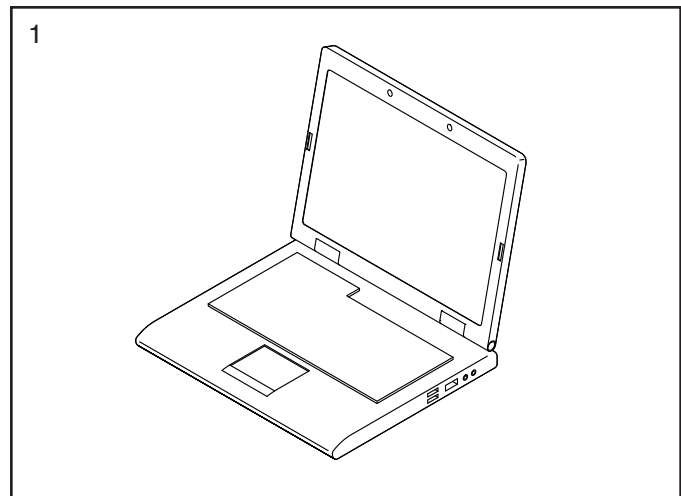

3. Attach the Front Leg (2) to the Frame (1) with two M10 x 63mm Bolts (16), two M10 Large Washers (27), and two M10 Locknuts (19). **Do not tighten the Locknuts yet.**

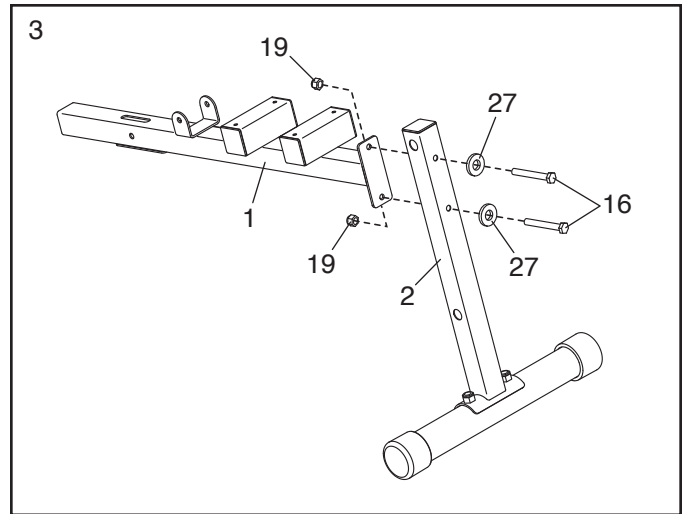

4. Orient the Rear Stabilizer (4) so that the warning decals face upward. Next, orient the Rear Leg (3) as shown.

Attach the Rear Stabilizer (4) to the Rear Leg (3) with two M10 x 63mm Carriage Bolts (18) and two M10 Locknuts (19). **Do not tighten the Locknuts yet.**

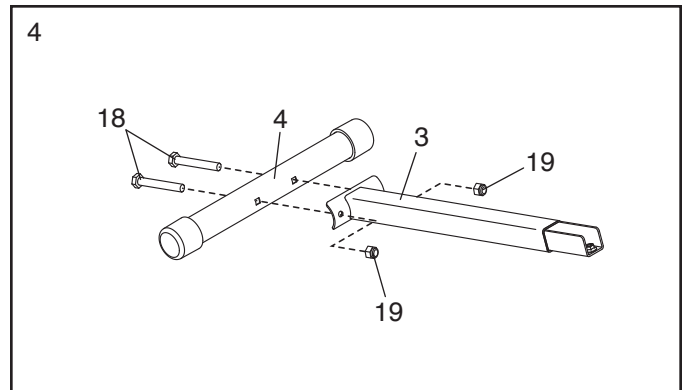

5. Attach the Rear Leg (3) to the Frame (1) with two M10 x 20mm Screws (25) and two M10 Washers (20).

See steps 2–4. Tighten the M10 Locknuts (19).

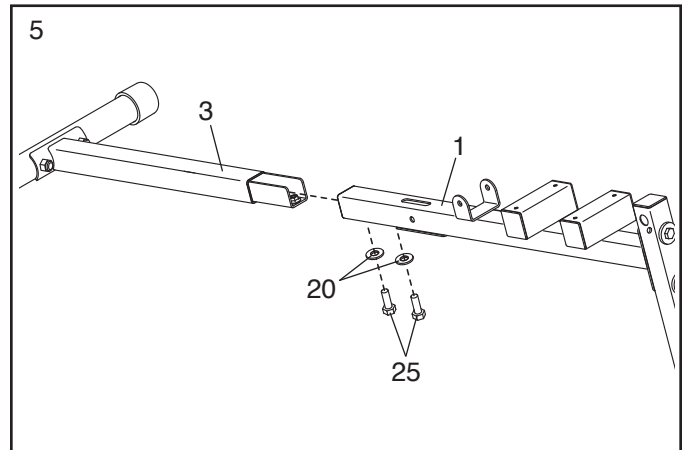

6. Insert the two Pad Tubes (10) into the Front Leg (2).

Wet the ends of the Pad Tubes (10) with soapy water, and slide two Foam Pads (9) onto each Pad Tube.

Then, press two Pad Caps (11) into each Pad Tube (10).

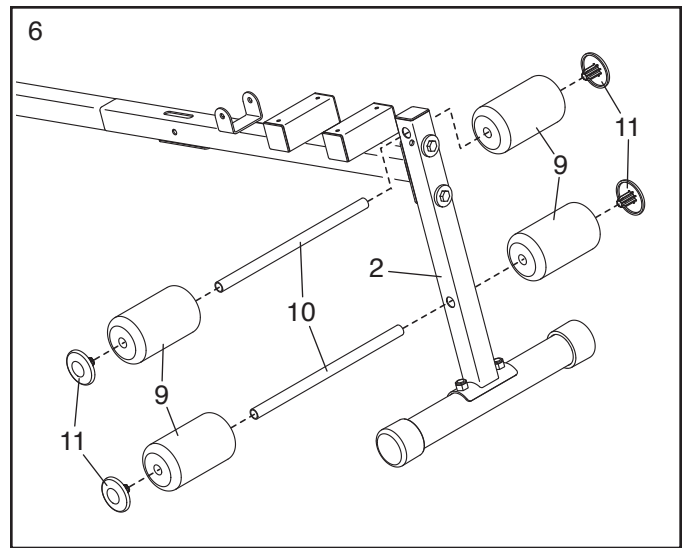

7. Attach the Pivot Bracket (6) to the Backrest Frame (5) with two M10 x 70mm Bolts (26) and two M10 Locknuts (19). **Do not tighten the Locknuts yet.**

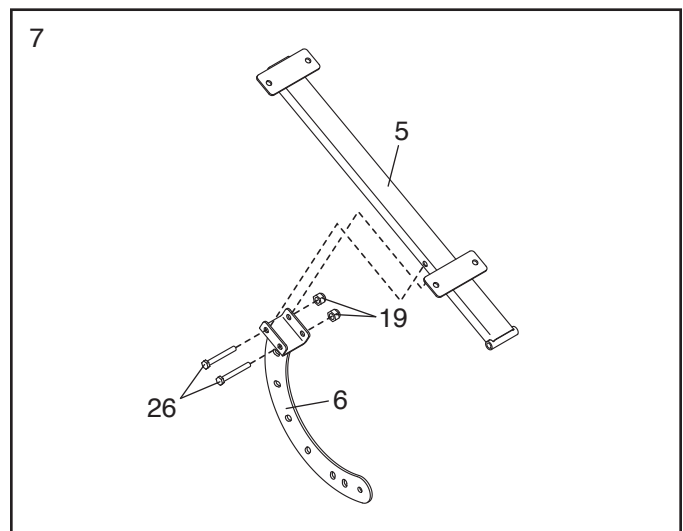

8. Apply some of the included grease to an M10 x 85mm Bolt (23).

Insert the Pivot Bracket (6) into the slot in the Frame (1). Attach the Backrest Frame (5) to the Frame with the M10 x 85mm Bolt (23) and an M10 Locknut (19). **Do not overtighten the Locknut; the Backrest Frame must pivot easily.**

Then, attach an M10 x 20mm Screw (25) and an M10 Locknut (19) to the hole in the end of the Pivot Bracket (6).

See step 7. Tighten the M10 Locknuts (19).

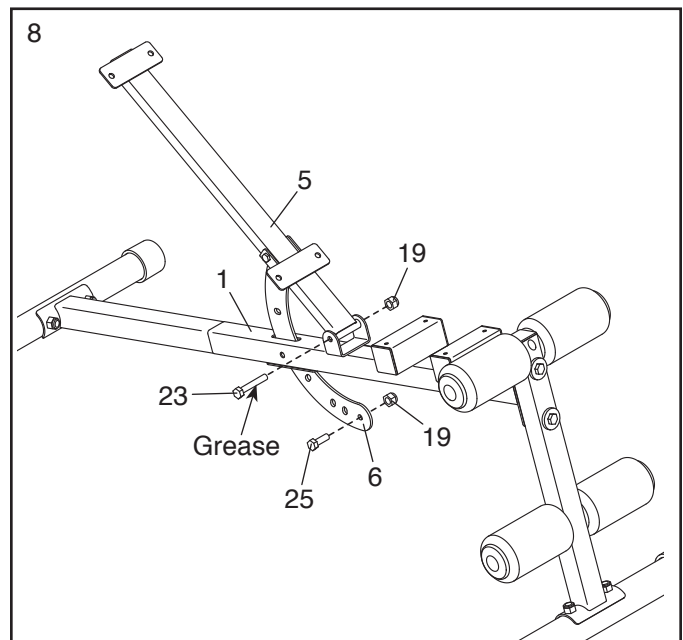

9. **See the inset drawing.** Attach the tether (A) on the Locking Pin (21) to the bottom of the Frame (1) with an M4 x 16mm Screw (28). Then, insert the Locking Pin into the Frame and into an adjustment hole in the Pivot Bracket (6).

Orient the Backrest (7) as shown. Attach the Backrest to the Backrest Frame (5) with four M6 x 16mm Screws (24); **start all the Screws, and then tighten them.**

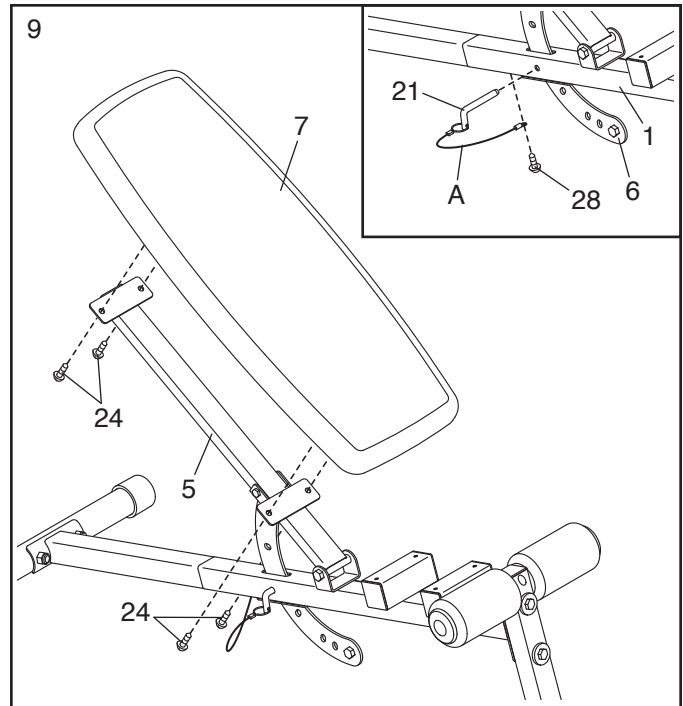

10. Attach the Seat (8) to the Frame (1) with four M6 x 60mm Screws (17) and four M6 Washers (22); **start all the Screws, and then tighten them.**

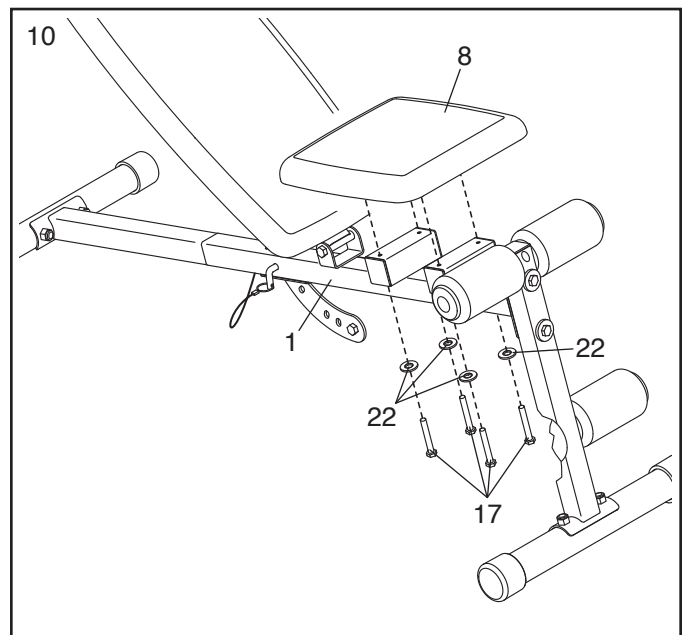

11. **Make sure that all parts are properly tightened before you use the weight bench.**

ADJUSTMENT

See the EXERCISE GUIDELINES on page 12 for important exercise information, and refer to the accompanying exercise guide to see the correct form for several exercises.

Make sure that all parts are properly tightened each time the weight bench is used. Replace any worn parts immediately. The weight bench can be cleaned with a damp cloth and a mild, non-abrasive detergent; **do not use solvents to clean the weight bench.**

ADJUSTING THE BACKREST

The Backrest (7) can be used in a declined position, a level position, or any of four inclined positions.

To adjust the Backrest (7), first remove the Locking Pin (21) from the Frame (1). Then, pivot the Backrest to the desired position, and reinsert the Locking Pin into the Frame and into an adjustment hole in the Pivot Bracket (6).

⚠ WARNING: Make sure that the Locking Pin (21) is fully inserted into the Frame (1) and into the Pivot Bracket (6).

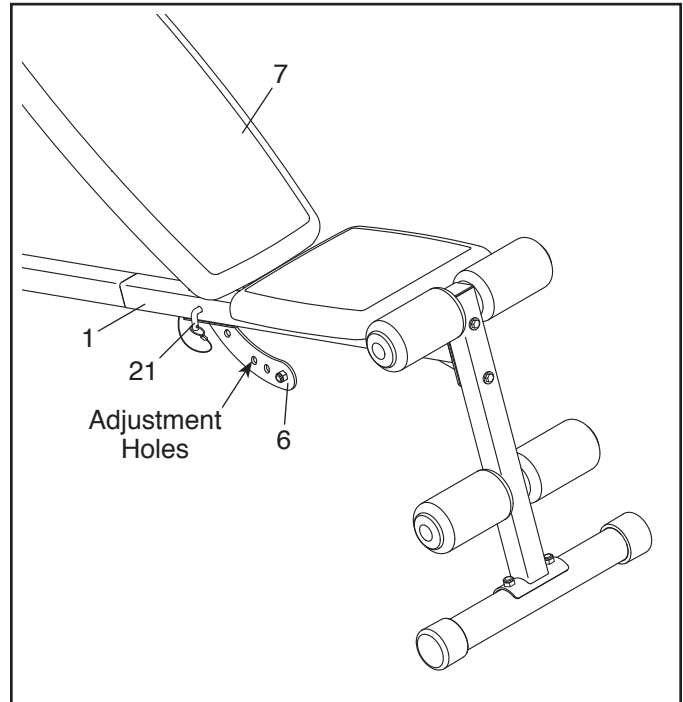

EXERCISE GUIDELINES

FOUR TYPES OF STRENGTH WORKOUTS

Note: A “repetition” is one complete cycle of an exercise, such as one sit-up. A “set” is a series of repetitions.

Muscle Building—Work your muscles near their maximum capacity and progressively increase the intensity of your exercise. Adjust the intensity level of an individual exercise as follows:

- Change the amount of resistance used.
- Change the number of repetitions or sets performed.

Use your own judgment to determine the amount of resistance that is right for you. Begin with 3 sets of 8 repetitions for each exercise you perform. Rest for 3 minutes after each set. When you can complete 3 sets of 12 repetitions without difficulty, increase the amount of resistance.

Toning—Tone your muscles by working them to a moderate percentage of their capacity. Select a moderate amount of resistance and increase the number of repetitions in each set. Complete as many sets of 15 to 20 repetitions as possible without discomfort. Rest for 1 minute after each set. Work your muscles by completing more sets rather than by using high amounts of resistance.

Weight Loss—To lose weight, use a low amount of resistance and increase the number of repetitions in each set. Exercise for 20 to 30 minutes, resting for a maximum of 30 seconds between sets.

Cross Training—Combine strength training and aerobic exercise by following this type of program:

- Strength training workouts on Monday, Wednesday, and Friday.
- 20 to 30 minutes of aerobic exercise on Tuesday and Thursday.
- One full day of rest each week to give your body time to regenerate.

WORKOUT GUIDELINES

Familiarize yourself with the equipment and learn the proper form for each exercise. Use your own judgment to determine the appropriate length of time for each

workout, and the numbers of repetitions and sets to complete. Progress at your own pace and be sensitive to your body’s signals. Follow each workout with at least one day of rest.

Warming Up—Start with 5 to 10 minutes of stretching and light exercise. A warm-up increases your body temperature, heart rate, and circulation in preparation for exercise.

Working Out—Include 6 to 10 different exercises in each workout. Select exercises for every major muscle group, emphasizing areas that you want to develop. To give balance and variety to your workouts, vary the exercises from workout to workout.

Cooling Down—Finish with 5 to 10 minutes of stretching. Stretching increases the flexibility of your muscles and helps to prevent post-exercise problems.

EXERCISE FORM

Move through the full range of motion for each exercise and move only the appropriate parts of the body. Perform the repetitions in each set smoothly and without pausing. The exertion stage of each repetition should last about half as long as the return stage. Exhale during the exertion stage of each repetition and inhale during the return stroke. Never hold your breath.

Rest for a short period of time after each set:

- Muscle Building—Rest for three minutes after each set.
- Toning—Rest for one minute after each set.
- Weight Loss—Rest for 30 seconds after each set.

STAYING MOTIVATED

For motivation, keep a record of each workout. Write the date, the exercises performed, the resistance used, and the numbers of sets and repetitions completed. Record your weight and key body measurements once a month. To achieve good results, make exercise a regular and enjoyable part of your life.

EXERCISE LOG

Make copies of this page, and use the copies to schedule and record your strength and aerobic workouts. Scheduling and recording your workouts will help you to make exercise a regular and enjoyable part of your life.

Strength

Date:

____ / ____ / ____

Exercise	Lbs.	Sets	Reps	Exercise	Lbs.	Sets	Reps
1.				6.			
2.				7.			
3.				8.			
4.				9.			
5.				10.			

Aerobic

Date:

____ / ____ / ____

Exercise	Time	Distance	Speed

Strength

Date:

____ / ____ / ____

Exercise	Lbs.	Sets	Reps	Exercise	Lbs.	Sets	Reps
1.				6.			
2.				7.			
3.				8.			
4.				9.			
5.				10.			

Aerobic

Date:

____ / ____ / ____

Exercise	Time	Distance	Speed

Strength

Date:

____ / ____ / ____

Exercise	Lbs.	Sets	Reps	Exercise	Lbs.	Sets	Reps
1.				6.			
2.				7.			
3.				8.			
4.				9.			
5.				10.			

Aerobic

Date:

____ / ____ / ____

Exercise	Time	Distance	Speed

PART LIST

Model No. GGBE4869.11 R0816A

Key No.	Qty.	Description	Key No.	Qty.	Description
1	1	Frame	17	4	M6 x 60mm Screw
2	1	Front Leg	18	4	M10 x 63mm Carriage Bolt
3	1	Rear Leg	19	10	M10 Locknut
4	1	Rear Stabilizer	20	2	M10 Washer
5	1	Backrest Frame	21	1	Locking Pin
6	1	Pivot Bracket	22	4	M6 Washer
7	1	Backrest	23	1	M10 x 85mm Bolt
8	1	Seat	24	4	M6 x 16mm Screw
9	4	Foam Pad	25	3	M10 x 20mm Screw
10	2	Pad Tube	26	2	M10 x 70mm Bolt
11	4	Pad Cap	27	2	M10 Large Washer
12	4	Stabilizer Cap	28	1	M4 x 16mm Screw
13	4	50mm Square Inner Cap	29	1	Front Stabilizer
14	1	45mm Square Inner Cap	*	–	User's Manual
15	1	25mm x 50mm Inner Cap	*	–	Exercise Guide
16	2	M10 x 63mm Bolt	*	–	Grease Packet

Note: Specifications are subject to change without notice. For information about ordering replacement parts, see the back cover of this manual. *These parts are not illustrated.

EXPLODED DRAWING

Model No. GGBE4869.11 R0816A

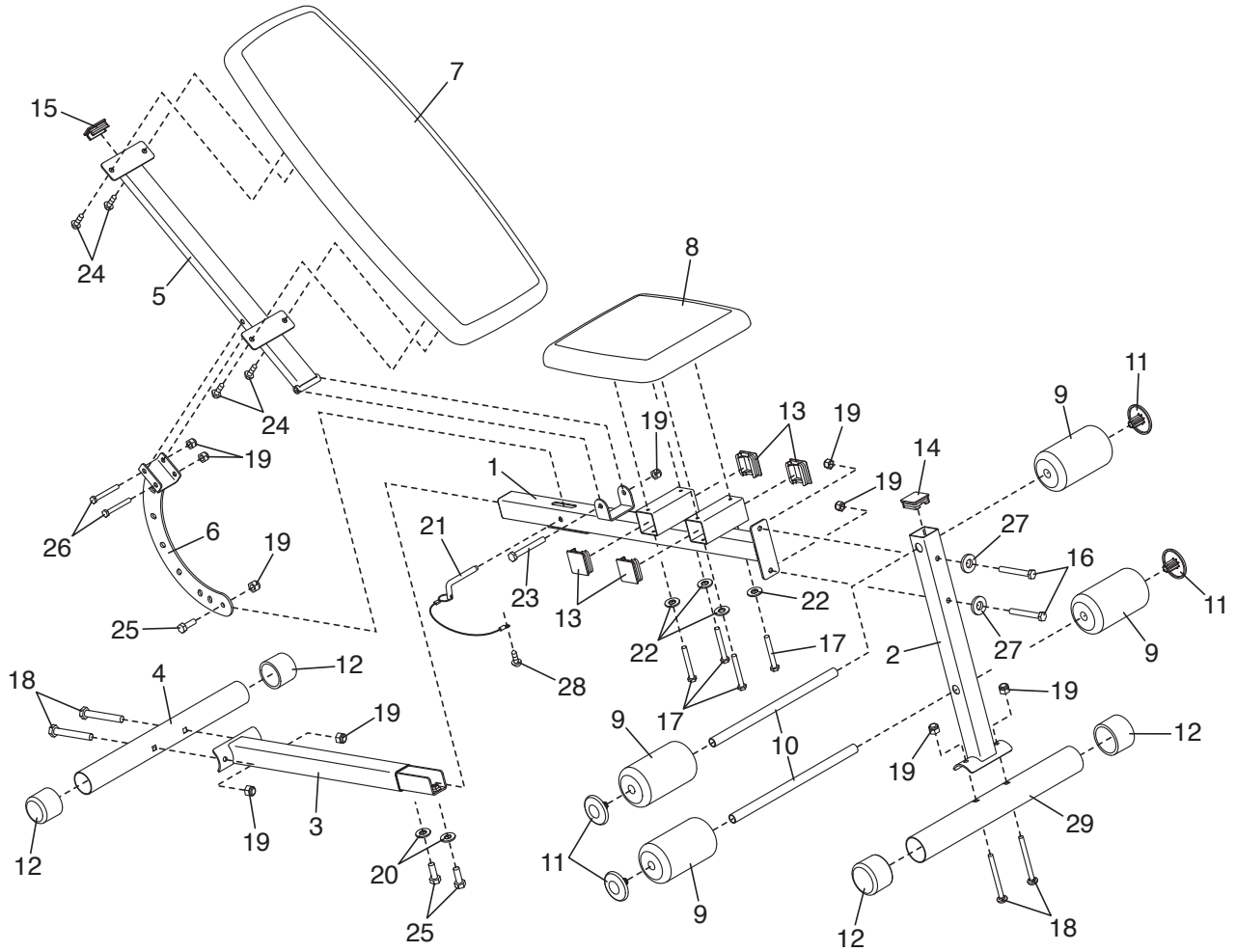

ORDERING REPLACEMENT PARTS

To order replacement parts, please see the front cover of this manual. To help us assist you, be prepared to provide the following information when contacting us:

- the model number and serial number of the product (see the front cover of this manual)
- the name of the product (see the front cover of this manual)
- the key number and description of the replacement part(s) (see the PART LIST and the EXPLODED DRAWING near the end of this manual)

LIMITED WARRANTY

IMPORTANT: To protect your fitness equipment with an extended service plan, see page 4.

ICON Health & Fitness, Inc. (ICON) warrants this product to be free from defects in workmanship and material, under normal use and service conditions. Parts and labor are warranted for ninety (90) days from the date of purchase.

This warranty extends only to the original purchaser (customer). ICON's obligation under this warranty is limited to repairing or replacing, at ICON's option, the product through one of its authorized service centers. All repairs for which warranty claims are made must be preauthorized by ICON. If the product is shipped to a service center, freight charges to and from the service center will be the customer's responsibility. If replacement parts are shipped while the product is under warranty, the customer will be responsible for a minimal handling charge. For in-home service, the customer will be responsible for a minimal trip charge. This warranty does not extend to freight damage to the product. This warranty will automatically be voided if the product is used as a store display model, if the product is purchased or transported outside the USA, if all instructions in this manual are not followed, if the product is abused or improperly or abnormally used, or if the product is used for commercial or rental purposes. No other warranty beyond that specifically set forth above is authorized by ICON.

ICON is not responsible or liable for indirect, special, or consequential damages arising out of or in connection with the use or performance of the product; damages with respect to any economic loss, loss of property, loss of revenues or profits, loss of enjoyment or use, or costs of removal or installation; or other consequential damages of any kind. Some states do not allow the exclusion or limitation of incidental or consequential damages. Accordingly, the above limitation may not apply to the customer.

The warranty extended hereunder is in lieu of any and all other warranties, and any implied warranties of merchantability or fitness for a particular purpose are limited in their scope and duration to the terms set forth herein. Some states do not allow limitations on how long an implied warranty lasts. Accordingly, the above limitation may not apply to the customer.

This warranty provides specific legal rights; the customer may have other rights that vary from state to state.

ICON Health & Fitness, Inc., 1500 S. 1000 W., Logan, UT 84321-9813

Free Manuals Download Website

<http://myh66.com>

<http://usermanuals.us>

<http://www.somanuals.com>

<http://www.4manuals.cc>

<http://www.manual-lib.com>

<http://www.404manual.com>

<http://www.luxmanual.com>

<http://aubethermostatmanual.com>

Golf course search by state

<http://golfingnear.com>

Email search by domain

<http://emailbydomain.com>

Auto manuals search

<http://auto.somanuals.com>

TV manuals search

<http://tv.somanuals.com>