

DIGITAL VIDEO SURVEILLANCE RECORDER

Instruction Manual

English Version 4.0

KEEP IN TOUCH

STAY CONNECTED



*8 Channel Model Shown



Thank you for purchasing the Edge Series Digital Video Surveillance Recorder.

This manual refers to the following models:

- LH338 (8-channel EDGE2)
- LH336 (16-channel EDGE2)
- LH348 (8-channel EDGE3)
- LH346 (16-channel EDGE3)

For the latest online manual, downloads and product updates, and to learn about our complete range of accessory products, please visit our website at:

www.lorextechology.com



CAUTION

**RISK OF ELECTRIC SHOCK
DO NOT OPEN**



CAUTION: TO REDUCE THE RISK OF ELECTRIC SHOCK DO NOT REMOVE COVER. NO USER SERVICABLE PARTS INSIDE.

REFER SERVICING TO QUALIFIED SERVICE PERSONNEL.



The lightning flash with arrowhead symbol, within an equilateral triangle, is intended to alert the user to the presence of uninsulated "dangerous voltage" within the products' enclosure that may be of sufficient magnitude to constitute a risk of electric shock.



The exclamation point within an equilateral triangle is intended to alert the user to the presence of important operating and maintenance (servicing) instructions in the literature accompanying the appliance.

WARNING: TO PREVENT FIRE OR SHOCK HAZARD, DO NOT EXPOSE THIS UNIT TO RAIN OR MOISTURE.

CAUTION: TO PREVENT ELECTRIC SHOCK, MATCH WIDE BLADE OF THE PLUG TO THE WIDE SLOT AND FULLY INSERT.



NEED HELP?

CONTACT US FIRST

DO NOT RETURN THIS PRODUCT TO THE STORE

Please make sure to register your product at www.lorextechnology.com to receive product updates and technical support.

2 Easy Ways to Contact Us



Online:

Product Support is available 24/7 including product information, user manuals, quick start up guides and FAQ's at www.lorextechnology.com/support

For all other matters, visit www.lorextechnology.com



By Phone:

North America:

Customer Service (for warranty matters): **1-888-425-6739** (1-888-42-LOREX)

Tech Support (for technical/installation issues): **1-877-755-6739** (1-877-75-LOREX)

Mexico: **001-800-681-9263, 001-800-514-6739**

International: **+800-425-6739-0** (Example: From the UK, dial 00 instead of +)



¿NECESITA AYUDA?

COMUNÍQUESE PRIMERO
CON NOSOTROS

BESOIN D'ASSISTANCE?

COMMUNIQUEZ D'ABORD
AVEC NOUS

NO DEVUELVA ESTE PRODUCTO A LA TIENDA

Por favor, registre su producto en www.lorextechnology.com para recibir actualizaciones del producto y asistencia técnica.

Hay 2 maneras fáciles de comunicarse con nosotros:

En línea:

Apoyo al cliente está disponible 24/7, incluyendo información del producto, manuales para el usuario, guías de inicio rápido y preguntas más frecuentes en:

www.lorextechnology.com/support

Para todo lo demás, visite

www.lorextechnology.com

Por teléfono:

Norte América:

Atención al cliente (para asuntos de la garantía):

1-888-425-6739 (1-888-42-LOREX)

Asistencia técnica (para asuntos técnicos o de instalación):

1-877-755-6739 (1-877-75-LOREX)

México: **001-800-681-9263, 001-800-514-6739**

Internacional: **+800-425-6739-0**

(Ejemplo: Desde el Reino Unido, marque el 00 en lugar del +)

NE RETOURNEZ PAS CE PRODUIT AU MAGASIN

Veuillez enregistrer votre produit sur le site www.lorextechnology.com afin de recevoir des mises à jour et le soutien technique pour votre produit.

2 façons simples de communiquer avec nous :

En ligne :

À votre disposition 24/7, le soutien pour les produits comprend les renseignements sur les produits, guides d'utilisation, guides de départ rapide et FAQ :

www.lorextechnology.com/support

Pour toutes les autres questions,

visitez www.lorextechnology.com

Par téléphone :

En Amérique du Nord :

Service à la clientèle (pour tout ce qui concerne la garantie) :

1-888-425-6739 (1-888-42-LOREX)

Soutien technique (pour les questions d'ordre technique ou relatives à

l'installation) : **1-877-755-6739** (1-877-75-LOREX)

México : **001-800-681-9263, 001-800-514-6739**

International : **+800-425-6739-0**

(par exemple : à partir du Royaume-Uni, composez le 00 au lieu de +)

BEFORE YOU START

Please make sure to register your product at www.lorextechnology.com to receive product updates and technical support

THIS PRODUCT MAY REQUIRE PROFESSIONAL INSTALLATION

LOREX IS COMMITTED TO FULFILLING YOUR SECURITY NEEDS



- We have developed user friendly products and documentation. Please read the Quick Start Guide and User Manual before you install this product.

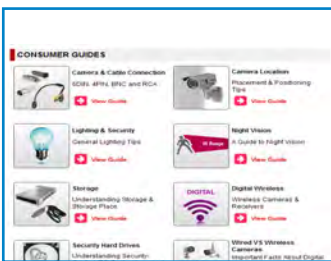

- Consumer Guides and Video Tutorials are available on our web site at www.lorextechnology.com/support



- If you require further installation assistance, please visit www.lorextechnology.com/installation or contact a professional installer.



- Please note that once the components of this product have been unsealed, you cannot return this product directly to the store without the original packaging.



AVANT DE COMMENCER

Veillez enregistrer votre produit sur le site www.lorextechnology.com afin de recevoir des mises à jour et le soutien technique pour votre produit.

CE PRODUIT PEUT NÉCESSITER UNE INSTALLATION PROFESSIONNELLE

LOREX S'ENGAGE À RÉPONDRE À VOS BESOINS EN MATIÈRE DE SÉCURITÉ

- Nous avons conçu et développé une documentation et des produits extrêmement conviviaux. Veillez lire le Guide de départ rapide et le Guide d'utilisation avant d'installer ce produit.
- Des guides pour consommateurs et des tutoriels vidéo vous sont offerts sur notre site Web : www.lorextechnology.com/support
- Si vous avez besoin de plus d'assistance pour l'installation de ce produit, veuillez visiter le site www.lorextechnology.com/installation ou communiquez avec un installateur professionnel.
- Veillez prendre note que lorsque vous avez déballé les pièces et composantes de ce produit, vous ne pouvez pas retourner celui-ci directement au magasin sans son emballage original.

ANTES DE EMPEZAR

Cerciórese de por favor colocar su producto en www.lorextechnology.com para recibir actualizaciones y la información del producto y soporte técnico.

ESTE PRODUCTO PUEDE EXIGIR UNA INSTALACIÓN PROFESIONAL

LOREX SE COMPROMETE A SATISFACER SUS NECESIDADES EN SEGURIDAD

- Favor de leer la guía de instalación rápida y la guía del usuario antes de instalar este product.
- Puede conseguir las guías del consumidor y los cursos en enseñanza video sobre el Internet visitando www.lorextechnology.com/support
- Si necesita ayuda para la instalación, visite www.lorextechnology.com/installation o contacte un especialista en instalaciones.
- Favor de notar que una vez que los componentes de este producto han sido removidos del embalaje, no podrá devolver este producto directamente a la tienda.



www.lorextechnology.com



VIEW YOUR WORLD™
VOIR VOTRE MONDE™
VEA SU MUNDO™

VANTAGE

Important Safeguards

In addition to the careful attention devoted to quality standards in the manufacture process of your product, safety is a major factor in the design of every instrument. However, safety is your responsibility too. This sheet lists important information that will help to ensure your enjoyment and proper use of the product and accessory equipment. Please read them carefully before operating and using your product.

General Precautions

1. All warnings and instructions in this manual should be followed.
2. Remove the plug from the outlet before cleaning. Do not use liquid aerosol detergents. Use a water-dampened cloth for cleaning.
3. Do not use this product in humid or wet places.
4. Keep enough space around the product for ventilation. Slots and openings in the storage cabinet should not be blocked.
5. It is highly recommended to connect the product to a surge protector to protect from damage caused by electrical surges. It is also recommended to connect the product to an uninterruptible power supply (UPS), which has an internal battery that will keep the product running in the event of a power outage.

Installation

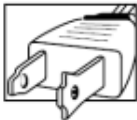
1. **Read and Follow Instructions** - All the safety and operating instructions should be read before the product is operated. Follow all operating instructions.
2. **Retain Instructions** - The safety and operating instructions should be retained for future reference.
3. **Heed Warnings** - Comply with all warnings on the product and in the operating instructions.
4. **Polarization** - Do not defeat the safety purpose of the polarized or grounding-type plug.

A polarized plug has two blades with one wider than the other.

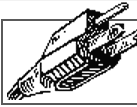

A grounding type plug has two blades and a third grounding prong.

The wide blade or the third prong are provided for your safety.

If the provided plug does not fit into your outlet, consult an electrician for replacement of the obsolete outlet.
5. **Power Sources** - This product should be operated only from the type of power source indicated on the marking label. If you are not sure of the type of power supplied to your location, consult your video dealer or local power company. For products intended to operate from battery power, or other sources, refer to the operating instructions.

6. **Overloading** - Do not overload wall outlets or extension cords as this can result in the risk of fire or electric shock. Overloaded AC outlets, extension cords, frayed power cords, damaged or cracked wire insulation, and broken plugs are dangerous. They may result in a shock or fire hazard. Periodically examine the cord, and if its appearance indicates damage or deteriorated insulation, have it replaced by your service technician.
7. **Power-Cord Protection** - Power supply cords should be routed so that they are not likely to be walked on or pinched by items placed upon or against them. Pay particular attention to cords at plugs, convenience receptacles, and the point where they exit from the product.
8. **Surge Protectors** - It is highly recommended that the product be connected to a surge protector. Doing so will protect the product from damage caused by power surges. Surge protectors should bear the UL listing mark or CSA certification mark.
9. **Uninterruptible Power Supplies (UPS)** - Because this product is designed for continuous, 24/7 operation, it is recommended that you connect the product to an uninterruptible power supply. An uninterruptible power supply has an internal battery that will keep the product running in the event of a power outage. Uninterruptible power supplies should bear the UL listing mark or CSA certification mark.

Caution: Maintain electrical safety. Power line operated equipment or accessories connected to this product should bear the UL listing mark or CSA certification mark on the accessory itself and should not be modified so as to defeat the safety features. This will help avoid any potential hazard from electrical shock or fire. If in doubt, contact qualified service personnel.

Installation (Continued)

10. **Ventilation** - Slots and openings in the case are provided for ventilation to ensure reliable operation of the product and to protect it from overheating. These openings must not be blocked or covered. The openings should never be blocked by placing the product on a bed, sofa, rug, or other similar surface. This product should never be placed near or over a radiator or heat register. This product should not be placed in a built-in installation such as a bookcase or rack unless proper ventilation is provided and the product manufacturer's instructions have been followed.
11. **Attachments** - Do not use attachments unless recommended by the product manufacturer as they may cause a hazard.
12. **Water and Moisture** - Do not use this product near water — for example, near a bath tub, wash bowl, kitchen sink or laundry tub, in a wet basement, near a swimming pool and the like.
13. **Heat** - The product should be situated away from heat sources such as radiators, heat registers, stoves, or other products (including amplifiers) that produce heat.
14. **Accessories** - Do not place this product on an unstable cart, stand, tripod, or table. The product may fall, causing serious damage to the product. Use this product only with a cart, stand, tripod, bracket, or table recommended by the manufacturer or sold with the product. Any mounting of the product should follow the manufacturer's instructions and use a mounting accessory recommended by the manufacturer.
15. **Camera Extension Cables** - Check the rating of your extension cable(s) to verify compliance with your local authority regulations prior to installation.
16. **Mounting** - The cameras provided with this system should be mounted only as instructed in this guide or the instructions that came with your cameras, using the provided mounting brackets.
17. **Camera Installation** - Cameras are not intended for submersion in water. Not all cameras can be installed outdoors. Check your camera environmental rating to confirm if they can be installed outdoors. When installing cameras outdoors, installation in a sheltered area is required.



Service

1. **Servicing** - Do not attempt to service this product yourself, as opening or removing covers may expose you to dangerous voltage or other hazards. Refer all servicing to qualified service personnel.
2. **Conditions Requiring Service** - Unplug this product from the wall outlet and refer servicing to qualified service personnel under the following conditions:
 - A. When the power supply cord or plug is damaged.
 - B. If liquid has been spilled or objects have fallen into the product.
 - C. If the product has been exposed to rain or water.
 - D. If the product has been dropped or the cabinet has been damaged.
 - E. If the product does not operate normally by following the operating instructions. Adjust only those controls that are covered by the operating instructions. Improper adjustment of other controls may result in damage and will often require extensive work by a qualified technician to restore the product to its normal operation.
 - F. When the product exhibits a distinct change in performance. This indicates a need for service.
7. **Replacement Parts** - When replacement parts are required, have the service technician verify that the replacements used have the same safety characteristics as the original parts. Use of replacements specified by the product manufacturer can prevent fire, electric shock, or other hazards.
8. **Safety Check** - Upon completion of any service or repairs to this product, ask the service technician to perform safety checks recommended by the manufacturer to determine that the product is in safe operating condition.

Use

1. **Cleaning** - Unplug the product from the wall outlet before cleaning. Do not use liquid cleaners or aerosol cleaners. Use a damp cloth for cleaning.
2. **Product and Cart Combination** - When product is installed on a cart, product and cart combination should be moved with care. Quick stops, excessive force, and uneven surfaces may cause the product and cart combination to overturn.
3. **Object and Liquid Entry** - Never push objects of any kind into this product through openings as they may touch dangerous voltage points or "short-out" parts that could result in a fire or electric shock. Never spill liquid of any kind on the product.
4. **Lightning** - For added protection of this product during a lightning storm, or when it is left unattended and unused for long periods of time, unplug it from the wall outlet and disconnect the antenna or cable system. This will prevent damage to the product due to lightning and power line surges.



WARNING: This product contains a button battery. If swallowed, it could cause severe injury or death in just two hours. Seek medical attention immediately.

NOTICES

FCC/IC Notice:

This equipment has been tested and found to comply with the limits for a Class B digital device, pursuant to Part 15 of the FCC Rules. These limits are designed to provide reasonable protection against harmful interference in a residential installation. This equipment generates, uses, and can radiate radio frequency energy and, if not installed and used in accordance with the instruction, may cause harmful interference to radio communications.

However, there is no guarantee that interference will not occur in a particular installation. If this equipment does cause harmful interference to radio or television reception (which can be determined by turning the equipment on and off), the user is encouraged to try to correct the interference by one or more of the following measures:

- Reorient or relocate the receiving antenna
- Increase the separation between the equipment and receiver
- Connect the equipment into an outlet on a circuit different from that to which the receiver is connected
- Consult the dealer or an experienced radio or television technician for assistance

Modification:

Any changes or modifications not expressly approved by the grantee of this device could void the user's authority to operate the device.

Toute modification non approuvée explicitement par le fournisseur de licence de l'appareil peut entraîner l'annulation du droit de l'utilisateur à utiliser l'appareil.

RoHS:



This product is fully compliant with the European Union Restriction of the Use of Certain Hazardous Substances in Electrical and Electronic Equipment ("RoHS") Directive (2002/95/EC). The RoHS directive prohibits the sale of electronic equipment containing certain hazardous substances such as lead, cadmium, mercury, and hexavalent chromium, PBB, and PBDE in the European Union.

This product has been certified and found to comply with the limits regulated by FCC, EMC, and LVD. Therefore, it is designated to provide reasonable protection against interference and will not cause interference with other appliance usage.

However, it is imperative that the user follows the guidelines in this manual to avoid improper usage, which may result in damage to the product, electrical shock and fire hazard injury.

In order to improve the features, functions, and quality of this product, the specifications are subject to change without notice from time to time.



- | | |
|--|---|
|  Product Information |  Specification Sheets |
|  User Manuals |  Software Upgrades |
|  Quick Start Guides |  Firmware Upgrades |

EDGE2 Series Features

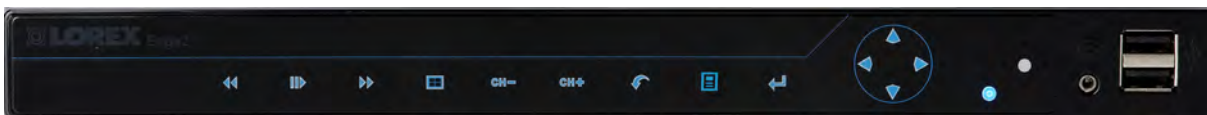

Digital Video Recorder Features

- HDMI output in full 1080p – simple connection to HDTVs¹
- Touch Screen navigation compatible²
- 24x7 100% duty cycle HDD
- Pentaplex operation - View, Record, Playback, Backup & Remotely control the system simultaneously
- Recording options: Motion, schedule, or continuous
- Small form factor (11.6 x 6.5 x 1.3")
- 3 x USB 2.0 ports (mouse, touch screen monitor, backup, firmware upgrade)
- VESA Mount (easily mounts to the back of an LCD monitor)³
- "Flex" IR extender for remote control (line-of-sight not required)
- Swipe-to-Switch dynamic allocation of camera location in live viewing
- Scroll-to-Search through recorded event list with image preview
- PTZ cameras supported (RS-485)

Connectivity Features⁴

- Instant Mobile Viewing on compatible Smartphones⁵
- Exclusive LOREX Easy Connect Internet Set-up Wizard
- Lorex Edge Client Software:
 - PC (Microsoft Windows™ 8 / 7 / Vista / XP compatible) using client software (included) and web browser
 - Mac remote client software (included)
- Free LOREX DDNS (Dynamic Domain Name Service) for advanced remote connectivity at all times
- Instant email alerts with snap shot attachments and web link

-
1. HDMI output 1080p (1920x1080) for high definition multi-channel live viewing only. High definition recording not supported. Recording resolution is limited to a maximum of 704x480 per channel. Image quality and resolution is dependent on the type of camera connected to the DVR.
 2. Touch operation with Windows™ 7 Touch compatible touch screen monitor via USB connection.
 3. Easily mounts to the back of an LCD monitor with VESA standard mounting holes and an independent stand. Requires clear access to the 100 x100 mm VESA mounting holes.
 4. Requires a high speed internet connection and a router (not included).
 5. Instant Mobile Viewing on iPad™, iPhone™, and BlackBerry (supported model numbers: 9000, 9700, 9800), Android (v. 2.1). Selectable one channel live viewing. Mobile phone data plan is required (not included). Router port forwarding required. For the latest smart phone compatibility list check www.lorextechnology.com as new smart phone models become available in the market.

EDGE3 Series Features

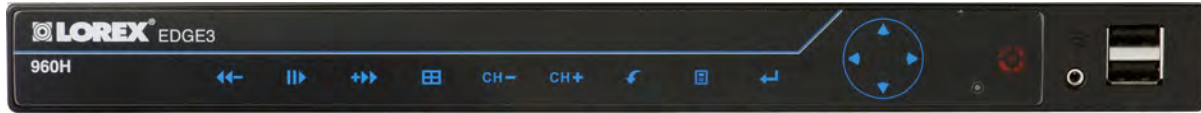

Digital Video Recorder Features

- 960H (960x480) recording resolution¹
- HDMI output in full 1080p – simple connection to HDTVs²
- Touch Screen navigation compatible³
- 24x7 100% duty cycle HDD
- Pentaplex operation - View, Record, Playback, Backup & Remotely control the system simultaneously
- Recording options: Motion, schedule, or continuous
- Small form factor (11.6 x 6.5 x 1.3")
- 3 x USB 2.0 (mouse, touch monitor, backup, firmware upgrade)
- VESA Mount (easily mounts to the back of an LCD monitor)
- "Flex" IR controller (line-of-sight not required)
- Mirror Hard Drive Recording⁴
- Expandable Hard Drive Storage
- PTZ cameras supported (RS485)

Connectivity Features⁵

- Advanced Management Software
- Instant Mobile Viewing on compatible Smartphones⁶
- Exclusive LOREX Easy Connect Internet Set-up Wizard
- PC (Microsoft Windows™ 8 / 7 / Vista / XP compatible) using Internet Explorer®
- Mac full function remote software
- Free LOREX DDNS (Dynamic Domain Name Service) for advanced remote connectivity at all times
- Instant e-mail alerts with snap shot attachments and web link

-
1. When used with 960H compatible cameras. DVR is backwards compatible and supports different camera inputs: standard resolution and 960H.
 2. HDMI output 1080p (1920x1080) for high definition multi-channel live viewing only. High definition recording not supported. Recording resolution is limited to a maximum of 960x480 per channel. Image quality and resolution is dependent on the type of camera connected to the DVR.
 3. Touch operation with Windows™ 7 compatible touch screen monitor via USB connection.
 4. Hard drive mirroring and External storage expansion are selectable options. You select one or the other, but not both at the same time. The DVR supports a single external USB hard drive up to a maximum size of 2TB. The external hard drive must be self-powered to work with the system; it cannot receive power from the DVR's USB port. Footage on the external hard drive can only be accessed using the DVR or a Windows PC. The footage cannot be accessed on a Mac.
 5. Requires a high speed internet connection and a router (not included).
 6. Instant Mobile Viewing on iPad®, iPhone®, BlackBerry (supported model numbers: 8900, 9000, 9700, 9800), Android (version 1.5 & above). Mobile phone data plan is required (not included). Router port forwarding required. For the latest smart phone compatibility list check www.lorextechnology.com as new smart phone models become available in the market.

TABLE OF CONTENTS

| | |
|---|-----------|
| Getting Started | 1 |
| Front Panel | 2 |
| Rear Panel (8-Channel) | 3 |
| Rear Panel (16-Channel) | 4 |
| Basic Setup | 5 |
| Step 1: Connect the BNC Cameras | 5 |
| Step 2: Connect the Monitor | 6 |
| Step 3: Connect the Mouse | 6 |
| Step 4: Connect the Ethernet Cable | 7 |
| Step 5: Connect the Flex IR Extender (Optional) | 7 |
| Step 6: Connect the Power Adapter | 7 |
| Step 7: Verify Camera Image | 8 |
| Step 8: Set the Time | 8 |
| Accessing System Information | 8 |
| Default System Passwords | 8 |
| Connecting Cameras | 9 |
| Installation Tips | 9 |
| Installing Cameras | 9 |
| Connecting BNC Cameras to your DVR | 10 |
| Connecting and Removing BNC Cables | 10 |
| Touch Screen Control | 11 |
| Mouse Control | 11 |
| Remote Control | 12 |
| Controls Quick Reference | 13 |
| On-screen Display | 14 |
| Using the On-Screen Keyboard | 16 |
| Using the Split-Screen Selector | 16 |
| Flexible Camera Assignment (Swipe-to-Switch) | 17 |
| Using Sequence View | 18 |
| Setting the Date and Time | 19 |
| Recording | 20 |
| Event Recording | 20 |
| Recording Audio | 20 |
| Event List | 21 |
| Channel Filter | 22 |
| Event Details | 22 |
| Searching for Recorded Data (Scroll-to-Search) | 22 |
| Playback | 24 |

| | |
|---|-----------|
| The Playback Bar, Playback Markers, and Smart Search Markers | 25 |
| Playback and Smart Search Markers | 25 |
| Taking Screenshots | 26 |
| Using Screenshots | 27 |
| Managing Passwords | 28 |
| User Accounts | 28 |
| Using the Password Wheel | 28 |
| Enabling and Disabling Passwords | 29 |
| Changing Passwords | 29 |
| Using the Main Menu | 30 |
| Camera | 31 |
| Configuring Camera Color Settings | 31 |
| Configuring the Covert Setting (Hidden Cameras) | 31 |
| Changing the Camera Title Display | 32 |
| Changing the Sequence Dwell Time | 32 |
| Changing the Camera Input Mode (EDGE3 Only) | 32 |
| Setup | 33 |
| Changing the Resolution and Video Output Mode | 33 |
| Accessing System Information | 33 |
| Changing the Fan Speed | 33 |
| Selecting PAL or NTSC | 33 |
| Changing the System Language | 33 |
| Adjusting HDMI Screen Size | 33 |
| Resetting the DVR to Factory Default Settings | 34 |
| Saving your System Configuration to a USB Flash Drive | 34 |
| Loading a System Configuration from a USB Drive | 34 |
| Record | 35 |
| Configuring Camera Frame Rate and Video Quality | 35 |
| Reading the Storage Calculator | 36 |
| Configuring the Recording Schedule | 36 |
| Viewing Hard Drive Information | 36 |
| Changing the Record Mode | 37 |
| Formatting Hard Drives | 37 |
| External Hard Drive Mirroring or Extension | 37 |
| Configuring your External Hard Drive for HDD Mirroring or Extension | 39 |
| Playing Back Video from the External Hard Drive | 39 |
| Alarm | 40 |
| Enabling / Disabling System Buzzers | 40 |
| Enabling / Disabling Motion Detection | 40 |
| Enabling / Disabling Video Loss Alarms | 40 |
| Configuring Alarm Settings | 40 |
| Configuring the Motion Alarm Schedule | 41 |
| Configuring the DVR for Motion Recording Only | 41 |
| Configuring Motion Detection Areas and Sensitivity | 42 |
| Backup | 43 |
| Formatting the USB Drive | 43 |

| | |
|---|-----------|
| Backing up Video to a USB Flash Drive | 44 |
| Confirming Backup | 44 |
| Backup File Information | 44 |
| Playing Backed-up Video on your Computer | 44 |
| Setting QuickTime Player as a Default Media Player (PC) | 45 |
| LAN | 46 |
| Changing the HTTP Port | 46 |
| Configuring Network Settings | 47 |
| Configuring Remote Access Passwords | 47 |
| Configuring Dual Streaming Settings | 48 |
| Configuring DDNS Settings | 48 |
| Configuring Email Alerts | 49 |
| Enabling/Disabling UPnP | 50 |
| Setting up your DVR for Remote Connectivity..... | 51 |
| System Requirements | 51 |
| Accessing your DVR Within a Local Network (LAN) | 51 |
| Step 1 of 4: Connect your DVR to the Local Area Network (LAN) | 51 |
| Step 2 of 4: Obtain the DVR's Local IP Address and HTTP Port | 52 |
| Step 3 of 4: Install the Client Software on your PC or Mac | 53 |
| Step 4 of 4: Configure the Client Software and Confirm Local Connection | 53 |
| Accessing your DVR Remotely Over the Internet | 55 |
| Step 1 of 4: Port Forwarding | 55 |
| Step 2 of 4: Create a DDNS Account | 55 |
| Step 3 of 4: Enable DDNS on the DVR | 59 |
| Step 4 of 4: Update the Client Software with your DDNS Information | 60 |
| Advanced Networking Configuration (Optional) | 61 |
| PC and Mac Client Software for Remote Viewing..... | 62 |
| Network User Accounts | 62 |
| Running the Client Software | 62 |
| Client Window | 63 |
| DVR List: Managing DVRs | 64 |
| Adding a DVR | 64 |
| Changing DVR Settings | 65 |
| Deleting a DVR | 65 |
| Live Viewing Mode | 66 |
| Playback Mode | 66 |
| Using the Pop-Up Calendar | 67 |
| Backup Mode | 67 |
| Setup Mode | 68 |
| Changing Bitrate Speed | 69 |
| Enabling PPPoE | 69 |
| Enabling DDNS | 69 |
| Viewing System Status | 70 |
| Configuring Email Alerts | 70 |
| Creating Custom Camera Titles | 71 |
| Taking Screenshots (PC Only) | 72 |

| | |
|---|------------|
| Manual Recording (PC Only) | 73 |
| Accessing Remote Speed Dome Settings (PTZ Controls) (PC Only) | 73 |
| Using the HDD Reader (PC Only) | 74 |
| DVR Netviewer: Viewing Your DVR Using a Web Browser | 76 |
| Connecting to your DVR Using a DDNS or IP Address | 76 |
| Connecting to the DVR over a LAN Using UPnP | 77 |
| Internet Explorer | 78 |
| Internet Explorer 9 / 10 | 79 |
| Mozilla Firefox | 80 |
| Google Chrome | 82 |
| Mobile Apps: Accessing your DVR Using a Mobile Device | 85 |
| Compatible Devices and Platforms | 85 |
| Before You Begin | 85 |
| iPhone / iPad App | 86 |
| Downloading the Lorex Live Application on iPhone / iPad | 86 |
| Connecting To Your DVR on the iPhone | 86 |
| The Lorex Live Interface | 87 |
| Connecting To Your DVR on the iPad | 88 |
| Using the Address Book on the iPhone / iPad | 90 |
| Accessing Backed up Video on the iPad | 91 |
| Android App | 92 |
| Connecting to your DVR on Android | 92 |
| Lorex Mobile Edge Viewing Interface | 93 |
| Setup Menu | 93 |
| Playback Mode | 94 |
| PTZ Controls | 95 |
| Address Book | 96 |
| Blackberry App | 97 |
| Installing Mobile View on the Blackberry: | 97 |
| Connecting to your DVR on your Blackberry | 98 |
| Viewing Your DVR on your Blackberry | 99 |
| Enabling APN (Access Point Name) on Your Blackberry | 100 |
| Appendix A: System Specifications | 102 |
| EDGE2 Series | 102 |
| EDGE3 Series | 103 |
| Appendix B: Assigning a Fixed IP to your DVR | 104 |
| What's the difference between DHCP and Fixed IPs? | 104 |
| Setting up a Fixed IP Address | 105 |
| Appendix C: Connecting PTZ Cameras | 108 |
| Controlling PTZ Cameras | 109 |
| Using PTZ Presets | 109 |
| Appendix D: Recording and Playing Audio | 111 |

| | |
|---|------------|
| Connecting an Audio-Capable Camera or Self-Powered Microphone | 111 |
| Playing Audio from your DVR | 112 |
| Appendix E: Mounting the DVR to a VESA Mount | 113 |
| Appendix F: Replacing the Hard Drive | 114 |
| Removing the Hard Drive | 114 |
| Replacing the Hard Drive | 116 |
| Formatting the Hard Drive | 117 |
| Appendix G: Upgrading Firmware | 118 |
| If you do not see Buttons in DVR Netviewer After Upgrading the Firmware... .. | 119 |
| Troubleshooting | 121 |
| Troubleshooting Remote Connections | 124 |

Getting Started

The system comes with the following components:



DVR (DIGITAL VIDEO RECORDER)*



12V DC POWER ADAPTER



REMOTE CONTROL



USB MOUSE



ETHERNET CABLE



MOUNTING KIT
(Mounting Kit contents may differ from image)



FLEX IR EXTENDER



2 X OCTOPUS BNC CONNECTOR
(16-channel only)



**QUICK START GUIDE
INSTRUCTION MANUAL
DOCUMENTATION CD**

*HARD DRIVE SIZE, NUMBER OF CHANNELS, AND CAMERA CONFIGURATION MAY VARY BY MODEL. PLEASE REFER TO YOUR PACKAGE FOR SPECIFIC DETAILS. CHECK YOUR PACKAGE TO CONFIRM THAT YOU HAVE RECEIVED THE COMPLETE SYSTEM, INCLUDING ALL COMPONENTS SHOWN ABOVE.

Front Panel

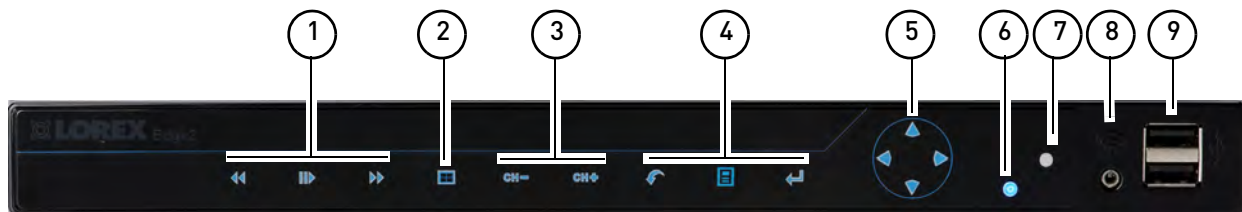

1 Playback Controls:

- **◀◀**: In Playback mode, press to rewind video. Press repeatedly to increase rewind speed.
 - While playback is paused, press to move back playback time or date.
 - In menus, press to change settings.
- **⏮**: In Viewing mode, press to enter Playback mode.
 - In Playback mode, press to play video. Press again to pause video playback.
- **▶▶**: In Playback mode, press to fast forward video. Press repeatedly to increase fast forward speed.
 - While playback is paused, press to advance playback time or date.
 - In menus, press to change settings.

2 Quad/Split-screen View:

- **⏏**: Press to open the Split-Screen Selector. From Full Screen / Single-Channel view, press to switch to Split-Screen view.

3 Channel Selection:

- **CH-**: Press to select previous channel.
 - While in Split-Screen view, press to open previously selected channel in full-screen view.
- **CH+**: Press to select next channel.
 - While in Split-Screen view, press to open previously selected channel in full-screen view.

4 Menu Controls:

- **↶**: Press to go back / exit menus.
 - In Playback mode, press to return to Viewing mode.
 - In Full Screen / Single-Channel mode, press to return to Split-screen view.
- **☰**: Press to enter Main Menu.
- **⏏**: Press to confirm menu selections.
 - In Viewing mode, press to access System Information.
 - In Playback mode, press to create a Playback Marker.

5 Navigation Buttons:

- ▲: Press to move cursor up.
- ▼: Press to move cursor down.
- ◀: Press to move cursor left.
- ▶: Press to move cursor right.

6 Hard Drive / Power LED:

- **Solid:** Device is on / powering up.
- **Flashing:** Device is recording to hard drive.

7 IR Receiver: Internal IR receiver for the remote control.

8 Flex IR Extender Port: Connect the Flex IR Extender to increase the remote control range or use the remote control without needing line of sight to the DVR (must have line of sight to Flex IR Extender).

9 USB Ports: Connect a USB mouse (included), touch screen monitor (not included), or a USB flash drive (not included) for data backup and firmware updates.

Rear Panel (8-Channel)

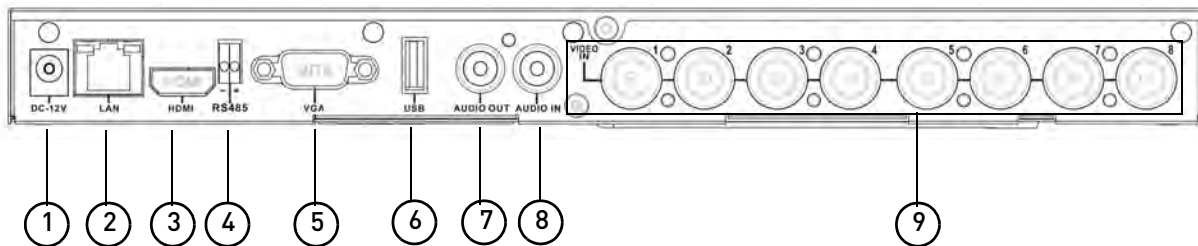

1 DC 12V: Connect the included DC power adapter to power on the DVR.

2 LAN: Connect a CAT 5 RJ45 Ethernet cable for local and remote connectivity.

3 HDMI: Connect to an HDMI-compatible TV or monitor (not included). Note that the DVR cannot use a VGA and HDMI monitor at the same time.

4 RS485: Connect RS485 cables for compatible PTZ cameras (not included).

5 VGA: Connect to a VGA monitor (not included). Note that the DVR cannot use a VGA and HDMI monitor at the same time.

6 USB: Connect to a Windows 7® Touch compatible touch screen monitor (not included), mouse (included), USB flash drive (not included) for data backup and firmware updates), or self-powered external hard drive (not included) for disk mirroring (PC required) or expansion.

NOTE: The DVR supports a single external hard drive up to a maximum size of 2TB. The external hard drive must be self-powered to work with the system; it cannot receive power from the DVR's USB port.

7 Audio Out: Output for audio channel.

8 Audio In: Input for audio channel.

9 BNC Video In: Connect up to 8 BNC cameras.

Rear Panel (16-Channel)

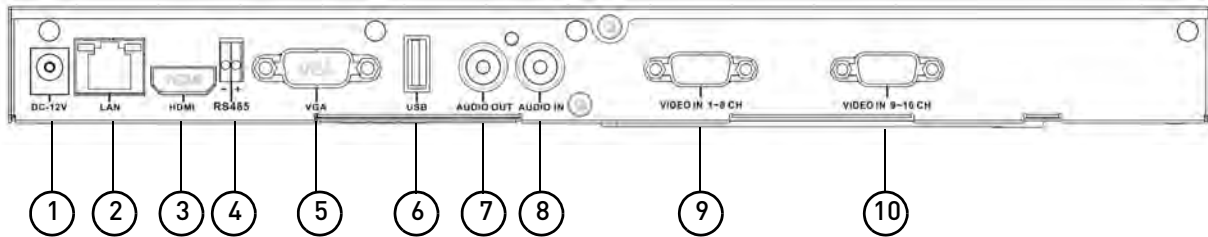

- 1 DC 12V:** Connect the included DC power adapter to power on the DVR.
- 2 LAN:** Connect a CAT 5 RJ45 Ethernet cable for local and remote connectivity.
- 3 HDMI:** Connect to an HDMI-compatible TV or monitor (not included). Note that the DVR cannot use a VGA and HDMI monitor at the same time.
- 4 RS485:** Connect RS485 cables for compatible PTZ cameras (not included).
- 5 VGA:** Connect to a VGA monitor (not included). Note that the DVR cannot use a VGA and HDMI monitor at the same time.
- 6 USB:** Connect a USB mouse (included), touch screen monitor (not included), USB flash drive (not included) for data backup and firmware updates, or self-powered external hard drive (not included) for disk mirroring (PC required) or expansion.
NOTE: The DVR supports a single external hard drive up to a maximum size of 2TB. The external hard drive must be self-powered to work with the system; it cannot receive power from the DVR's USB port.
- 7 Audio Out:** Output for audio channel.
- 8 Audio In:** Input for audio channel.
- 9 Video IN 1~8CH:** Connect Octopus BNC connector here. Connect BNC connectors from cameras 1-8 to Octopus BNC connector.
- 10 Video IN 9~16CH:** Connect Octopus BNC connector here. Connect BNC connectors from cameras 9-16 to Octopus BNC connector.

Basic Setup

NOTE: This DVR features unique mounting options and can be mounted to back of LCD monitors with a VESA mount. For mounting instructions, see "Appendix E: Mounting the DVR to a VESA Mount" on page 113. If you intend to mount the DVR, it is recommended to do so before completing setup.

Step 1: Connect the BNC Cameras

8-channel

- Connect the BNC cameras to the **Video IN** ports on the rear panel of the DVR.



Push and twist the BNC connector clockwise to secure it to the BNC port.

16-channel

- 1 Connect the Octopus BNC connector for channels 1-8 (included) to the **Video IN CH 1~8** port on the rear panel of the DVR. Connect the Octopus BNC connector for channels 9-16 (included) to the **Video IN CH9~16** port. The label at the end of each connector indicates the channel number.
- 2 Connect the BNC cameras to the Octopus BNC connector(s).



Connect this end to Video In port on your DVR

NOTE: Do not connect to VGA port



Push and twist the BNC connector clockwise to secure it to the Octopus BNC connector

Labels indicate channel number

NOTE: For more information on installing cameras, see "Connecting Cameras" on page 9.

Step 2: Connect the Monitor

NOTE: Lorex monitors and touch screen monitors include all the necessary cables and adapters to connect to your DVR. Check your monitor documentation to see which cables and adapters are included with your monitor.

- 1 If you are using a touch screen monitor, connect a USB cable (not included) from the monitor to the **USB** port on the rear panel of the DVR.
- 2 Connect a HDMI cable (not included) from the monitor to the **HDMI** port (recommended) **OR**;
 - Connect a VGA cable (not included) from the monitor to the **VGA** port.
- 3 Power on the monitor.

NOTE: If you have a monitor with a DVI input, you must use an HDMI to DVI adapter (not included). You cannot use a DVI to VGA adapter.

8-channel model shown

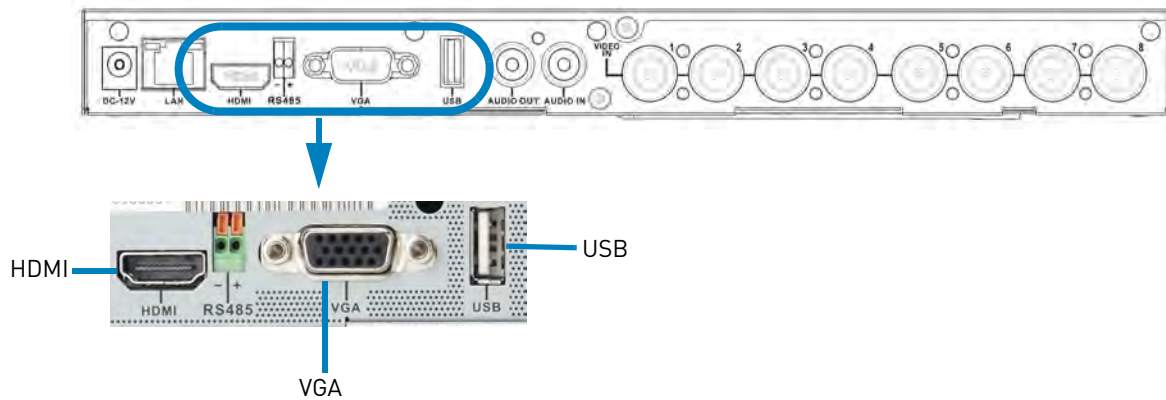

NOTE: The DVR cannot use multiple monitors at the same time.

Step 3: Connect the Mouse

- Connect a USB mouse to one of the **USB** ports on the front or rear panel of the DVR.

8-channel model shown

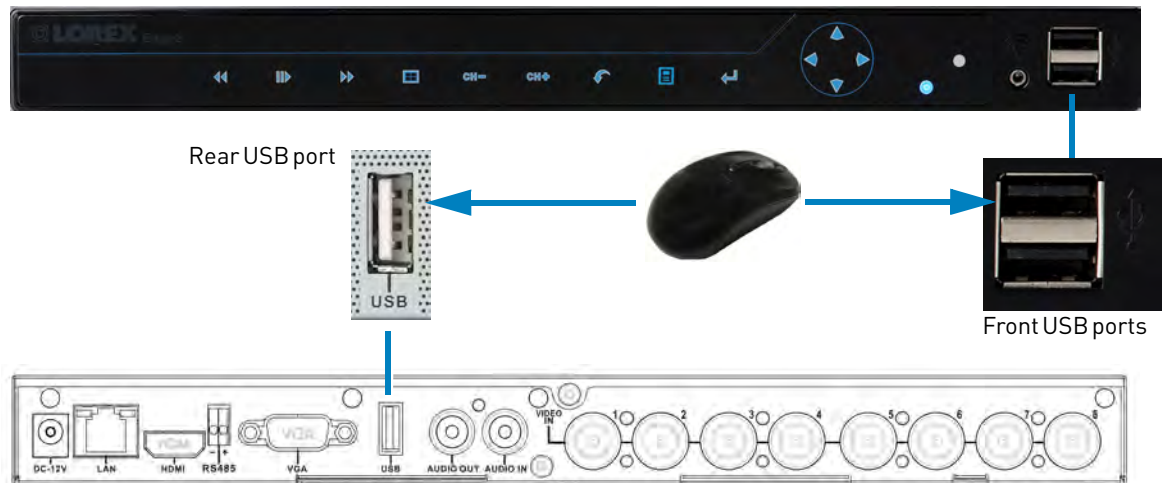

Step 4: Connect the Ethernet Cable

- Connect the Ethernet cable to the **LAN** port on the rear panel of the DVR. Connect the other end of the Ethernet cable to a router on your network.

8-channel model shown

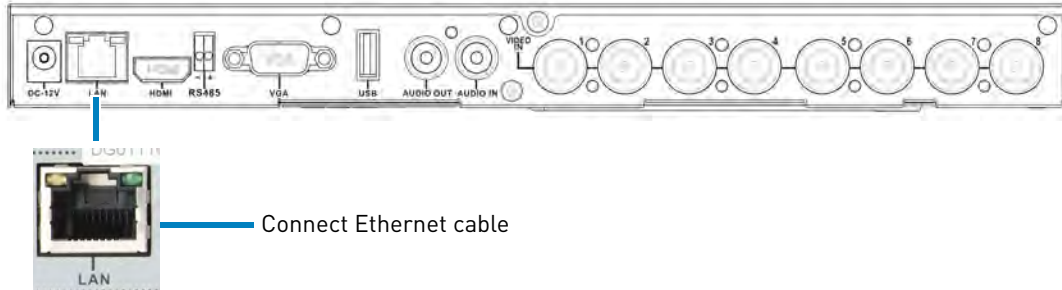

Step 5: Connect the Flex IR Extender (Optional)

- Connect the Flex IR Extender to the **Flex IR Extender** port on the front panel of the DVR. Position the Flex IR Extender near the front of the monitor or where it will receive a clear signal from the remote control.

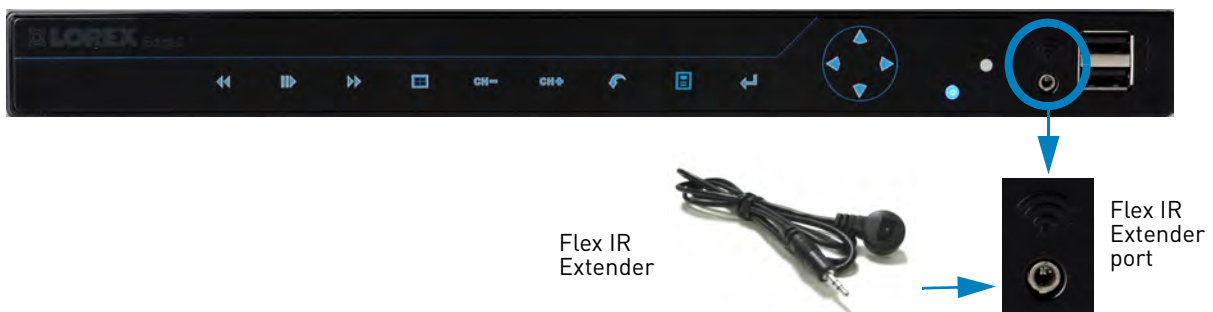

NOTE: The Flex IR Extender is not required to use the DVR. Use the Flex IR Extender to install the DVR where it will not have line of sight to the remote control, such as in a cabinet or behind the monitor.

Step 6: Connect the Power Adapter

- Before powering up the DVR, ensure the monitor is connected and powered on. This allows the DVR to detect the best resolution for your monitor.
- Connect the power adapter to the **DC 12V** port on the rear panel of the system. Connect the other end of the power adapter to a power outlet or surge protector.

8-channel model shown

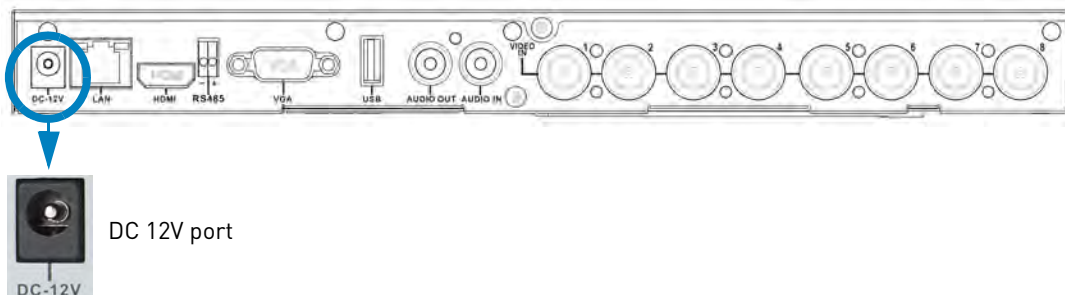

NOTE: If the top or bottom of the screen is cut off on your HDTV, see “Adjusting HDMI Screen Size” on page 33 to adjust the screen size.



Step 7: Verify Camera Image

- Power on the cameras, and then verify the camera video quality before permanently mounting the cameras.
- Mount the cameras under a sheltered location. Always verify the environmental rating of your cameras before permanent installation outdoors.

Step 8: Set the Time

- Set the system time for accurate video timestamps. Videos with inaccurate times may not be valid as surveillance evidence.
- For details on setting the system time, see “Setting the Date and Time” on page 19.

Accessing System Information

- To quickly open a window that displays vital system information, press the  button on the front panel of the DVR. Press  to exit the System Information window.



Default System Passwords

- The DVR requires a user name (ID) and password to log in **remotely** using a computer or mobile device.
- The HTTP port (default **80**) must be port forwarded on your router to access the DVR over the Internet or a local network.

Refer to the following tables for the default account user names and passwords for the DVR.

Local DVR Access:

| Level | User ID | Password |
|-------|---------|----------|
| USER1 | 1 | 1111 |
| USER2 | 2 | 2222 |
| ADMIN | 3 | 3333 |

Remote/LAN Access:

| Level | User ID | Password |
|-------|---------|----------|
| USER1 | 7 | 1111 |
| USER2 | 8 | 2222 |
| ADMIN | 9 | 3333 |

Connecting Cameras

ATTENTION: Cameras differ in terms of installation or mounting instructions. Please see the documentation that came with your camera(s) for specific installation instructions.

Test the cameras before permanent installation. Plan where you will route the wiring for the camera and where you will aim the camera.

Installation Tips

- Mount the camera where the lens is away from direct and intense sunlight.
- Plan your cable wiring so that it does not interfere with power lines or telephone lines.
- Ensure that the camera wiring is not exposed or easily cut.
- Mount the camera in an area that is visible, but out of reach.
- Avoid pointing the camera at a glass window to see outside, as this may result in a poor image caused by glare from indoor / outdoor lighting conditions.
- Adjust the camera angle so that it covers an area with high traffic.
- In "high-risk" locations, have multiple cameras point in the same area. This provides camera redundancy if a vandal attempts to damage the camera.

Installing Cameras

- 1 Mount the camera(s) to the desired mounting surface according to the instructions that came with the camera(s). Choose a firm mounting surface.

NOTE: If you wish to mount cameras to drywall, it is recommended to use drywall plugs (not included).

- 2 Adjust the camera stand to ensure that the camera has a satisfactory view of the area you would like to monitor. Stand configuration depends on the mounting surface you have chosen (see below for suggested stand configurations).



Table Mount



Wall Mount



Ceiling Mount

Camera model not be exactly as shown.

NOTE: There are two connection points for certain cameras. Secure the stand to the top thread for wall mounts or ceiling mounts. Secure the stand to the bottom thread for table mounts or wall mounts.

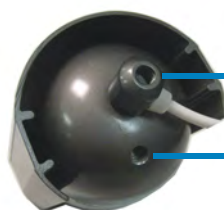

Top thread
(Ceiling mount, Wall mount)

Bottom thread
(Table mount)



Secure to camera
thread

Camera model may not be exactly as shown.

Connecting BNC Cameras to your DVR

- 1 Connect the male power connector on the BNC extension cable to the female power connector on the camera.
 - Connect the BNC connector to the camera.
- 2 Connect the female power connector on the BNC extension cable to the power adapter.
- 3 [8-channel] Connect the BNC connector to one of the **Video In** ports on the rear panel of the DVR.
 - [16-channel] Connect the Octopus BNC connector for channels 1-8 (included) to the **Video IN CH 1~8** port and the Octopus BNC connector for channels 9-16 (included) to the **Video IN CH9~16** port on the rear panel of the DVR. Connect the BNC cameras to the Octopus BNC connector(s). The label at the end of each connector indicates the channel number.
- 4 Plug the power adapter to a power outlet.

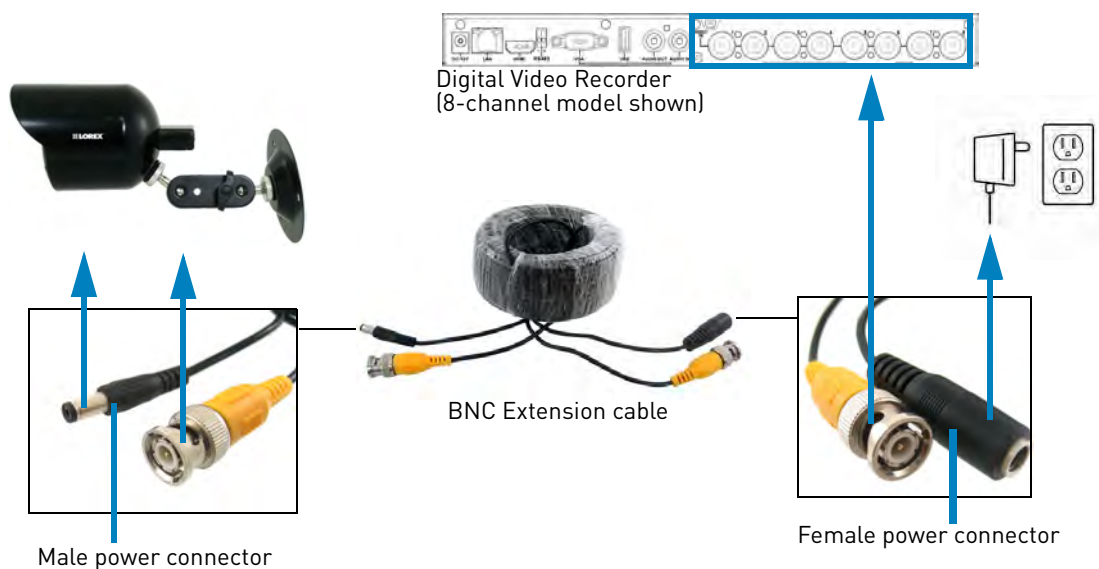

Connecting and Removing BNC Cables

BNC (Bayonet Nut Connector) is a special connector that locks on to the system port and cannot be accidentally removed.

To connect or remove a BNC connector:

- Push the BNC connector firmly into the BNC port and simultaneously twist the connector clockwise to tighten.
- To remove a BNC connector from a BNC port, push and simultaneously twist the connector counter-clockwise to loosen the BNC connector.

Touch Screen Control



This DVR features unique touch screen navigation capabilities. It supports Windows 7® Touch compatible touch screen monitors without needing any additional configuration.

To connect a touch screen monitor:

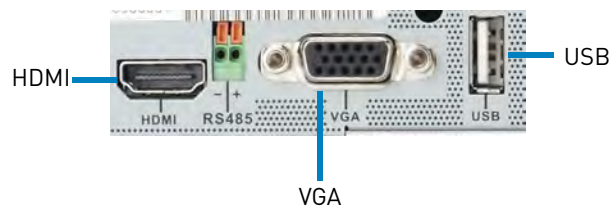
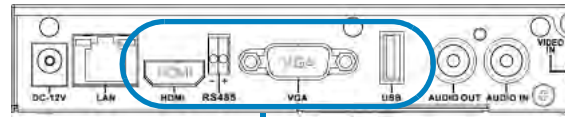
- 1 Connect the VGA or HDMI cable (not included) from the monitor to the **VGA** or **HDMI** port on the rear panel of the DVR.
- 2 Connect a USB cable (not included) from the monitor to the **USB** port on the rear panel of the DVR.



To navigate the DVR using touch screen controls:

- Touch the icons on the display to access / navigate the menus.
- Touch  to go back / exit menus.
- Change menu settings by swiping your finger up and down.
- In Split-Screen mode, Touch a camera to view that camera in full-screen. Touch  to return to Split-Screen mode.
- **Swipe-to-Switch:** In Viewing or Playback mode, you can switch cameras by swiping your finger left or right. Release your finger when the desired camera is highlighted to select it.



NOTE: In Split-Screen view, this changes the order of your cameras.

Mouse Control

The DVR can be controlled using a USB mouse.

To use a mouse with the DVR:

- Connect the mouse to one of the **USB** ports on the front or rear panels of the DVR.

Use the mouse buttons to perform the following:

- 1 **Left-Button:** Click to select a menu option. While in Split-Screen mode (Viewing or Playback), click on a camera to view the selected channel in full-screen.
- 2 **Right-Button:** Click to go back / exit menus.
- 3 **Scroll-Wheel:** Scroll up / down to change values in selected menu options or select Playback Markers in Playback Bar.

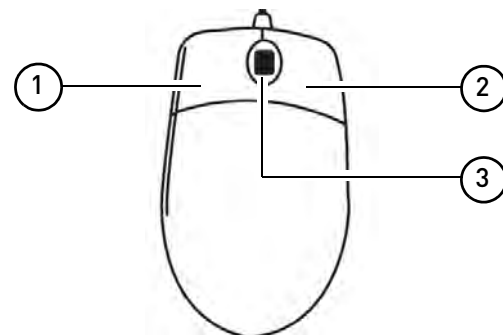

Remote Control





The DVR can also be controlled using the included remote control.

To use the remote control:

1 **LIST**: Open the Event List.

2 **MENU**: Opens the DVR Main Menu.

3 Primary Controls:



- : Confirm menu selections; in Playback mode, create Playback Marker; in Viewing mode, view system information.
- : Move cursor in menus left; in Playback, increase rewind speed.
- : Move cursor in menus right; in Playback, increase fast-forward speed.
- : Move cursor in menus up; channel up.
- : Move cursor in menus down; channel down.

4 **ESC**: Go back / exit menus.

5 : While in Event List, press to delete the selected event.

NOTE: Be careful when pressing the Trash button—there is no confirmation for deletion and you cannot undo the action.

6 Increase / Decrease Buttons:

- : Increase the value of selected menu option.
- : Decrease the value of selected menu option.

7 **OSD**: Show / hide the On-screen Display.

8 : Enter Split-Screen mode; Open the Split-Screen Selector.





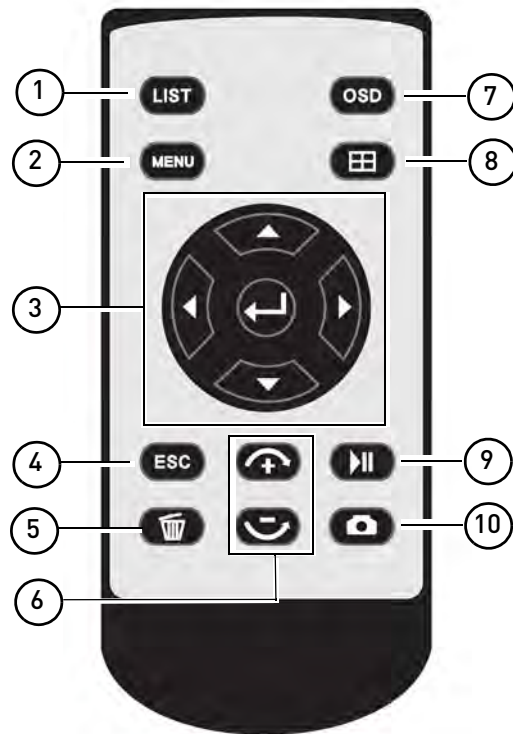





9 : Enter Playback mode; Play / pause playback; In Event List, select event for playback.

10 : During Viewing and Playback, press to take a screenshot of the main display—USB flash drive must be connected.



Controls Quick Reference

The following chart shows how to navigate the menus using the various control options available on the DVR.

| Using: | Select Option: | Change Setting: | Go Back / Exit Menu: | Move Cursor |
|-----------------|---|---|--|---|
| Mouse | Left-click | Scroll wheel up / down | Right-click | N/A |
| Touch Screen | Tap | Swipe up / down or left / right |  | N/A |
| Remote Control |  |  /  |  |  |
| DVR Front Panel |  |  /  |  |  |

On-screen Display

ATTENTION: The instructions in this manual describe how to operate the DVR using a mouse (included). When using a touch screen monitor (not included), simply touch the on-screen buttons when told to click, swipe your finger horizontally or vertically to scroll up / down, and touch  to right-click and exit menus. All the features of this DVR can be accessed using a touch screen monitor.

16-channel model shown

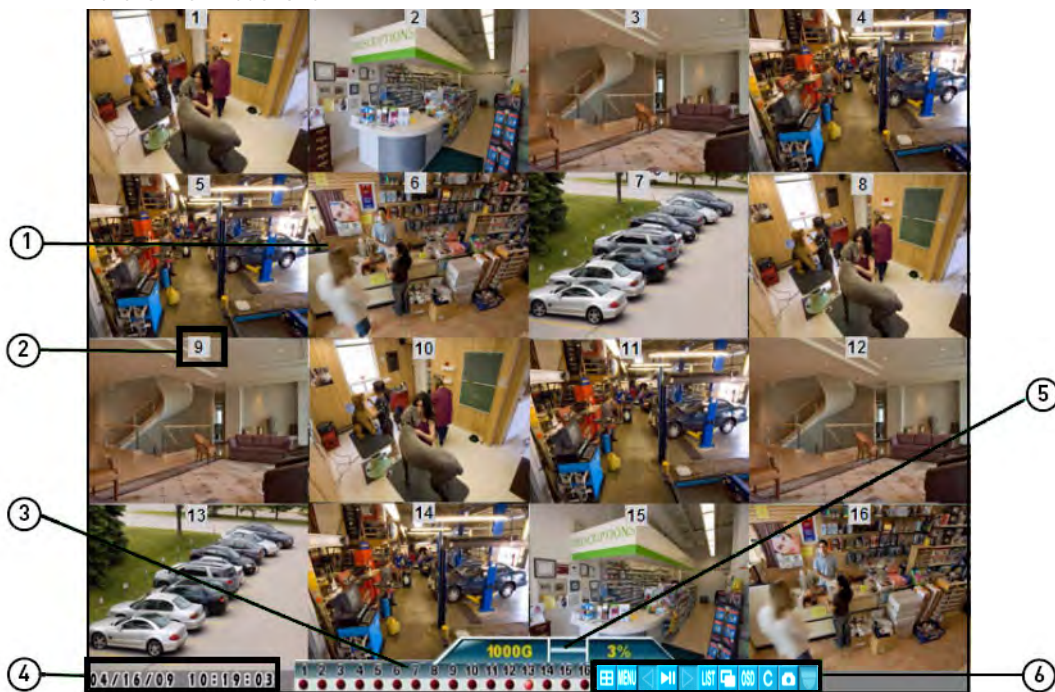

- 1 **Display Screen:** Shows live and recorded video in Full-screen / Single-Channel mode and Split-Screen (16-way split on 16-channel model only) view.
- 2 **Camera Number / Title:** You can set the DVR to show the camera number, title, or no title.
- 3 **Channels:** Displays channels on the DVR. Icons flash red to indicate recording is in progress.
- 4 **Date / Time:** Displays the date and time on the DVR.
- 5 **HDD Status:** Displays the size of the pre-installed hard drive (for example, 1000GB) and the recording space consumed on the hard disk (%).













Total size of hard drive   Percent full

NOTE: This reading is an approximation.

- 6 **Toolbar:** Move the mouse to the bottom of the screen to view the toolbar. Click these buttons to access the menus and control the DVR.



NOTE: Additional buttons are shown in some screens.

- : Click to open the Split-Screen Selector; In Full Screen / Single Channel mode, click to open Split-screen view.
- : Click to open the Main Menu. See “Using the Main Menu” on page 30.
- : Click to move cursor left in menus.
- : Click to move cursor right in menus.
- : From Viewing mode, click to open Playback mode. Click to play / pause video.
- : Click to rewind / increase rewind speed (only available during playback).
- : Click to fast forward / increase fast forward speed (only available during playback).
- : Click to open the Event List. See “Event List” on page 21.
- : Click to begin Sequence view. In Sequence view, the DVR automatically switches between connected cameras in Full Screen / Single Channel view. Click  to exit Sequence view.
- : Click to turn the On-Screen Display on / off.
- : Click to go back / exit menus.
- : Click to take a screenshot of the active display (live viewing or playback).

NOTE: USB flash drive (not included) must be connected. For more details, see “Taking Screenshots” on page 26.
- : From the Event List, click to delete a selected video file.

NOTE: Be careful when clicking the Trash icon—there is no confirmation for deletion and you cannot undo the action.
- : Click to access PTZ controls.

NOTE: PTZ camera(s) must be connected. For instructions, see “Appendix C: Connecting PTZ Cameras” on page 108.
- : Click to close the on-screen keyboard and cancel current entry.

Using the On-Screen Keyboard

An on-screen keyboard appears when entering certain menu options that require text input (for example, Email setup).



To use the on-screen keyboard:

- 1 Click on a menu field that requires text.

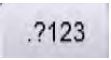
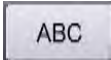

- The on-screen keyboard appears.
- Click  for numbers or special characters (e.g. ".", "@", etc.). Click  to go back to letters.



NOTE: For additional special characters, click  from the numerical keyboard.

- Click  to delete characters.
- Click  to confirm entry.
- Click  to cancel entry and exit keyboard.

Using the Split-Screen Selector

The Split-Screen Selector allows you to choose the grid layout for Split-Screen view. Quad (4-way), 9-way, and 16-way (16-channel only) split options are available.

To use the Split-screen Selector:

- 1 Click  to open the Split-Screen Selector. If you are in Full Screen / Single Channel view, click  to go to Split-Screen view, and click  again to open the Split-Screen Selector.
- 2 Click a grid configuration for live viewing or playback:

- **8-channel:** Choose from quad (CH1~4, CH5~8) or 9-way split (the bottom-right square appears blacked out).
- **16-channel:** Choose from quad (CH1~4, CH5~8, CH9~12, CH13~16), 9-way split (CH1~9, CH10~2), or 16-way split (CH1~16).



Split-screen Selector (8-channel)

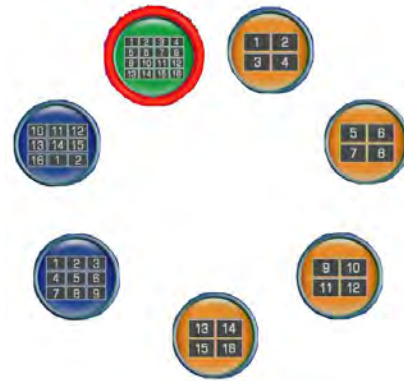

Split-screen Selector (16-channel)

Flexible Camera Assignment (Swipe-to-Switch)

In Split-Screen view, you can re-assign your cameras to different positions. For example, you can duplicate the video feed from channel 1 onto channel 2. This is useful if you wish to obscure the number or location of your cameras.

NOTE: The DVR records cameras to their designated channels even if you reassign camera positions.



Example: Channel 3 is reassigned to channel 5.

To re-assign camera positions using a mouse:

- 1 Select the channel you want to re-assign.
- 2 Click and hold the mouse.
 - A camera menu appears.
- 3 While holding, move the mouse to the left or right to change the camera. Release the mouse button when the desired camera is highlighted to select it.



To re-assign camera positions using a touch screen monitor:

- 1 Press and hold your finger on the channel you want to re-assign.
 - A camera menu appears.

NOTE: Tapping on the screen may cause the DVR to switch to Single-Channel / Full-Screen mode. If it does this, press the

 button to return to Split-Screen view.

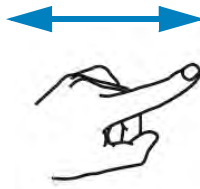



- 2 Move your finger from left to right to change the channel. Release your finger when the desired camera is highlighted to select it.

Using Sequence View

In Sequence view, the DVR automatically switches between camera channels every few seconds (for instructions on changing the amount of time channels are shown before switching, see “Changing the Sequence Dwell Time” on page 32). The following modes are available for Sequence view:



- **Single-channel Sequence:** The DVR automatically switches between connected cameras in full-screen.
- **4-way Sequence:** The DVR switches between every channel, showing 4 channels at a time.

To enter / exit Sequence view:

- Click  to enter Sequence view. Sequence view uses the last mode selected.
- Click  to exit Sequence view and return to Split-Screen mode.

To change the Sequence mode:

- 1 Click  while viewing in Sequence view. The Sequence Mode Selector appears.

- 2 Click  to select 4-way Sequence or  for Single-channel Sequence.

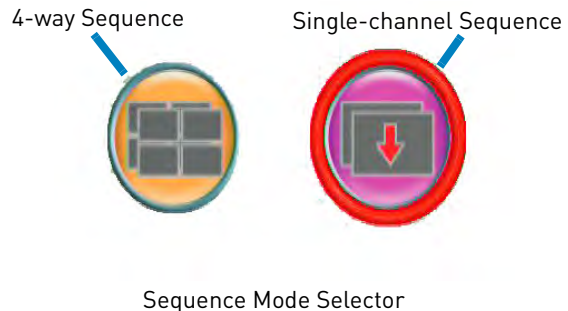



Setting the Date and Time



It is highly recommended to immediately set the date and time when first setting up your DVR.

Inaccurate time stamps may render your footage unusable as court evidence.

To set the date and time:

- 1 Click  to open the Main Menu.
- 2 Click  to open the Setup Menu.
- 3 Click **Date/Time Setup**. The Date/Time Setup Menu appears.

4 Configure the following:

- **Date Mode:** Scroll up / down to select the date format you would like to use (**Y/M/D**, **D/M/Y**, or **M/Y/D**). The Date field automatically changes to the chosen format when selected.
- **Date Setup:** Scroll up / down to manually select the date.
- **Time Setup:** Scroll up / down to manually select the time.

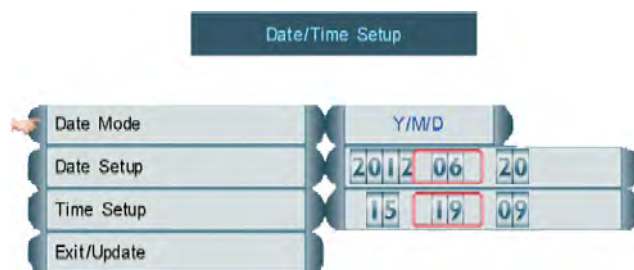

Date/Time Setup Menu

NOTE: The DVR displays time in 24-hour format.

- 5 Click **Exit/Update** to save your settings. The system returns to the Setup Menu.
- 6 Right-click until all menus are closed. The date and time are displayed on the bottom-left corner of the screen.

NOTE: The system does not automatically adjust the time for Daylight Savings Time. Remember to change the time one hour ahead, or one hour backward, according to Daylight Savings Time. When the time is set backwards, the system will retain recorded data with overlapping time stamps.



Recording

By default, the system is set to immediately record video from all connected cameras in Continuous Record Mode.

You can set the system to stop recording once the hard drive is full, or to continually record by overwriting previously recorded data. For more details, see “Record” on page 35.

Event Recording

The DVR includes the following modes of event recording:

-  **Motion:** The DVR records when motion is detected by the affected camera.
-  **Video Loss:** The DVR records when a camera is disconnected or suffers video loss.

The system employs a pre-record function to capture video seconds before events occur.

Recording Audio

The system can record one audio channel. You must have an audio-enabled camera or self-powered microphone connected to the system in order to use this function.

For details, see “Appendix D: Recording and Playing Audio” on page 111.

Event List

The system features an Event List to organize and search for recorded video on the system. Events in the Event List are marked with Smart Search icons, which allows you to search for recorded data on your system quickly and easily.

NOTE: The system can save a maximum of 8196 events.



To access the Event List:

- Click **LIST** or press the **LIST** button on the remote control.

NOTE: You cannot access the Event List using the buttons on the front panel of the DVR.



- 1 Channel Filter:** View data from all cameras or from individual cameras.
- 2 Smart Search:** Filter events through Smart Search icons, which indicate the type of event.
- 3 Event Details:** View details for the event, including date & time and event source.
- 4 Events:** List of recorded events on the system.

- 5 **Active Toolbar Buttons:** While in Event List, click  to select events for playback, Trash () to delete events (**cannot undo**), and  to exit.

Channel Filter

Use the Channel Filter to sort the data from individual channels or all channels.



NOTE: Filters for channels 9~16 are shown in the Event List for the 8-channel model but are not click-able.

Event Details

An event number, camera number, filter type, date & time, and event source are shown for each event in the Event List. When you use the Channel Filter and Event Filter, the Event Details Bar Helps you view event details at a glance.

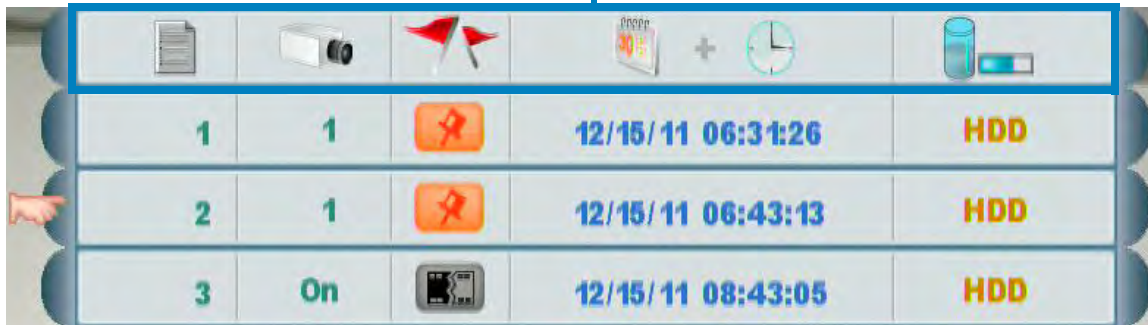
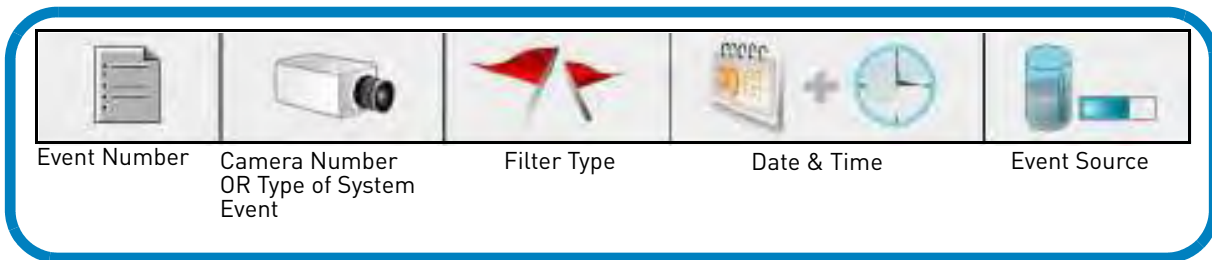



Event Details Bar







Searching for Recorded Data (Scroll-to-Search)

Scroll-to-Search allows you to easily search through saved events and see a preview of the recorded video. You can access the Event List from Viewing mode and Playback mode to search for recorded data on your system.

To search for data:

- 1 From the main screen, click . The Event List opens.
- 2 Under Channel Filter, click  to view events for *ALL* channels, or click the Channel icons to view events from *individual* channels.

3 Click the **Smart Search icons** to sort the data according to the following:

-  **ALL:** View all events chronologically.
NOTE: USB backups appear at the top of the list if a USB flash drive with saved backup data is connected.
-  **Motion:** Motion events from the selected camera(s).
-  **Video Loss:** Camera(s) are disconnected or suffer video loss. The system employs a pre-record function to capture video seconds before the loss of video occurred.
-  **HDD/System:** Hard drive connection / disconnection, power loss, or disk failure. Shows D/T when the system date and time has been changed.
-  **Power ON/OFF:** System ON/OFF.
-  **Playback Mark:** A personal marker set by the user during Playback Mode. For details, see “The Playback Bar, Playback Markers, and Smart Search Markers” on page 25.
-  **USB:** USB backup performed by the user.



4 Scroll up / down to view the events on the list.

- With a touch screen monitor, touch inside the list of events and move your finger up / down to scroll.

5 Click an event. A preview of the recorded video appears behind the Event List window.

6 Click . System switches to Playback Mode.

NOTE: If the Playback toolbar does not appear, click .

NOTE: You cannot begin playback after clicking  or .

7 To exit, right-click until you return to the main screen.

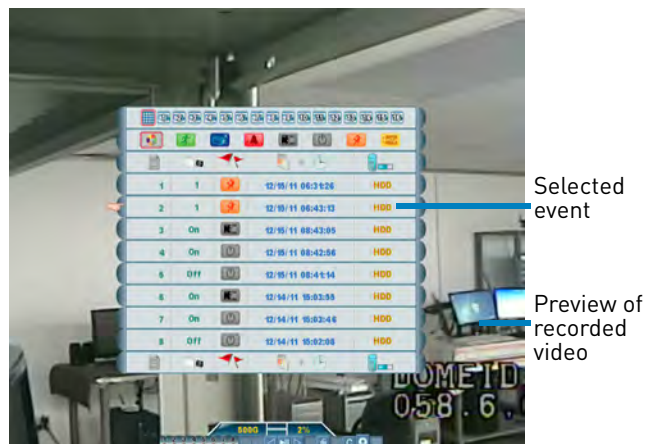

Scroll-to-Search shows you a preview of your recorded video when you select an event

Playback

Playback mode allows you to view video recordings saved on your DVR. You can playback video from a single channel in Single-Channel / Full-Screen mode or from multiple channels in Split-Screen view.



Playback display view





To begin playback:

- 1 From the main screen, click . Playback mode opens.

NOTE: If the Playback Toolbar is not visible, click .

- 2 Click and scroll up / down to select the date, month, year, time, and / or frame for playback and click  to begin playback.

- 3 During playback, you have access to the following:

- : Click to pause playback; press again to resume playback.
- : Click to rewind / increase rewind speed (5X, 15X, 60X).
- : Click to fast forward / increase fast forward speed (5X, 15X, 60X).
- : Click to open the Split-Screen Selector.
- : Click to open the Event List. See "Event List" on page 21.

- 4 Click any channel to view the selected channel in Full-Screen / Single-Channel mode.

- 5 Click inside the Playback Bar to set a Playback Marker. Playback Markers can be used for faster searching in the Event List. See "The Playback Bar, Playback Markers, and Smart Search Markers" on page 25.

NOTE: You can only create Playback Markers in Full-Screen / Single-Channel mode.

- 6 Right-click anywhere on the screen to exit and return to Viewing mode.

The Playback Bar, Playback Markers, and Smart Search Markers

The Playback Bar shows recorded video data and events on the DVR based on the time they were recorded. The Playback Bar is black when there is no video available for a given time, and it is colored when video is available for a given time.



Playback Bar

Playback and Smart Search Markers

Events on the DVR are represented by different colored markers (see the diagram below). These markers are part of the Smart Search functionality of the system. For more details on Smart Search, see “Event List” on page 21. You can also create your own Playback Markers at any point during Playback mode.



Search markers¹

To create Playback Markers:

- Click anywhere inside the Playback Bar. A Playback Marker appears at the Playback Target. An event is also added to the Event List with a  icon.

To use Smart Search and Playback Markers:

- 1 Scroll up / down to position one of the colored markers in the **Playback Target**.
 - Using a touch screen monitor, touch any of the Time and Date Selectors and move your finger up / down.
- 2 Click .

1. Graphics simulated.

Taking Screenshots

ATTENTION: Video footage is preferable to screenshots when submitting surveillance evidence in court. For instructions on how to backup or extract video footage from your DVR, see "Backup" on page 43.

You can take screenshots (screen captures) of the main display of your system at any time: during live viewing, search, and playback, or in any system menu. Screenshots are useful if you need to provide a still image of your security footage to the authorities.

NOTE: A USB flash drive (not included) must be connected to the system and formatted in order to take screenshots. For instructions on how to format USB flash drives, see "Formatting the USB Drive" on page 43.

To take a screenshot:

- 1 Connect a USB flash drive (not included) to one of the USB ports on the DVR. Format the USB flash drive if you have not already done so.
- 2 If you want to capture a moment in Viewing or Playback mode, select the display view for the screenshot: full-screen or split-screen.
- 3 Click . The screenshot appears in the center of the main display, followed by the file name. Screenshots are saved to the *Picture* folder on the USB flash drive.



Screenshot being taken on the system

NOTE: Screenshots are saved as JPEG files with the following naming convention:
NmmDD00x.jpg

| Filename | Definition |
|-----------|------------------------------------|
| N | System file marker |
| mm | Month |
| DD | Day |
| x | Numeral (e.g. 001, 002, 003, etc.) |

Using Screenshots

Once you have taken screenshots, connect the USB flash drive to a computer to view, print, or archive the images.

To use screenshots (Windows):

- 1 Connect the USB flash drive to a USB port on your computer. In the AutoPlay window, select **Open folder to view files**.

NOTE: If AutoPlay does not start, search your computer for a *Removable Disk*.

- 2 Double-click the **Picture** folder.
- 3 Perform one of the following:
 - **View:** Double-click the screenshot to view it in an image viewing or editing program, such as Windows Picture Viewer or Adobe® Photoshop™
 - **Archive:** Copy the images to a folder on your computer
 - **Print:** Right-click the image and select **Print** to print it directly from Windows Explorer, or print the screenshot from an image viewing or editing program.

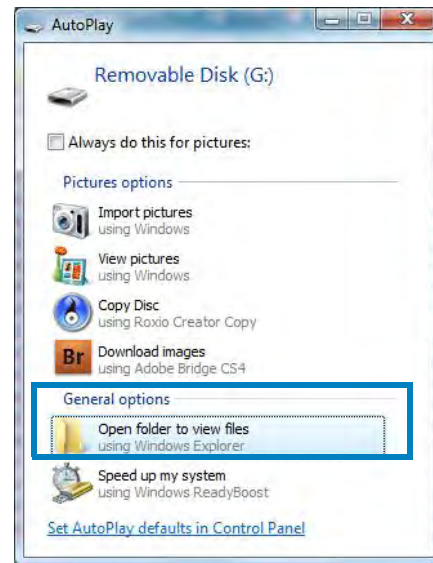

AutoPlay window

To use screenshots (Mac OS):

- 1 Connect the USB flash drive to a USB port on your computer. It appears on your desktop.

NOTE: If the USB drive does not appear, open Finder and locate the USB flash drive under Devices.
- 2 Double-click the USB flash drive.
- 3 Double-click the **Picture** folder.
- 4 Perform one of the following:
 - **View:** Double-click the screenshot to view it in an image viewing or editing program, such as Preview or Adobe® Photoshop™
 - **Archive:** Copy the images to a folder on your computer.
 - **Print:** Print the screenshot from an image viewing or editing program.

Managing Passwords

ATTENTION: By default, passwords are disabled on the system, which allows anyone to access the menus and change DVR settings. It is recommended to enable passwords. See “Enabling and Disabling Passwords” on page 29.

Refer to the tables below for the user name (ID) and password required to log in to your system:

Local DVR Access:

| LEVEL | ID | PASSWORD |
|-------|----|----------|
| USER1 | 1 | 1111 |
| USER2 | 2 | 2222 |
| ADMIN | 3 | 3333 |

Remote/LAN Access:

| LEVEL | ID | PASSWORD |
|-------|----|----------|
| USER1 | 7 | 1111 |
| USER2 | 8 | 2222 |
| ADMIN | 9 | 3333 |

User Accounts

The DVR has three user accounts: ADMIN, USER2, and USER1. The ADMIN account is the system administrator. The ADMIN can access all the menus and can configure the DVR both locally and from a remote computer. The ADMIN can also see covert cameras when he is logged in from a remote computer or mobile device. For information on covert cameras, see “Configuring the Covert Setting (Hidden Cameras)” on page 31.

USER2 is the standard user account. USER2 can access all the menus on the DVR except for the Setup Menu. USER2 can view and backup recorded footage when logged into the DVR from a remote computer or mobile device but cannot access the remote setup menu or see covert cameras.

USER1 is a limited access user account that cannot access any menus on the DVR. USER1 can view cameras when logged in from a remote computer or mobile device but cannot access the setup menus, view or backup recorded video, or see covert cameras.

Using the Password Wheel

The Password Wheel is used to input and change user IDs and passwords.

To use the Password Wheel:

- Click **0~9** to enter your user ID and password.

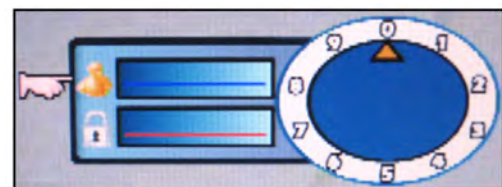



Login with your user ID and password using the Password Wheel

NOTE: You cannot select the options to the left of the Password Wheel (user ID, password)—you can *only* select the digits. If you make a mistake, simply right-click to exit or click  and re-select the option to try again.

Enabling and Disabling Passwords

By default, passwords are disabled. With passwords enabled, you need to enter your user ID and password to access the system Main Menu, Event List, or Playback mode.

To enable/disable passwords:

- 1 Click  to open the Main Menu. Enter your user ID and password if needed.
- 2 Click . The Setup menu opens.
- 3 Click **DVR Password**. The DVR Password menu opens.
- 4 Click **Password Enable** and scroll up / down to select **O** to enable passwords or **X** to disable.
- 5 Right-click until you have exited all menus to save your changes.



DVR Password Menu



NOTE: When you are logged in, this icon is shown at the top-left corner of the screen: .

The number represents your user ID. To log out, right-click or click  from Viewing mode.

Changing Passwords

If passwords are enabled, you must be logged in as ADMIN in order to change passwords.

To change passwords:

- 1 Click  to open the Main Menu.
- 2 Click . The Setup menu opens.
- 3 Click **DVR Password**. The Password Wheel opens. Enter the ADMIN user ID and password if needed.
- 4 Click the account you would like to change.
- 5 Use the Password Wheel to enter a 4-digit password. Enter it again to confirm.
- 6 Right-click until you have exited all menus to save your changes.

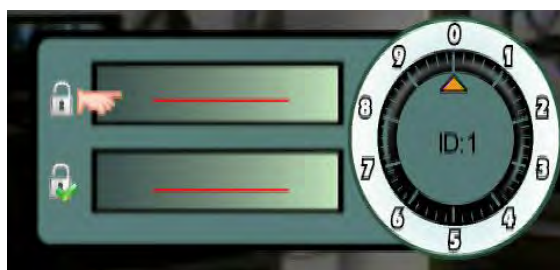

Enter the new password twice to change passwords



Password change confirmation

NOTE: To change the Remote Access passwords see "Configuring Remote Access Passwords" on page 47.

Using the Main Menu

To open the Main Menu:

- Click **MENU**, **OR** press the  button on the front panel of the DVR. Click on the icons below to open sub-menus.

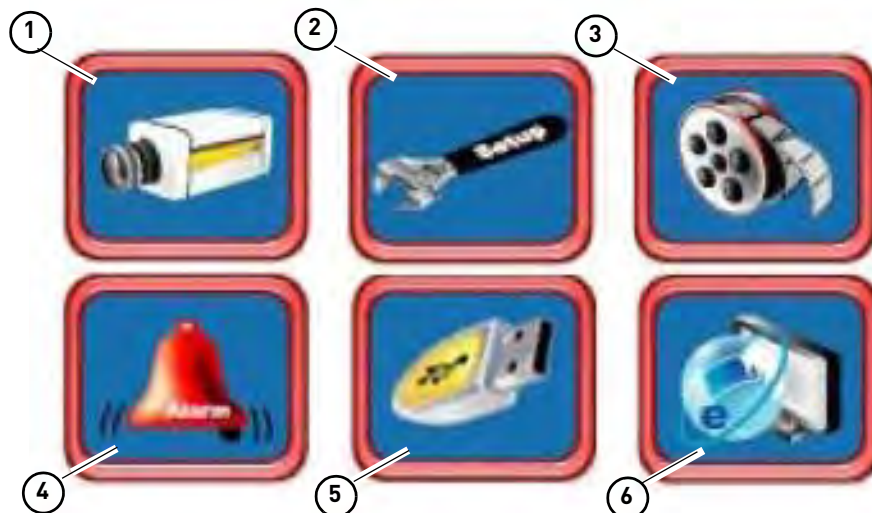

- 1 Camera:** Adjust brightness, contrast, hue, and saturation for each camera. Configure camera title display, sequence time, and Covert (hidden camera) settings.
- 2 Setup:** Configure date / time, language, video settings, passwords, and fan speed. View system information.
- 3 Record:** Configure video parameters for recording. Configure recording mode and schedule. Configure camera frame rate, video quality, resolution, and audio settings. Format hard drive. View video information.
- 4 Alarm:** Configure alarm, motion, and video loss settings. Enable / disable system buzzers.
- 5 Backup:** Backup recorded video to a USB flash drive. Select start time, stop time, and video channel for backup. Format connected USB flash drive.
- 6 LAN:** View / configure networking settings.



Tip!

See the "Controls Quick Reference" on page 13 for instructions on navigating the menus with the various control options available.



Camera

The Camera Menu allows you to adjust the picture settings for your cameras and configure camera title display, sequence time, and Covert (hidden camera) settings. Configure PTZ cameras (RS-485 settings).

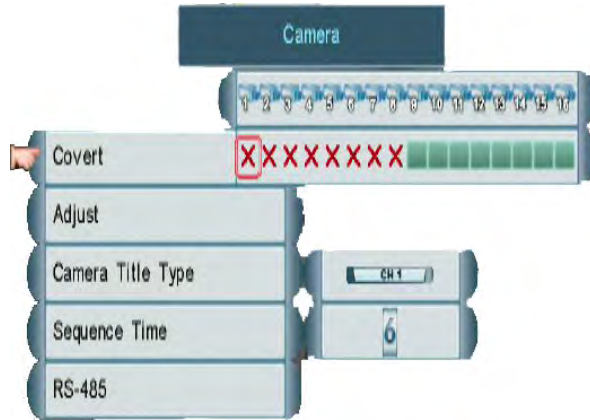

Camera Menu

To access the Camera Menu, click **MENU** then

- For instructions on configuring PTZ cameras, see “Appendix C: Connecting PTZ Cameras” on page 108.

Configuring Camera Color Settings

- 1 From the Camera menu, select **Adjust**.
- 2 Select the camera you would like to configure. The Camera Color Settings Menu opens.
- 3 Configure the following:
 - **Brightness**
 - **Contrast**
 - **Hue**
 - **Saturation**

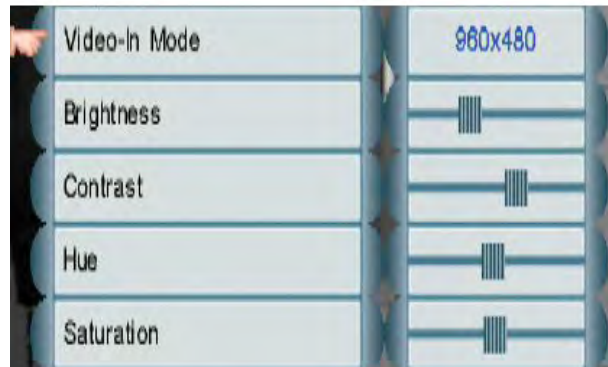

Camera color adjust settings

- 4 Scroll up / down to increase / decrease the value for the selected option.
- 5 Right-click to save your settings and return to the Camera menu.

Configuring the Covert Setting (Hidden Cameras)

The Covert setting allows you to hide cameras on the DVR, so users cannot see them. Cameras that are hidden using the Covert setting can only be viewed remotely (i.e. through a local network or the Internet) by the ADMIN account.



NOTE: It is highly recommended to enable passwords when using the Covert settings. If passwords are not enabled, then anyone can change Covert settings and un-hide the cameras. If passwords are enabled, only the ADMIN and USER2 accounts can change Covert settings.

To configure Covert settings:

- 1 From the Camera Menu, click **Covert** under the camera you would like to hide / un-hide.
- 2 Move the cursor to the camera you would like to hide / un-hide and scroll up / down to change the Covert settings.
 - **X** - Visible (Covert OFF).
 - **O** - Hidden (Covert ON).

- 3 Right-click until you have exited all menus to save your settings.

Changing the Camera Title Display

- 1 From the Camera Menu, click **Camera Title Type**.
- 2 Scroll up / down to select the type of label that you would like to appear above your cameras:
 -  : Displays the name of the camera. You can create custom titles for your cameras using the Client Software or DVR Netviewer. For details, see "Creating Custom Camera Titles" on page 71.
 -  : Displays the channel number.
 -  : Displays no title.
- 3 Right-click to save your settings and return to the Main Menu.

Changing the Sequence Dwell Time

Sequence time refers to the amount of time a channel appears on the screen before changing to a different channel when the DVR is in Sequence view. For example, when Sequence view is on, channel 1 is shown for several seconds before switching to channel 2.

To change sequence time:

- 1 From the Camera Menu, click **Sequence Time**.
- 2 Scroll up / down to adjust the sequence duration.
 - To enter Sequence view, click  in the menu bar from Viewing mode.
- 3 Right-click to save your settings and return to the Main Menu.

Changing the Camera Input Mode (EDGE3 Only)

The Video-In Mode is used to select if your DVR inputs video from cameras in wide-screen formats (such as 960H; 960x480) or standard formats (such as 720x480).

By default, the system is set to input all cameras in 960H format. 960H will enable larger, wide-screen formats, but it will decrease the number of Frames Per Second available for recording. It is recommended to select 720x480 if you do not have cameras that are 960H-capable.

To change the camera input mode:

- 1 From the camera menu, click **Adjust**.
- 2 Select the camera you would like to configure.
- 3 Under **Video-In Mode**, select **960x480** for 960H cameras (the DVR will use the wide format resolutions for this camera) or **720x480** (the DVR will use the standard resolutions for this camera) for non-960H cameras.



Select 960x480 for 960H cameras or 720x480 for non-960H cameras

- 4 Right-click repeatedly to return to live viewing.





Setup

The Setup Menu allows you to configure system settings including, the date / time, language, video settings, passwords, and the internal fan speed. You can also view system information or reset the DVR to factory settings.



Setup Menu

To access the Setup Menu, click  then .

- To change the date and time, see “Setting the Date and Time” on page 19.
- To enable or configure DVR passwords, see “Managing Passwords” on page 28.

Changing the Resolution and Video Output Mode

- 1 From the Setup Menu, click **Video-Out Setup**. The Video-Out Setup Menu opens.
- 2 Click **Video-Out Resolution**. Scroll up / down to select your video output type (VGA or HDMI) and resolution or select **Auto** for the DVR to automatically detect the best resolution for your monitor (recommended).
- 3 Click **Video-Out Update**.
- 4 Click **Yes** to save your changes or **No** to discard them. If you do not select Yes or

No, the DVR will return to the previous resolution setting in 30 seconds.

- 5 Right-click to return to the Setup Menu.

Accessing System Information

- From the Setup Menu, click **Information**. Right-click to exit the Information window.

Changing the Fan Speed

Changing the fan speed affects the internal temperature of the DVR.

- 1 From the Setup Menu, click **Fan Speed**. Scroll up / down to select **High**, **Medium**, or **Low**.
- 2 Right-click to save your settings and return to the Main Menu.

Selecting PAL or NTSC

- 1 From the Setup Menu, click **NTSC/PAL Select**. Scroll up / down to select **NTSC** (for North America), **PAL** (for Europe), or **Auto** (the system automatically detects the format of the connected cameras, recommended).
- 2 Right-click to save your settings and return to the Main Menu.



Changing the System Language

- 1 From the Setup Menu, click **Language**. Scroll up / down to select the language.
- 2 Right-click to save your settings and return to the Main Menu.

Adjusting HDMI Screen Size

On some HDTV's, the top or bottom of the screen may be cut off by the display. If this happens, follow the steps below.

To adjust HDMI Screen Size:

- 1 Click  or press  on the front panel of the DVR to open the Main Menu.
- 2 Click  to open the Setup Menu.

- 3 Click **Video-Out Setup**. The Video-Out Setup Menu opens.
- 4 Click **HDMI Screen Size**, and scroll up / down to adjust the screen size.

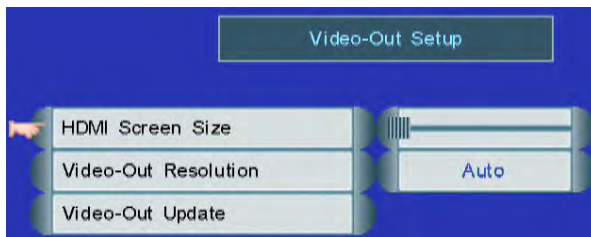

Click HDMI Screen Size and scroll up / down to adjust the screen size

NOTE: Adjusting the HDMI Screen Size setting has no effect if the monitor is connected with a VGA cable.

- 5 Right-click until you have exited all menus to save changes.

Resetting the DVR to Factory Default Settings

ATTENTION: Resetting to Factory Default Settings will not erase your recordings, but it will erase all event and playback markers in the Event List. **This cannot be undone.**

- 1 From the Setup Menu, click **Config Setup**.
- 2 Click **Load Factory Default**.
- 3 Click **Yes** to confirm or **No** to cancel. Please allow a few moments for the system to reset.

Saving your System Configuration to a USB Flash Drive

You can save your current system configuration to a USB flash drive (not included). This allows you to save all of your current settings for backup purposes.

NOTE: This function only saves settings created in system menus. It

does not save or backup any video.

To save your system configuration to a USB flash drive:

- 1 Connect a USB flash drive (not included) to one of the **USB** ports.
- 2 Format the USB flash drive with the DVR if you have not done so already. For instructions, see "Formatting the USB Drive" on page 43.
- 3 From the Setup Menu, click **Config Setup**.
- 4 Click **Save Config to USB** and then click **Yes** to confirm.

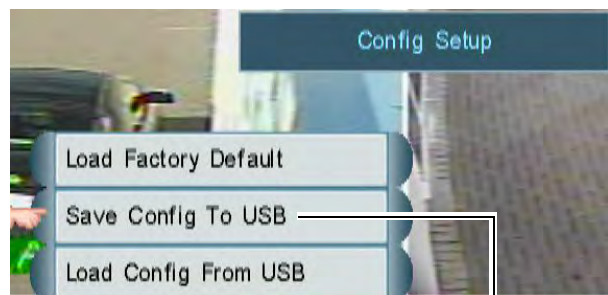

Click to save DVR configuration to a USB flash drive (not included)

- 5 Wait until the save is completed.

Loading a System Configuration from a USB Drive

- 1 Insert a USB flash drive (not included) with a saved configuration file into one of the **USB** ports.
- 2 From the Setup Menu, click **Config Setup**.
- 3 Click **Load Config from USB** and then click **Yes** to confirm.
- 4 Wait for the system to finish restoring the configuration. **Do not pull the power plug or power off the DVR during while the configuration is restored.** The DVR will restart once it is finished.



Record

The Record Menu allows you to configure video recording parameters, including recording mode, schedule and camera video settings. Camera video settings include the video frame rate, image quality, resolution, and audio settings. It also allows you to format hard drives or configure your external hard drive (not included) for disk mirroring or expansion.



Record Menu

To access the Record Menu, click **MENU** then .

To configure camera audio settings, see "Appendix D: Recording and Playing Audio" on page 111.

Configuring Camera Frame Rate and Video Quality

- 1 From the Record Menu, click **Video Frame Rate**. The Video Frame Rate Menu opens.
- 2 Configure the following:
 - **Alarm/Motion Rate:** This determines the frame rate that is used during alarms or motion events. Click under each camera, and select **X** (DVR will not record during alarms / motion events or will use working rate), **2, 3, 5, 7.5, 10, 15, 30** (FPS¹).

NOTE: Motion Detection must be enabled to record motion events.

1. Frames Per Second

- **Working Rate:** This determines the frame rate used during working hours. Click under each camera, and select **0** (DVR will not record during working hours), **2, 3, 5, 7.5, 10, 15, 30** (FPS).
- **Non-working Rate:** This determines the frame rate used during non-working hours. Click under each camera, and select **0** (DVR will not record during non-working hours), **2, 3, 5, 7.5, 10, 15, 30** (FPS).
- **Real Rate:** The system will automatically calculate and allocate a Real Rate when you set the working rate.
- **Quality:** Click under each camera and select **1, 2, 3, 4, 5**.
- **Resolution:** Click and scroll up / down to select the resolution for all cameras. Available resolutions are:
 - **EDGE2:** 352x240, 704x240, 704x480.
 - **EDGE3:** 360/480x240, 720/960x240, 720/960x480.

NOTE: The slashes in the EDGE3 resolution options show both the wide or non-wide options. The DVR determines which option to use for each camera based on the Video-In Mode setting under MENU→CAMERA→ADJUST. For example, if the Video-In Mode for channel 1 is 960x480, and the resolution on the system is set to 720/960x480, the DVR will record channel 1 at 960x480.

- 3 Right-click to save your changes and return to the Record Menu.

NOTE: As you change the frames, the storage calculator at the bottom of the screen calculates the remaining space on the hard drive.

Reading the Storage Calculator

A storage calculator shows the approximate maximum continuous recording time available on the hard drive based on your settings. Use the storage calculator to help maximize your hard drive space.



Storage calculator

NOTE: The estimation from the Storage Calculator is based *only* on Continuous Recording, not motion or alarm recording.

Configuring the Recording Schedule

The Recording Schedule allows you to configure an hourly or daily schedule for recording. The Recording Schedule is a grid featuring the days of the week and hours 0~23.

To configure the Recording Schedule:

- 1 From the Record Menu, click **Schedule**. The Schedule window opens.
- 2 Click the boxes to switch each half-hour between Working and Non-working hours. Use the Range Selectors below to switch multiple boxes at once.
 - **Working Hour (Yellow):** DVR will record according to the working hour frame rate.
 - **Non-working Hour (Green):** DVR will record according to the non-working hour frame rate.

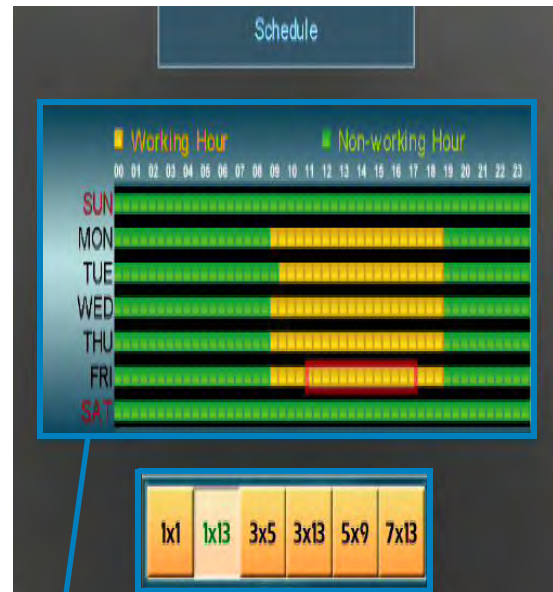

Recording Schedule

Range Selectors

- 3 Right-click to save your changes and return to the Record Menu.

Viewing Hard Drive Information

The HDD Information sub-menu allows you to view information about your hard drives, format your internal or external hard drive (not included), configure overwrite settings, or configure your external hard drive for hard drive extension or mirroring.

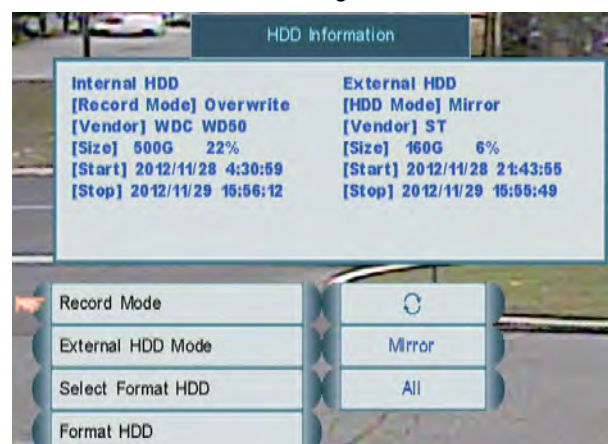

HDD Information

To view hard drive information:

- From the Record Menu, click **HDD Information**.

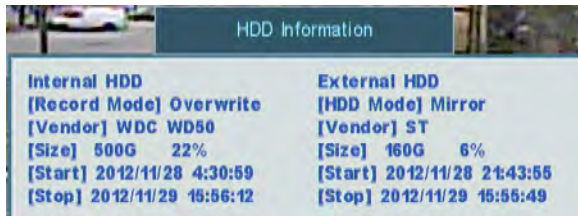



The HDD Information menu shows the following information about your hard drives:

- **Record Mode:** Current recording mode selected.
- **HDD Mode:** Current external hard drive mode selected.
- **Vendor:** Vendor information about your hard drives.
- **Size:** The capacity of your hard drives and the percentage of space used.
- **Start:** The earliest recording saved on the hard drive.
- **Stop:** The most recent recording saved on the hard drive.

NOTE: Depending on your hard drive settings and capacities the Start/Stop time may be different for your internal and external hard drives.

Changing the Record Mode

- 4 From the Record Menu, click **HDD Information**.
- 5 Click **Record Mode**.
- 6 Scroll up / down to change the record mode:
 -  **Single-way:** The system stops recording when the internal hard drive is full.
 -  **Overwrite:** The system continues recording when the hard drive is full by overwriting the oldest recorded data.
 -  **No Record:** The system *does not* record.

- 7 Right-click until you have exited all menus to save changes.

Formatting Hard Drives

If you want to use an external hard drive (not included) for hard drive expansion or mirroring, or if you replace the pre-installed hard drive, it *must* be formatted in order to function properly with the system.

ATTENTION: Formatting the HDD erases **all data** on the hard disk.
This step cannot be undone.

To format the hard disk:

- 1 From the Record Menu, select **HDD Information**.
- 2 Click **Select Format HDD**.
- 3 Scroll up / down to select **Internal HDD** to format the hard drive installed in the DVR, **External HDD** to format your external hard drive (not included), or **All** to format all connected hard drives.
- 4 Click **Format HDD**.
- 5 Click **Yes** to format the hard drive or click **No** to cancel.

Please allow a few seconds for formatting to occur and for the system to reset.

External Hard Drive Mirroring or Extension

You can connect a single self-powered external hard drive (not included) to the rear panel of the DVR. You can use an external hard drive either to expand the total storage capacity of the DVR (HDD Extension) or to have the DVR record to both hard drives simultaneously for backup purposes (HDD Mirroring). You cannot use both HDD Extension and HDD Mirroring at the same time.

NOTE: The DVR supports a single external hard drive up to a maximum size of 2TB. The external hard drive must be self-powered to work with the system; it cannot receive power from the DVR's USB port.

NOTE: Footage on the external hard drive can only be accessed using the DVR or a Windows PC. The footage cannot be accessed on a Mac.

HDD Extension allows you to expand the total storage capacity of your DVR, so you can record longer durations of video. When HDD extension is enabled, the DVR will first record until the internal hard drive is full before it begins to record to the external hard drive. Once the internal and external hard drives are full, it will begin to overwrite the oldest available recordings on the internal hard drive (first in, first out).

Hard Drive Expansion (Example)

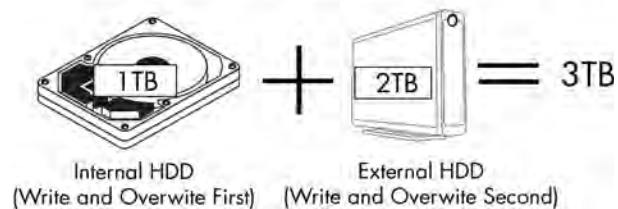

HDD Mirroring is useful if you want to create an automatic backup of your video footage on your external hard drive. This allows you to secure your external hard drive in a locked box or cabinet. This way, if an intruder removes or damages the DVR, you will have a secure backup of the saved footage.

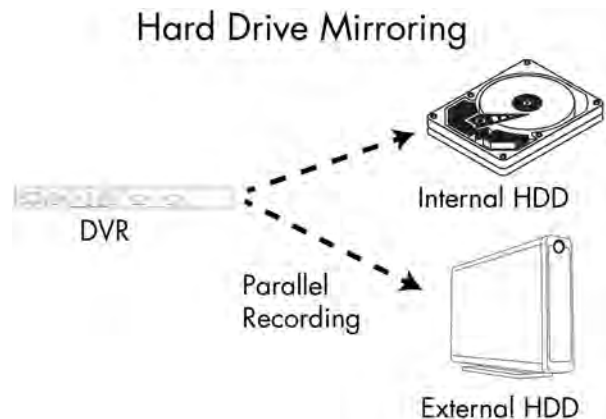

The external hard drive you use for mirroring must be the same size or larger than the internal hard drive to maintain a complete backup of your internal hard drive.

NOTE: HDD Mirroring does not backup data from before HDD mirroring is enabled. The DVR begins parallel recording to both hard drives when HDD mirroring is enabled.

If the external hard drive is larger than the internal hard drive, the DVR will do the following:

- 1 Record in parallel to both hard drives until the internal hard drive is full.
- 2 Begin to overwrite the oldest recordings (first in first out) on the internal hard drive, while continuing to record on the additional capacity of the external hard drive.
- 3 When the external hard drive is full, overwrite the oldest recordings on the external hard drive.

This allows you to keep a backup of your most recent footage as well as a single copy of your oldest available footage on the external hard drive.

Configuring your External Hard Drive for HDD Mirroring or Extension

You can connect a single self-powered external hard drive (not included) to the USB port on the rear panel of the DVR for HDD Mirroring or Extension (see “External Hard Drive Mirroring or Extension” on page 37 for details).

To configure external HDD mirroring or extension:

- 1 Connect an external hard drive to the USB port on the rear panel of the system.

NOTE: The DVR supports a single self-powered external hard drive up to a maximum size of 2TB.
- 2 If you have not done so already, you must format the external hard drive with the DVR to use it with the system. To format the hard drive:
 - From the Record Menu, select **HDD Information**.
 - Click **Select Format HDD** and select **External HDD**.
 - Click **Format HDD** and click **Yes** to confirm. Wait a few seconds for formatting to complete.

ATTENTION - Formatting the external hard drive will erase all data on the drive. You must connect the external hard drive to a Windows PC and use Lorex Client 12 to access the video on the hard drive.

For details, see “Using the HDD Reader (PC Only)” on page 74. The footage cannot be accessed on a Mac.

- 3 Return to the HDD Information menu and click **External HDD Mode**. Scroll up / down to select one of the following:
 - **Mirror:** HDD Mirroring.
 - **Extended REC:** HDD Extension.
 - **Read Only:** Disable recording on the external hard drive and use it to playback recorded footage only.

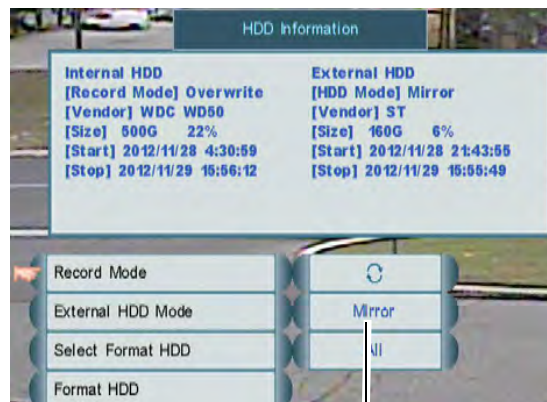

Select Mirror, Extended REC, or Read only

- 4 Right-click and then click **Yes** to confirm your change. Right-click repeatedly to return to live viewing.

NOTE: If you select Extended REC, the hard drive status indicator at the bottom of the screen will indicate the combined size of both the internal and external hard drives. If you select Mirror, the disk full indicator will display the size of the internal hard drive only.

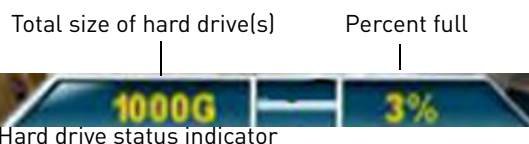

Playing Back Video from the External Hard Drive

When an external hard drive is connected to the DVR, you can playback video from it the same way that you playback video from the internal hard drive. For instructions on using Playback Mode, see “Playback” on page 24.

On the Playback Bar, times with video that are stored on the external hard drive are shown as yellow.

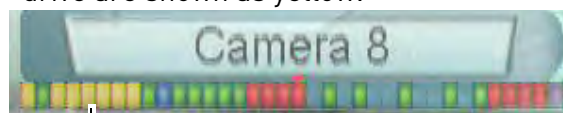

Footage on external hard drive (yellow)



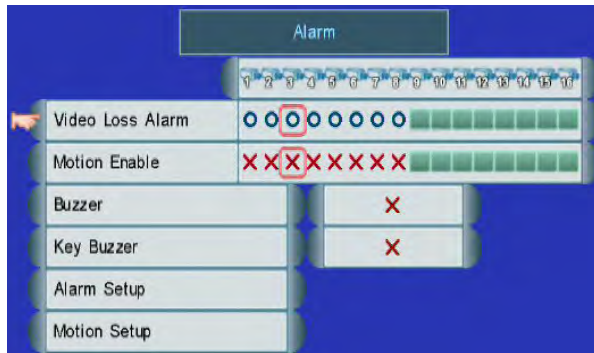

Alarm

The Alarm Menu allows you to configure settings for alarms and motion detection. It also allows you to enable and disable the system buzzers.



Alarm Menu

To access the Alarm Menu, click  then .

Enabling / Disabling System Buzzers

The DVR has two buzzer options, a system buzzer and a key buzzer. The system buzzer beeps during alarms, motion events, and system events. The key buzzer beeps when buttons are pressed.

To enable / disable system buzzer:

- 1 From the Alarm Menu, click **Buzzer**. Scroll up / down and select **0** to enable the system buzzer or select **X** to disable it.
- 2 Right-click to save your changes and return to the Main Menu.

To enable / disable the key buzzer:

- 1 From the Alarm Menu, click **Key Buzzer**. Scroll up / down and select **0** to enable the key buzzer or select **X** to disable it.
- 2 Right-click to save your changes and return to the Main Menu.

Enabling / Disabling Motion Detection

- 1 From the Alarm Menu, click **Motion Enable** under the camera that you wish to configure.
- 2 Scroll up / down and select **0** to enable motion detection or **X** to disable it.
- 3 Right-click to save your changes and return to the Main Menu.

Enabling / Disabling Video Loss Alarms

Video loss alarms occur when cameras are disconnected or suffer a loss of video. The DVR employs a pre-record function to capture video from seconds before the video loss occurred.

To enable / disable video loss alarms:

- 1 From the Alarm Menu, click **Video Loss Alarm** under the camera you wish to configure.
- 2 Scroll up / down and select **0** to enable the video loss alarm or **X** to disable it.
- 3 Right-click to save your changes and return to the Main Menu.

Configuring Alarm Settings

- 1 From the Alarm Menu, click **Alarm Setup**. The Alarm Setup Menu opens.

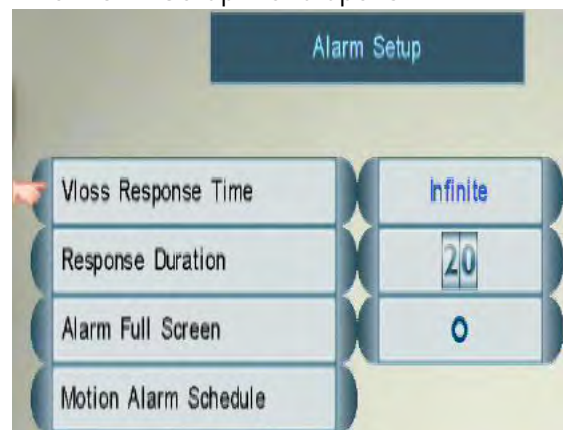

Alarm Setup Menu

- 2 Configure the following:
 - **Vloss Response Time:** Select the time (in seconds) that the buzzer and on-screen message will turn on after a Video loss event.
 - **Response Duration:** Select the time (in seconds) for the DVR to record after a motion event. This also controls the duration of the buzzer and on-screen message.

NOTE: When the buzzer is activated, press any button or right-click to stop it. This does not disable the buzzer for future events.

- **Alarm Full Screen:** Select **0** if you want the DVR to display events (for example, when motion is detected or video loss occurs) in full screen; select **X** to have the DVR remain in its current view when events occur.
- 3 Right-click to save your settings and return to the Alarm Menu.

Configuring the Motion Alarm Schedule

The Motion Alarm Schedule allows you to enable or disable motion events at certain times. This can be useful if you want to set up your DVR to record continuously during business hours and record motion events only outside of business hours.

To configure the Motion Schedule:

- 1 From the Alarm Menu, click **Alarm Setup**. The Alarm Setup Menu opens.

- 2 Click **Motion Alarm Schedule**. The Motion Alarm Schedule opens.

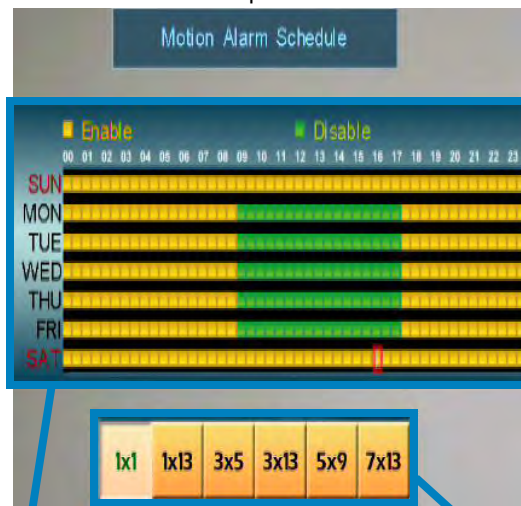

Motion Alarm Schedule

Range Selectors



- 3 Click the boxes to switch each half-hour between Working and Non-working hours. Use the Range Selectors to switch multiple boxes at once.
 - **Enabled (yellow):** Motion events will be enabled during these hours.
 - **Disabled (green):** Motion events will be disabled during these hours.
- 4 Right-click until you have existed all menus to save your changes.

Configuring the DVR for Motion Recording Only

Use the steps below to configure the DVR to disable continuous recording and only record footage that has motion. This allows you to record for a much longer time before the hard drive is full. You can do this on one, some, or all of your cameras.

NOTE: By default, the DVR will overwrite the oldest recordings when the hard drive is full. It can also be configured to stop recording when the hard drive is full. For details, see “Changing the Record Mode” on page 37.

Step 1 of 3: Enable Motion Detection on your cameras:

- 1 While viewing, click  to open the Main Menu.
- 2 Click  to open the Alarm Menu.
- 3 Under cameras that you wish to enable for motion detection, click **Motion Enable** and select **0**.
- 4 Right-click to save your changes and return to the Main Menu.

Step 2 of 3: Configure the Motion Alarm Schedule for 24/7 motion recording:

- 1 From the Main Menu, click  to open the Alarm Menu.
- 2 Click **Alarm Setup**→**Motion Alarm Schedule** to open the Motion Alarm Schedule.
- 3 Configure the Motion Alarm Schedule to enable motion events at all times. The schedule will be solid yellow when motion events have been enabled on a 24/7 basis.
NOTE: Use the range selectors below the Motion Alarm Schedule to configure multiple boxes at a time.
- 4 Right-click until you have returned to the Main Menu to save your changes.

Step 3 of 3: Disable Continuous Recording (Working and Non-working Hours):

- 1 From the Main Menu, click  to open the Record Menu.
- 2 Click **Video Frame Rate**. The Video Frame Rate Menu opens.
- 3 Set both the **Working Rate** and **Non-working Rate** to **0** for cameras that you want to configure for motion recording

only. This disables continuous recording on these cameras.

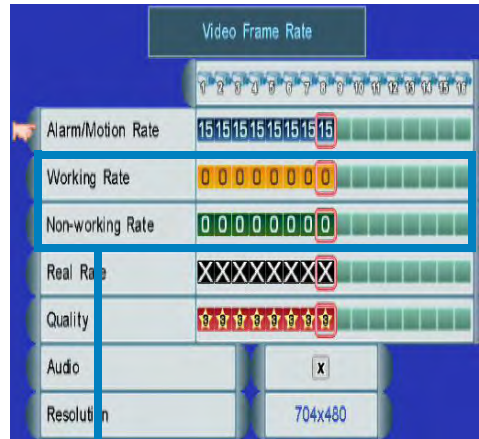

Set the Working Rate and Non-working rate to 0 to disable continuous recording

NOTE: Ensure that the Alarm/Motion Rate is higher than 0 on cameras that you want to configure for motion recording only.

- 4 Right-click repeatedly to save your changes.

Configuring Motion Detection Areas and Sensitivity

You can configure the DVR to detect motion only in certain areas. This can be helpful if you want to only detect motion in an important area (for example, the entrance or driveway of your house) or if normal traffic or movement (for example, from a public street or a tree) in an area is triggering the motion detection.

You can also adjust the motion detection to be more or less sensitive. Higher motion detection sensitivity means that smaller amounts of motion will trigger motion events. Lower motion detection sensitivity means that it will take more motion to trigger a motion event.

To configure motion detection areas and sensitivity:

- 1 From the Alarm Menu, select **Motion Setup**.

- 2 Select the camera you wish to configure. The Motion Detection configuration window opens.

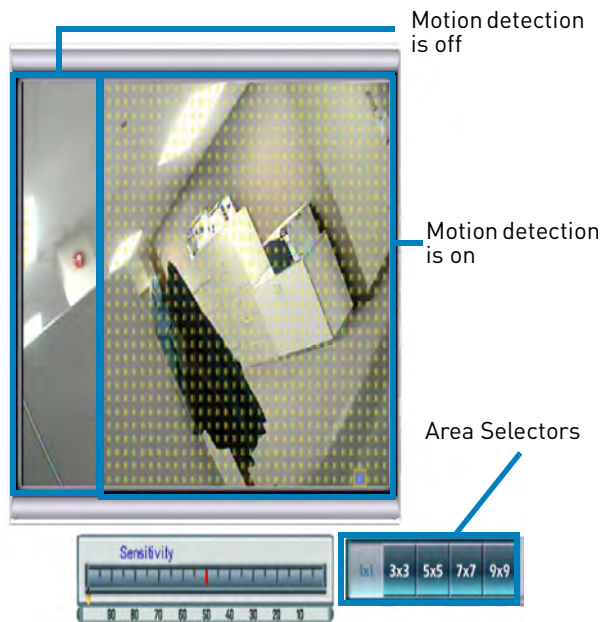

Motion Detection configuration window

- 3 Click the area or areas where you would like to disable / enable motion detection. Areas covered by motion detection are indicated by yellow dots. Use the Area Selectors to enable or disable a larger area.
- 4 Click the Sensitivity bar and scroll up / down to adjust the motion detection sensitivity. A higher sensitivity means that motion events will be triggered by smaller movements. A lower sensitivity means that motion events require larger movements to trigger.



Sensitivity bar

Backup

The Backup Menu allows you to backup recorded video to a USB flash drive (not included) and format a connected USB flash drive.

You must format your USB flash drive before you can backup video from your DVR.

NOTE: The system supports most brands of USB flash drives from 1~ 16GB.



Backup Menu

To access the Backup Menu, click **MENU** then .

For firmware upgrade instructions, see "Appendix G: Upgrading Firmware" on page 118.

Formatting the USB Drive

Prior to backing up data, you must format the USB flash drive so it will work properly with the DVR.

ATTENTION: Formatting erases *all data* on the USB flash drive. This step *cannot* be undone.

To format the USB drive:

- 1 Connect a USB flash drive to one of the **USB** ports on the front or rear panel of the DVR.
- 2 From the Backup Menu, click **Format Device**.
- 3 Click **Yes** to format the USB flash drive or click **No** to cancel.

Please allow a few moments for

formatting to take place. The DVR will display "USB Check OK" when formatting is completed.



Backing up Video to a USB Flash Drive

- 1 Connect a formatted USB flash drive (not included) to a USB port. See above for instructions on how to format a USB flash drive to work with the DVR.
 - 2 From the Backup Menu, click **Select Channel** and select the channel you would like to backup.
 - 3 Click **Start Time**, and select the date, month, year, and time to begin the backup. Event Markers will appear in the Time Bar as you scroll through the date and time.
 - 4 Click **Stop Time**, and select the date, month, year, and time to end backup.
- NOTE:** Event Markers will appear in the Time Bar as you select the Start and Stop times.
- 5 Click **Save to Device**. Backup begins—the on-screen counter displays the progress of the transfer based on the start and stop times selected.
 - 6 To cancel Backup, right-click until you return to the main screen. Please allow a few moments for the system to exit.

NOTE: Backup may take several minutes, depending on the amount of data being transferred.

Confirming Backup

To verify that the file has been properly backed up:

- 1 From Viewing or Playback mode, click  to open the Event List.
- 2 Click  from the Smart Search icons to show backup files only. To view backup

video files, connect the USB flash drive to your computer. For instructions, see "Playing Backed-up Video on your Computer" on page 44.

- 3 To exit, right-click until you return to the main screen.

Backup File Information

Backup files are saved as MOV files to the *Movie* folder on your USB flash drive. These files can be played on the system using Event List or on your PC using QuickTime Player. See "Event List" on page 21.

Backup files are labeled, using the start time specified, according to the following naming convention:

ch##_YYMMDD_hhmmss.mov:

| Filename | Definition |
|----------|-----------------------|
| ch## | Channel number (1~16) |
| YYYY | Year |
| MM | Month |
| DD | Day |
| hh | Hour |
| mm | Minute |
| ss | Second |

Playing Backed-up Video on your Computer

View your saved backup video files using QuickTime Player. You must have QuickTime Player installed to view backup files.

NOTE: For the latest version of QuickTime Player, go to www.apple.com/quicktime/download/

To access backed-up video recordings (PC):

- 1 Connect your USB flash drive to a USB port on your computer. An Autoplay window appears.
- 2 Select **Open Folder to View Files**.
- 3 Double-click the *Movie* folder to open it.
- 4 Double-click files to open them in QuickTime, or move them to a folder on your computer to save them on your computer's hard drive.

To access backed-up video recordings (Mac):

- 1 Connect your USB flash drive to a USB port on your computer. The USB drive appears on your desktop.
- 2 Double-click the USB drive icon () to open your USB thumb drive.
- 3 Double-click the *Movie* folder to open it.
- 4 Double-click files to open them in QuickTime, or move them to a folder on your computer to save them on your computer's hard drive.

Setting QuickTime Player as a Default Media Player (PC)

It is recommended to set QuickTime Player as your default media player. This allows you to double-click on a backed up video file and have the file play automatically.

To set QuickTime Player as your default media player:

- 1 Click on the backed-up video file you wish to view, and right-click.

2 Click **Open With**→**Choose Default Program**.

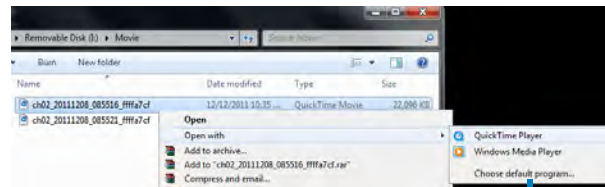

Click Choose Default program

- 3 Under Recommended Programs, select **QuickTime Player** and then click **OK**.





LAN

The LAN Menu allows you to view and adjust the networking settings for the DVR, including the Remote Access user IDs and passwords. **Changing settings in the LAN Menu is not necessary to set up your DVR for remote access.** For instructions on how to set up the DVR for remote access, see “Setting up your DVR for Remote Connectivity” on page 51.

NOTE: For advanced users, tips that will help keep your DVR secure and accessible at all times, even in the event of a power failure are available in “Advanced Networking Configuration (Optional)” on page 61.



LAN Menu

To access the LAN Menu, click  then .

- It is highly recommended to set your DVR up to use a fixed IP address. For more information, see “Appendix B: Assigning a Fixed IP to your DVR” on page 104.

Changing the HTTP Port

For added security, we strongly recommend changing HTTP port 80 on the system to *any desired port*—the port must not be blocked by your Internet

service provider (ISP).

NOTE: Please contact your ISP for complete information on available ports.



If you change the default port on the system from 80 to a different value, you **MUST** enter `http://` and a colon and the port number after the DDNS or IP address when connecting to the DVR using a web browser.

For example, if you change your port number from 80 to 85, you **MUST** enter a colon and port 85 after the DDNS address (for example, `http://tomsmith.lorexddns.net:85`).

Example

Let's say you want to change the HTTP port on your system from 80 to 85.

To change the port number:

- 1 Click  to open the Main Menu, and then click . The LAN Menu opens.
- 2 Click **HTTP Port** and scroll up / down to change the port number to **85**.

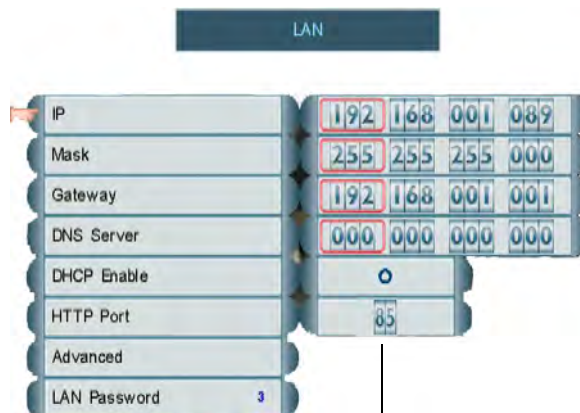

Scroll up / down to change HTTP port

- 3 Right-click to exit and save your settings.
- 4 Disconnect the power adapter from the rear panel of the system. Let the system power-down for 15~20 seconds and then

reconnect the power adapter to the **DC 12V** port.

- To confirm that the new port number is saved on your system, press the  button on the front panel or remote control to view System Information.

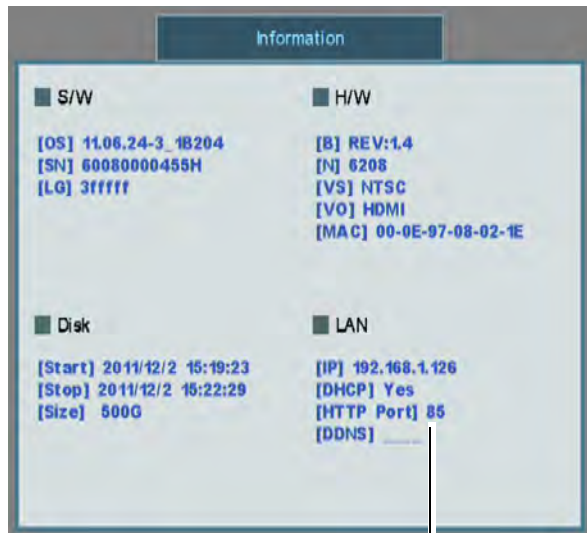

HTTP Port

You must update your DVR List in the Client Software to use the new port. Also, when logging into your DVR with an Internet browser you must include a colon and the HTTP port in the URL after the DDNS address or IP address (for example, *http://tomsmith.lorexddns.net:85*).

If you have already completed router port forwarding, you will need to re-configure your router to forward the newly selected port.

Configuring Network Settings

The following steps are only required if you need to enter a custom IP address, subnet mask, gateway address, or DNS server for your DVR. Consult your router's user guide for details.

- Configure the following:

- IP:** Configure a custom IP address for your DVR. This address will only be used if DHCP is disabled.
- Mask:** Configure a custom subnet mask for your DVR.
- Gateway:** Configure a custom gateway address for your DVR.
- DNS Server:** Configure a custom DNS server for your DVR.
- DHCP Enable:** Scroll up / down and select **O** to enable DHCP or **X** to enable a fixed IP address.

- Right-click to save your changes and return to the Main Menu.

Configuring Remote Access Passwords

Use the LAN Password Menu to control Remote Access passwords for USER1, USER2, and ADMIN profiles. The Remote Access password is required when accessing the DVR over the Internet or a local network.

To change Remote Access passwords:

- From the LAN Menu, select **LAN Password** and enter the ADMIN user ID and password if needed (By default, **ID: 9;** **Password: 3333**).



LAN Password Menu

- Select a user account, and use the Password Wheel to enter the new Remote Access password. Enter it again to confirm.

- **USER1**: Lowest level network user, with access to remote live viewing only. By default: **ID 7; password: 1111**.
- **USER2**: Normal level network user, with access to remote live viewing, playback, and backup only. By default, **ID 8; password: 2222**.
- **ADMIN (Administrator)**: Highest level user, with access to remote live viewing, playback, and setup. By default, **ID 9; password: 3333**

- 3 To save your settings, right-click until you have exited all menus.

NOTE: After changing the LAN passwords, you must clear your browser's cache to connect to the DVR using a web browser.

Configuring Dual Streaming Settings

Dual Streaming settings control the quality and frame rate of video when you connect to the DVR using a computer, smart phone or tablet. Increasing Dual Streaming settings will provide a better image, but requires more bandwidth. Performance may be impacted if insufficient bandwidth is available.

To configure Dual Streaming settings:

- 1 From the LAN Menu, select **Advanced**. Then select **Dual Stream Setup**.
- 2 Under **Bitrate**, select your Internet connection speed between 28.8/36.6kbs (lowest) and Intranet (highest). The Sub Stream Frame Rate and Sub Stream Quality adjust automatically based on your selection.



Dual Stream Setup

- 3 (Optional) You may adjust the **Sub Stream Frame Rate** and **Sub Stream** quality manually. The Bitrate settings adjusts automatically based on your selection.
- 4 Right-click repeatedly to save your changes and exit all menus.

Configuring DDNS Settings



Configure DDNS settings. You must create a DDNS account before you can configure DDNS settings. See "Step 2 of 4: Create a DDNS Account" on page 55.

To configure DDNS settings:

- 1 From the LAN Menu, select **Advanced**. Then Select **DDNS**.



DDNS Setup

- 2 Under DDNS Select, select **LOREX**.
- 3 Click **DDNS User Name** and use the on-screen keyboard to enter the **DDNS User Name** from the confirmation email that was sent to you after registering for DDNS. Click  to confirm.
- 4 Click **DDNS Password** and enter the **DDNS Device Password** from the confirmation email that was sent to you after registering for DDNS. Click  to confirm.
- 5 Click **DDNS Domain Name** and enter the **Domain name/URL Request** from the confirmation email that was sent to you after registering for DDNS. Click  to confirm.

NOTE: If the Domain name/URL request is *tomsmith*, the address to access your video will be *tomsmith.lorexddns.net* using Client Software, or *http://tomsmith.lorexddns.net:80* using a compatible Internet browser.

- 6 Right-click repeatedly to save your changes and exit all menus.

Configuring Email Alerts

You can configure email notifications when an event occurs (for example, when motion is detected by one of your cameras). You must enable motion detection on your cameras to receive email alerts. For instructions, see "Enabling / Disabling Motion Detection" on page 40.

To configure email alerts:



- 1 From the LAN Menu, click **Advanced**. Then select **Mail Setup**.
- 2 Under **Send Mail Status**, select **Default** (recommended) to use the Lorex email server or select **On** to use a custom email server. See the instructions below depending on your selection.



Select Default under Send Mail Status to use Lorex's email server (recommended)

To use the Lorex email server (recommended):

- 1 Click **E-mail Address**.



- 2 Click **Sender's E-mail** and use the on-screen keyboard to enter the sender's email address. This can be any email address of your choice. Click  to confirm.
- 3 Under **Receiver's Email**, enter up to 3 email addresses to receive notifications using the on-screen keyboard. Click  to confirm each entry.





Enter the Sender's email address and up to 3 receivers

- 4 Right-click to return to Mail Setup.
- 5 (Optional) Click **Subject & Location**. Enter a custom email subject and location using the on-screen keyboard. Click  to confirm each entry. Right-click to return to Mail Setup.
- 6 Click **Test Mail** to send a test notification.
- 7 Right-click repeatedly to save your changes.

To use a custom email server:

- 1 Under **Send Mail Status**, select **On**.
- 2 Click **SMTP Server & Port**.
- 3 Click **SMTP Server** and use the on-screen keyboard to enter the email server address. Click  to confirm.
- 4 Click **SMTP Port** and select the email server port number.
- 5 Right-click to return to Mail Setup.
- 6 Click **SMTP User & Password**.
- 7 Click **SMTP User Name** and enter the SMTP user name. Click  to confirm.

- 8 Click **SMTP Password** and enter the SMTP password. Click  to confirm.
- 9 Right-click to return to Mail Setup.
- 10 To enable secure authentication (such as SSL), click **Log on using Secure** and select **O**.
- 11 Click **E-mail Address**.
- 12 Under **Sender's E-mail**, enter the sender's email address using the on-screen keyboard. This can be any email address of your choice. Click  to confirm
- 13 Under **Receiver's Email**, enter up to 3 email addresses to receive notifications using the on-screen keyboard. Click  to confirm each entry.

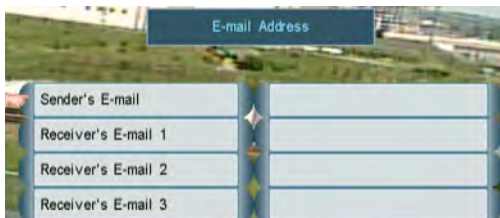

Enter the Sender's email address and up to 3 receivers

- 14 Right-click to return to Mail Setup.
- 15 (Optional) Click **Subject & Location**. Enter a custom email subject and location. Click  to confirm each entry. Right-click to return to Mail Setup.
- 16 Click **Test Mail** to send a test notification.
- 17 Right-click repeatedly to save your changes.

Enabling/Disabling UPnP

The DVR features UPnP compatibility to allow a PC to automatically detect the IP address. For details on how to connect to your DVR using UPnP, see "Connecting to the DVR over a LAN Using UPnP" on page 77.

To enable/disable UPnP:

- 1 From the LAN Menu, click **Advanced**.



Enable/disable UPnP

- 2 Click **UPnP Enable**. Scroll up / down to select **O** to enable UPnP or **X** to disable.
- 3 Right-click repeatedly to save your changes.

Setting up your DVR for Remote Connectivity

The DVR supports two options for remote viewing over a local network (LAN) or the Internet: Client Software (provided on the CD) for PC and Mac and DVR Netviewer, a built-in, browser-based surveillance viewing software.

NOTE: Except where noted, the instructions in this section are the same for PC and Mac.

System Requirements

Prior to using the Client Software or DVR Netviewer, make sure your system meets the following minimum system requirements:

| Description | Requirement |
|----------------------------|--|
| CPU | Intel Pentium® 4 3.0ghz or above (PC) / Intel Pentium Core Duo, 1.66 Ghz or above (Mac) |
| Operating System | Windows™ XP / Vista / 7 / 8 Mac OS 10.5 or above |
| Memory | 128 MB RAM |
| Video | 16 MB of video memory |
| Network (LAN) | 10/100 BaseT Network |
| Network (WAN) | 384 Kbps upstream *High-speed Internet service is recommended when using remote viewing. |
| Browser¹ | Internet Explorer® 6 (or later); Mozilla Firefox and Google Chrome are also supported, but you need to install the IE Tab plug-in. |

1 For the latest compatibility list, visit www.lorextechnology.com.

NOTE: If a user connects to the DVR remotely, there may be slow performance when accessing the DVR locally. This is normal and is not a malfunction.

Accessing your DVR Within a Local Network (LAN)

You can connect to your DVR through the local area network (LAN). It is recommended to confirm connectivity over a local network before setting up your DVR for Internet connectivity.



To complete the steps below, **your computer must be on the same network as the DVR.**

Step 1 of 4: Connect your DVR to the Local Area Network (LAN)

- 1 Power off your DVR by disconnecting the power adapter from the rear panel.
- 2 Connect an Ethernet cable (included) to the **LAN** port on the rear panel of the system. Connect the other end of the Ethernet cable to an empty LAN port (usually numbered 1~4) on your router.

- 3 Reconnect the power adapter to the **DC 12V** port on the rear panel to power the system back on.

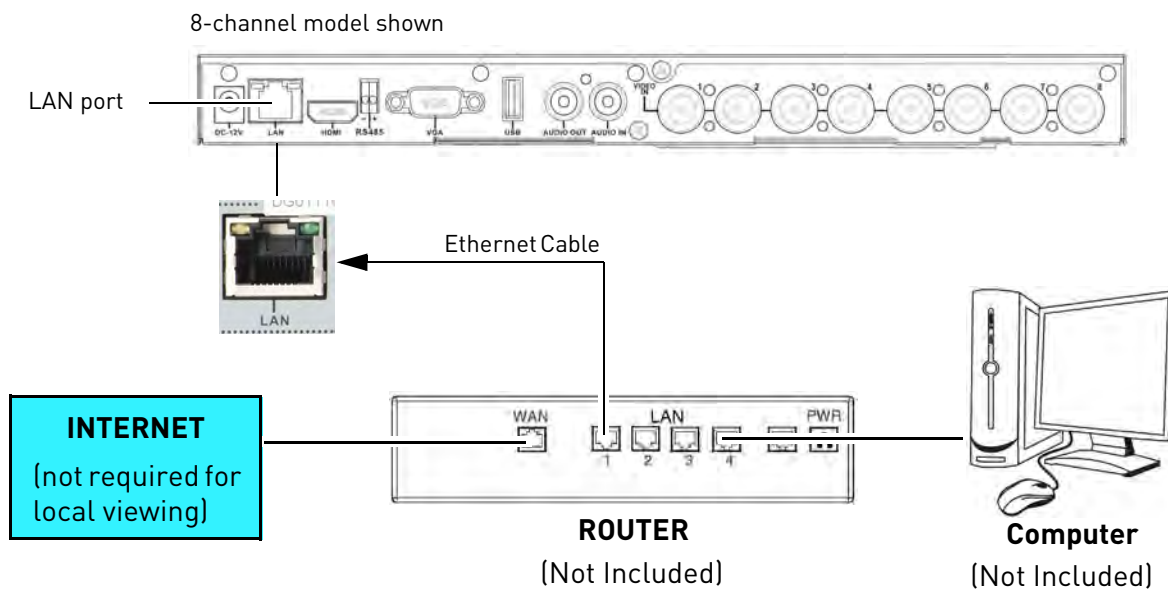

Step 2 of 4: Obtain the DVR's Local IP Address and HTTP Port

- 1 Wait at least 5 minutes after powering up your DVR.
- 2 Press the button on the front panel to bring up the System Information window.

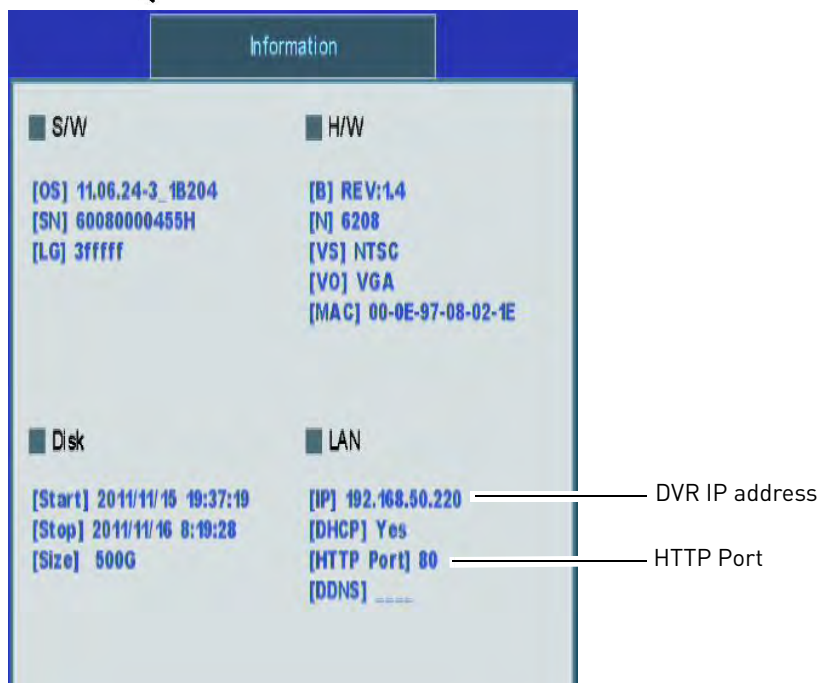

- 3 Write down the IP address and HTTP Port number of the DVR.
 - A local IP address looks something like this: 192.168.50.220.
 - Write down the port number beside the **HTTP Port** field

Step 3 of 4: Install the Client Software on your PC or Mac

Edge Client Software allows you to view and configure Edge Series DVR's over a local network or the Internet. It is included on the software CD that came with your DVR, or available as a free download from www.lorextechnology.com.

To install the Client Software on a PC:

- 1 Insert the software CD into your computer. The Autoplay window opens.
- 2 Click **Run Lorex.exe**.
- 3 Click **DVR Software** then **Lorex Edge Client Software - PC**.
- 4 Follow the on-screen instructions to install.

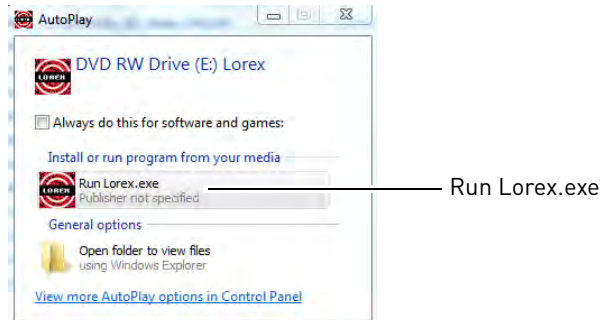

To install Edge Client Software on Mac:

- 1 Insert the software CD into your computer. The Lorex CD icon () appears on your desktop.

- 2 Double-click the **Lorex CD** icon ().

- 3 Open the **Mac** folder.
- 4 Double click the installer file.
- 5 Follow the on-screen instructions to install.

Step 4 of 4: Configure the Client Software and Confirm Local Connection

- 1 (PC) Double-click the **Lorex Client 12** icon () on the desktop. If a security warning appears, click **Yes**. The client window opens.
 - (Mac) Double-click **Edge Client Software** in your Applications folder. The client window opens.

Edge Client Software (Mac)

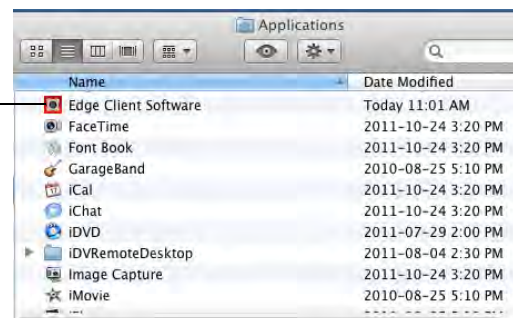

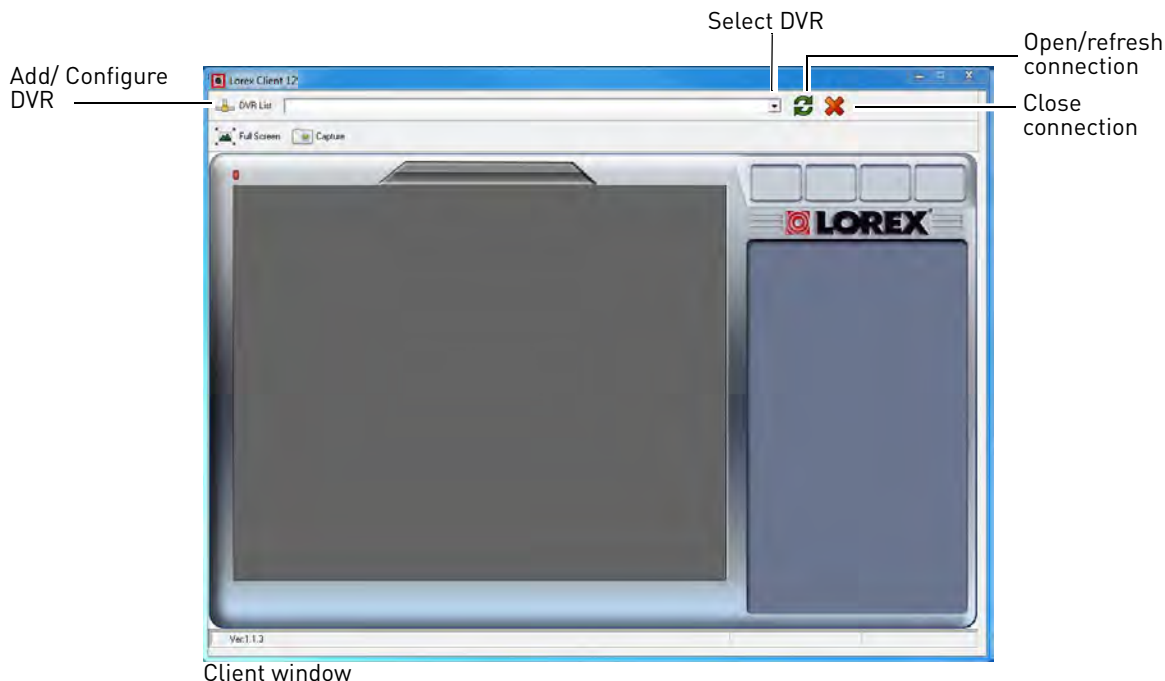

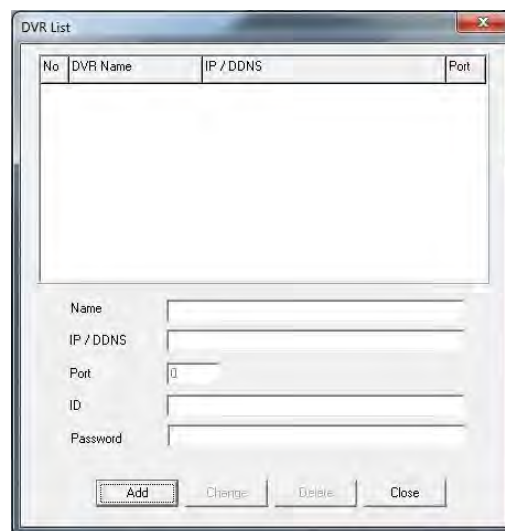

- 2 Click **DVR List**. The DVR List window opens.
- 3 Click **Add**.
- 4 Configure the following:
 - **Name:** Enter the name you would like to use for your DVR. You can use your name, your company or business name, or anything of your choice.
 - **IP / DDNS:** Enter the IP address from the System Information window.
 - **Port:** Enter the HTTP port (default: **80**) from the System Information window.
 - **ID:** Enter the ADMIN ID for remote viewing (default: **9**).
 - **Password:** Enter the ADMIN password for remote viewing (default: **3333**).



DVR List

- 5 Click **Change**. Then click **Close** to return to the main client window.
- 6 Select your DVR from the drop-down menu at the top of the screen and click  to connect. Live video from your cameras will appear when the connection is successful.

NOTE: If it does not connect within 30 seconds, click  and click  again to refresh the connection.

Accessing your DVR Remotely Over the Internet

Setting up remote connectivity allows you to view your DVR from any computer or compatible mobile device with internet access.

To set up remote connectivity with your DVR, you must:

- 1 Port forward the HTTP port (default: **80**) on your router to your DVR's IP address.
- 2 Create a DDNS account.
- 3 Enable DDNS on the DVR.
- 4 Update the Client Software with your DDNS information.

Step 1 of 4: Port Forwarding

You **must** port forward the HTTP port (default: **80**) on your router to your DVR's IP address before you can remotely connect to your system. There are several methods to port forward your router:

- Use the **Lorex Auto Port Forwarding Wizard** (PC only, provided on the CD) to port forward the required ports. For instructions on how to use the Easy Connect Wizard, see the Easy Connect manual on the CD.
- Manually port forward the required ports on your router to your DVR's IP address by following your router manufacturer's instructions. For more information on port forwarding, see the reference guides on www.lorextechnology.com.

NOTE: If the HTTP port is not forwarded on your router, you will not be able to access your system remotely.

NOTE: Certain ISPs (Internet Service Providers) block port 80. If you are unable to connect, check with your ISP and change the HTTP port. see "Changing the HTTP Port" on page 46. If you change your HTTP port, you must update your DVR List in the Client Software for the newly selected port.

Step 2 of 4: Create a DDNS Account

Lorex offers a free DDNS service for use with your system. A DDNS account allows you to set up a web site address that points back to your local network. This allows you to connect to your system remotely. **You must create a DDNS account in the same network as your DVR.**

To setup your free Lorex DDNS account:

- 1 In your browser, go to <http://www.lorexddns.net> and click **Step 1**.

Lorex DDNS - Remote Viewing Setup

A Lorex DDNS account allows you to connect to your Lorex system from anywhere in the world using an easy-to-remember web site address that is available 24/7. This is perfect whether you have a Static or Dynamic IP address - no matter how often your Internet Service Provider changes your IP address, Lorex's exclusive DDNS service will keep you connected to the things that matter to you most.

To set up Lorex DDNS:



- 2 The My Lorex account login screen opens (if you are already logged in, skip to step 4). Create a new account or log into an existing account. To create a new account, fill in the required fields on the right and click **Create Account**.

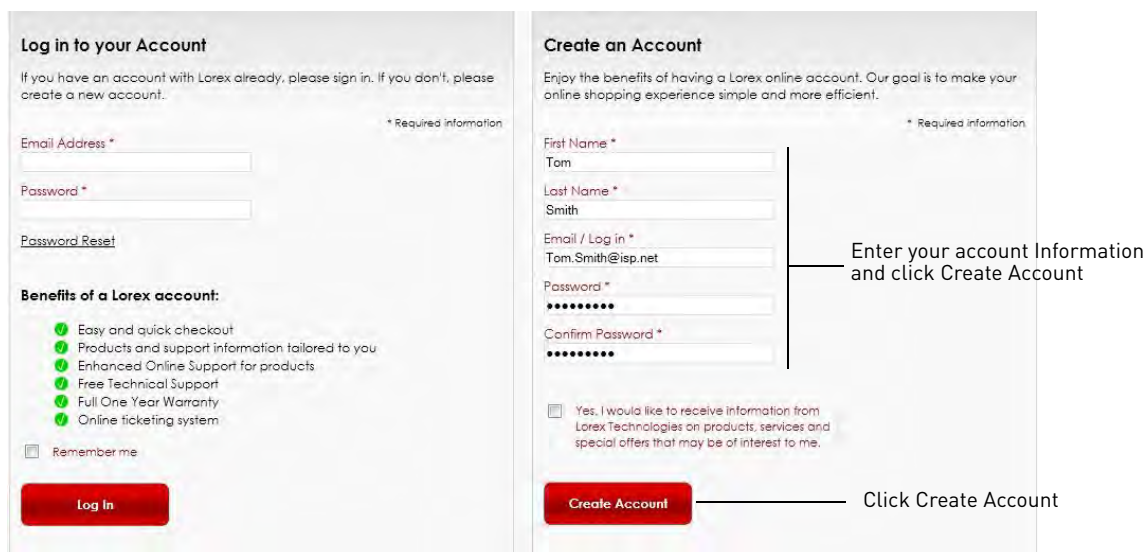

- 3 Click **Warranties** to register your product for warranty.

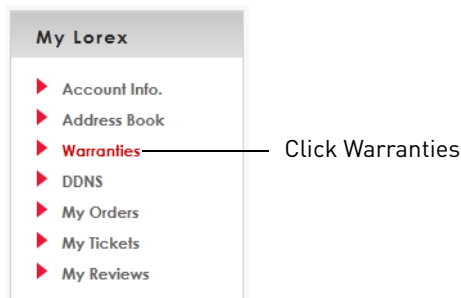

NOTE: Warranty registration is required to register for DDNS.

- 4 The Warranty page opens. Click **Activate Warranty** to register your product for warranty.

- Under **Your Address**, select an address or click **Enter a New Address** to create a new address. Fill in your address information and click **Create Address**.

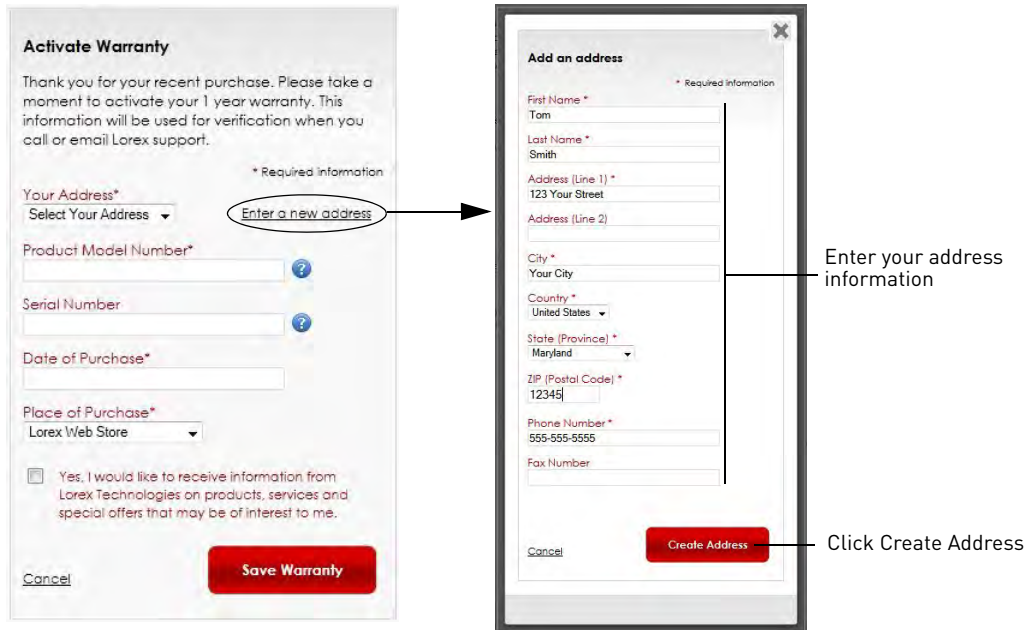

- Fill in the warranty registration form with your product and purchase details. Check the sticker underneath your DVR for the Product Model Number and Serial Number. Click **Save Warranty**.

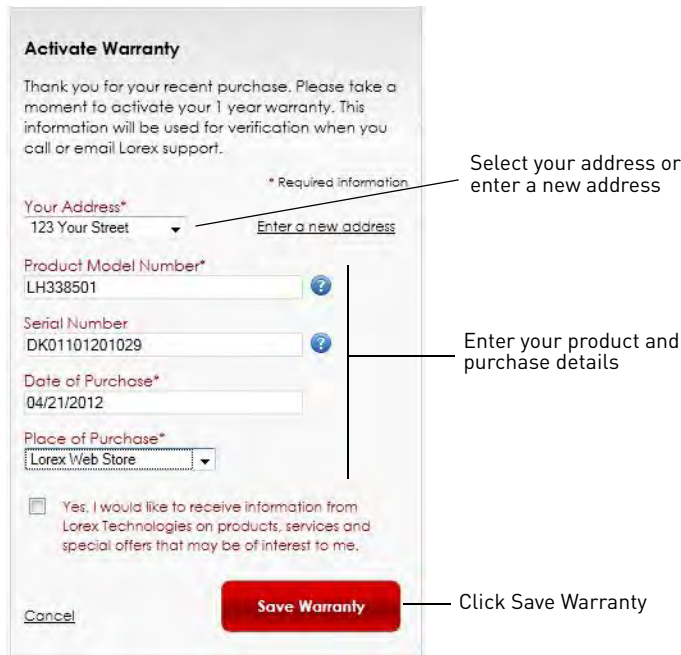

- 7 A page pops up to prompt you to register your product for Lorex DDNS. Click **Set Up a New DDNS**.

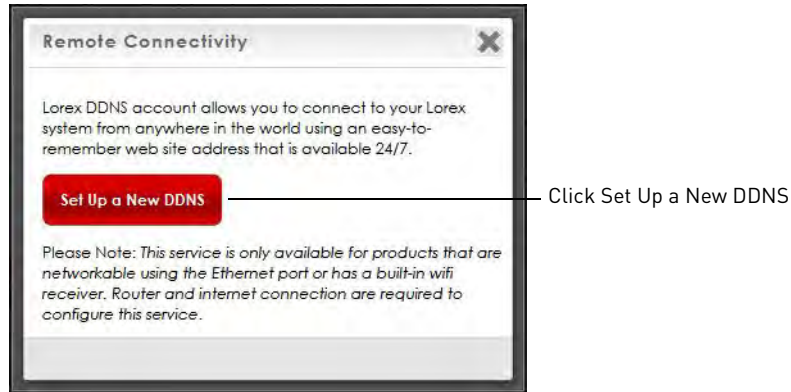

- 8 Configure the following:

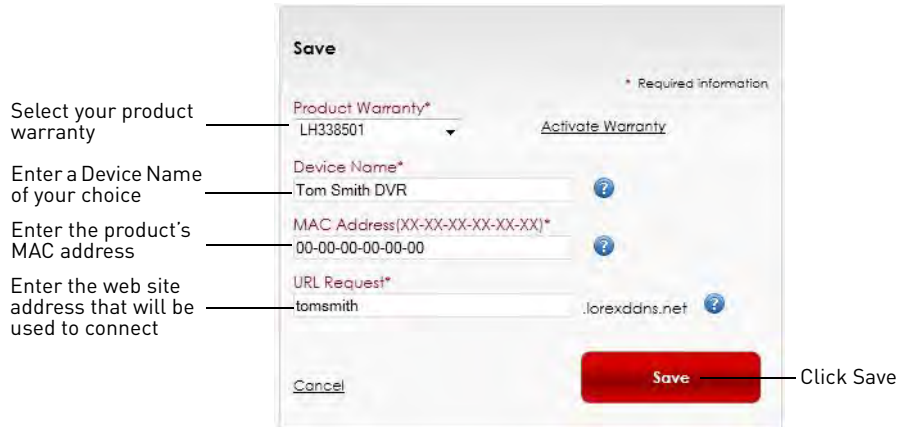

- **Product Warranty:** Select the product warranty you created in the previous steps.
- **Device Name:** Enter a name for your device. You can enter your name, business name, or anything of your choice. This is used to identify this device in your list of activated DDNS accounts that appears anytime you visit the DDNS page.
- **MAC Address:** Enter the MAC address of your Lorex product. Press the  button on the front panel to find your MAC address. A MAC address is a permanent, unique 12-digit address used to identify a device on a network.

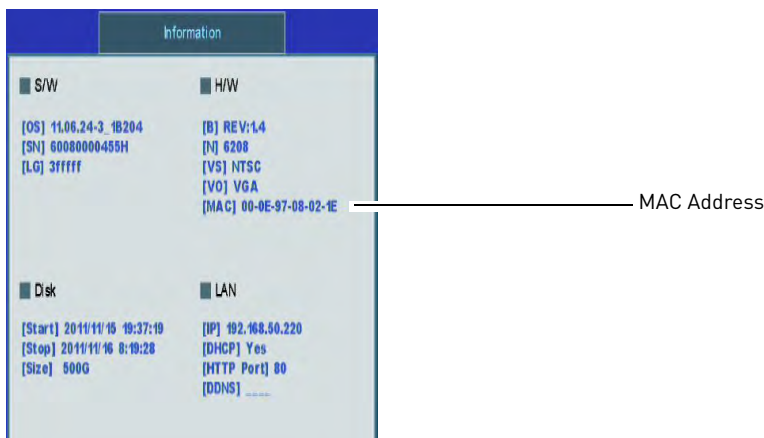

- **URL Request:** Enter the web site address that will be used to connect to your Lorex product. For example, if you enter *tomsmith*, the address to access your video will be *tomsmith.lorexddns.net* using Client Software or *http://tomsmith.lorexddns.net* using a compatible web browser.
- 9 Click **Save** to register your product for DDNS. A confirmation email will be sent to the email address used to register for My Lorex.
You will need this information to enable remote access to your system. Record your information below:

Domain name/URL Request: _____
 DDNS User Name: _____
 DDNS Device Password: _____

Step 3 of 4: Enable DDNS on the DVR

Once you have registered for free DDNS service, use the information in the confirmation email to configure DDNS settings on your system.

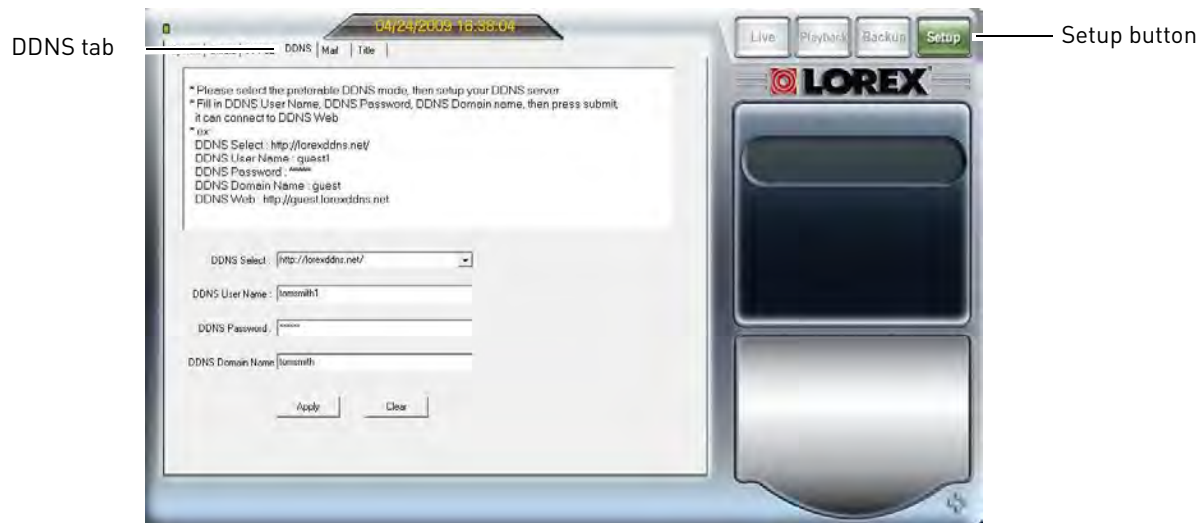

ATTENTION: You *MUST* enter your DDNS information *over the local network* before attempting remote access.

To enable DDNS on your system:

- 1 Open the Client Software and sign into your DVR.
- 2 Click the **Setup** button.
- 3 Open the **DDNS** tab.
- 4 Under DDNS Select, select **http://lorexddns.net** from the drop-down.

- 5 Configure the following:
 - **DDNS User Name:** Enter the **DDNS User Name** from the confirmation email that was sent to you after you created your DDNS account.
 - **DDNS Password:** Enter the **DDNS Device Password** from the confirmation email.
 - **DDNS Domain Name:** Enter the **Domain name/URL Request** from the confirmation email.
- 6 Click **Apply** to save your changes.
- 7 Reset the DVR by disconnecting and reconnecting the power cable from the rear panel.
NOTE: Please allow 10~15 minutes for the DDNS servers to update with your new DDNS address before attempting to connect.



Step 4 of 4: Update the Client Software with your DDNS Information

Finally, you must configure your DVR List with the DDNS information for your DVR by adding a new DVR entry to the DVR List with your DDNS address. **You will use the DDNS address whenever you want to connect to your DVR over the Internet.**

If you are performing the steps below on a computer on the same network as your DVR, this allows you to keep a separate entry for your DVR on the local network. Connecting to the DVR will be faster on the local network and will allow you to save bandwidth.

To add a new entry to your DVR list using the DDNS address:

- 1 Open the Client Software and click **DVR List**. The DVR List window opens.
- 2 Click **Add**.
- 3 Configure the following:
 - **Name:** Enter the name you would like to use for your DVR. You can use your name, your company or business name, or anything of your choice.
 - **IP/DDNS:** Enter the **Domain name/URL Request** followed by **.lorexddns.net**. For example, if the Domain name/URL request is *tomsmith*, enter *tomsmith.lorexddns.net*.
 - **Port:** Enter the **HTTP port** (default: **80**) from the System Information window.
 - **ID:** Enter the **ADMIN ID** for remote viewing (default: **9**).
 - **Password:** Enter the **ADMIN password** for remote viewing (default: **3333**).
- 4 Click **Change** to save your settings. Then click **Close** to return to the client window.
- 5 Select your DVR's DDNS address from the drop-down menu (e.g. *tomsmith.lorexddns.net*) at the top of the screen and click  to connect. Live video from your cameras will appear when the connection is successful.

NOTE: If it does not connect within 30 seconds, click  and click  again to refresh the connection.

Congratulations! Your DVR is now connected to the Internet. For instructions on using the Client Software to view live video, playback and backup recorded footage, and configure your DVR, see "PC and Mac Client Software for Remote Viewing" on page 62.

You can now access your DVR using a compatible web browser (for details, see "DVR Netviewer: Viewing Your DVR Using a Web Browser" on page 76) or mobile device (for details, see "Mobile Apps: Accessing your DVR Using a Mobile Device" on page 85).

Advanced Networking Configuration (Optional)

The following steps are recommended to ensure your DVR is secure and accessible at all times, even in the event of a power failure. Please note that some of the steps below require you to reconfigure the settings for your DVR in the Client Software.

- **Assign a fixed IP address to your DVR.** A fixed IP address will allow your DVR to keep the same IP address in the event of a power failure or if you restart your router. If your DVR's IP address changes, you may lose your port forwarding rules. See "Appendix B: Assigning a Fixed IP to your DVR" on page 104.
- **Change your system passwords** and remote access passwords to something other than the defaults. See "Managing Passwords" on page 28. If you change your remote access passwords, you must update your DVR List in the Client Software to use the new password(s).
- **Change your HTTP Port** to *any desired port* other than port 80. The port must not be blocked by your Internet service provider. For details, see "Changing the HTTP Port" on page 46. If you change your HTTP port, port forward the newly selected port and update your DVR List in the Client Software for the newly selected port.
- **Connect your DVR, router/modem, and cameras to an Uninterruptible Power Supply (UPS).** A UPS has an internal battery that will keep your equipment running in the event of a power failure. The amount of time that a UPS can keep your equipment running will depend on the model of UPS and the devices connected.

NOTE: In order to maintain remote connectivity to your DVR during a power failure, you must also connect your router and modem to the UPS.

PC and Mac Client Software for Remote Viewing

Client Software is available that allows you to access your system from any PC or Mac with an Internet connection. The Client Software is compatible with any Edge Series DVR, and it can save the device information for multiple DVRs. This means you can easily switch between multiple DVRs located in your home, business, or properties without having to re-enter the address or password.

NOTE: This section assumes that you have completed all the steps in the previous section to enable your DVR for remote viewing.

NOTE: Check www.lorextechnology.com for software updates.

Network User Accounts

In order to login to the DVR remotely, you need a Remote Access user ID and password. See the table on the right for the default Remote Access user IDs and passwords. For a detailed description of user accounts, see "User Accounts" on page 28.

Remote/LAN Access:

| Level | User ID | Password |
|-------|---------|----------|
| USER1 | 7 | 1111 |
| USER2 | 8 | 2222 |
| ADMIN | 9 | 3333 |

Running the Client Software

NOTE: For installation instructions, see "Step 3 of 4: Install the Client Software on your PC or Mac" on page 53.



- (PC) Double-click the **Lorex Client 12 icon** () on the desktop. If a security warning appears, click **Yes**. The client window opens.
- (Mac) Double-click **Edge Client Software** in your Applications folder. The client window appears.

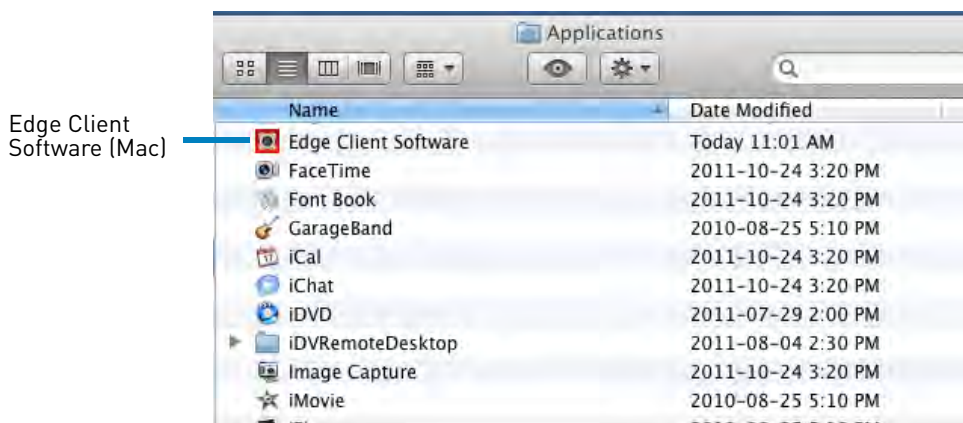

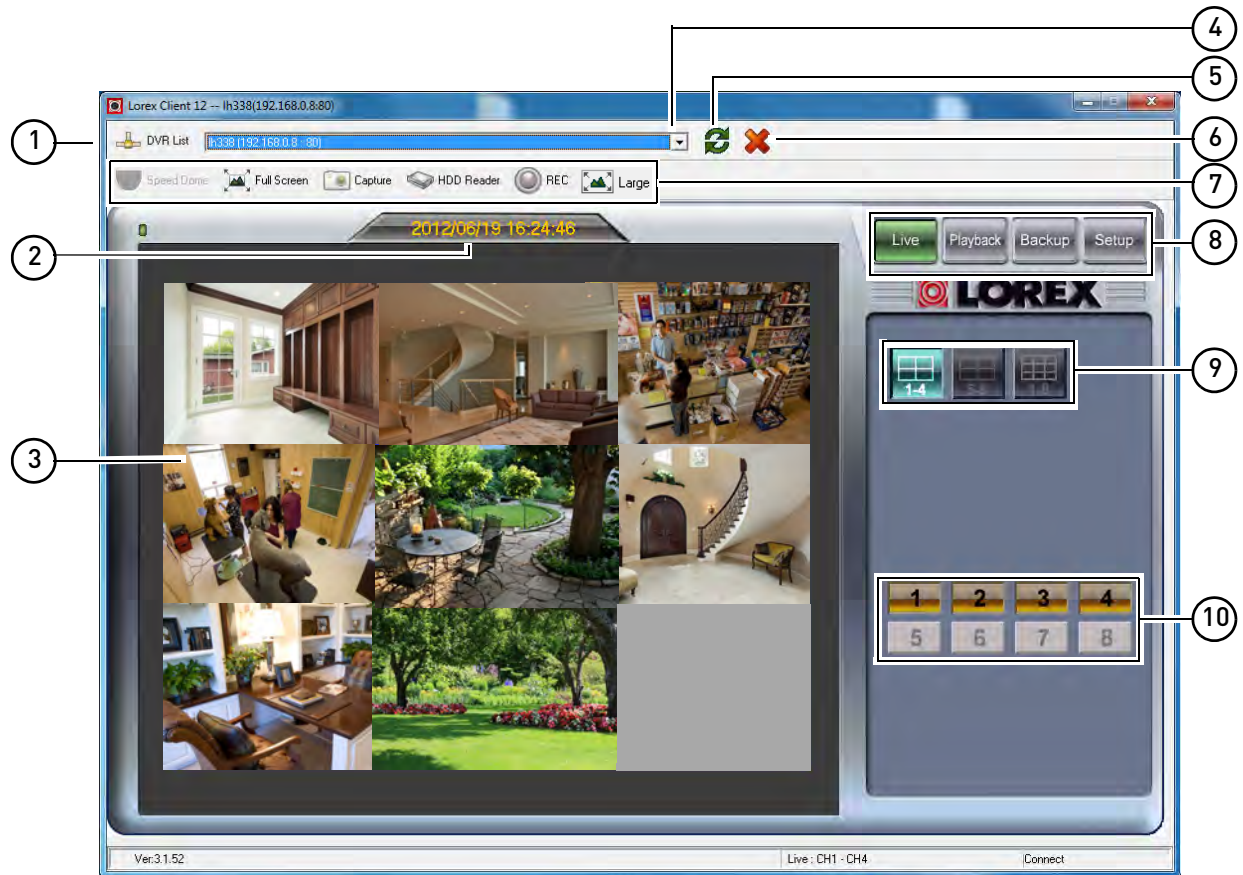

Client Window



Client Window (PC version / 8-channel model shown)

NOTE: The appearance of the client window differs before you connect to your DVR.

- 1 **DVR List:** Click to configure the connection information for your DVRs. Can save multiple Edge Series DVRs for quick access.
- 2 **Status Bar:** Shows connection status. When connected to DVR, presents the date and time on the connected DVR.
- 3 **Display screen:** Displays video from your cameras.
- 4 **DVR Selector:** Select DVRs from your DVR list.
- 5 **Connect/Refresh** : Click to connect to DVR.
- 6 **Disconnect** : Click to disconnect from your DVR.
- 7 **Utilities:** Only available on the PC version; not available on Mac or via browser. Items are grayed out when they are not currently available.
 - **Speed Dome:** Click to access PTZ camera controls when PTZ camera is selected.
 - **Full Screen:** Click to view the display screen in full-screen. Press **ESC** to exit full-screen.

- **Capture:** Click to take a screenshot of the display screen.
- **HDD Reader:** Click to playback / backup video from an external hard drive (not included) connected to the computer using a USB cable (not included). This allows you to quickly backup long segments of video, such as hours or days.
- **REC:** Click to record live video onto your computer hard drive.
- **Large:** Click to stretch the video to the edge of the gray area. Click **Small** to show the video in its original proportions.

8 Modes:

- **Live:** Click to view live, streaming video; view cameras in full-screen or split-screen.
- **Playback:** Click to view recorded video from the system.
- **Backup:** Click to save recorded video data to your computer.
- **Setup:** Click to open Setup Mode.

9 **Views:** Click to view in Quad, 9-split, or 16-split (16-split available on 16-channel only).

10 **Channels:** Click to view channels in full-screen.

DVR List: Managing DVRs

DVR List is used to save the connectivity information for your DVR or DVRs. You can use it to add a new DVR or modify or delete an existing DVR.

You can also have multiple entries in your DVR List for the same DVR. For example, on computers on the same network as your DVR, you can have one entry for the local IP address of your DVR and one entry for the DDNS address of your DVR. This can be useful if you have a laptop. When you are at home, you can view the DVR using the local IP address, which saves bandwidth and provides a faster connection. When you are out, you can connect over the Internet using the DDNS address.

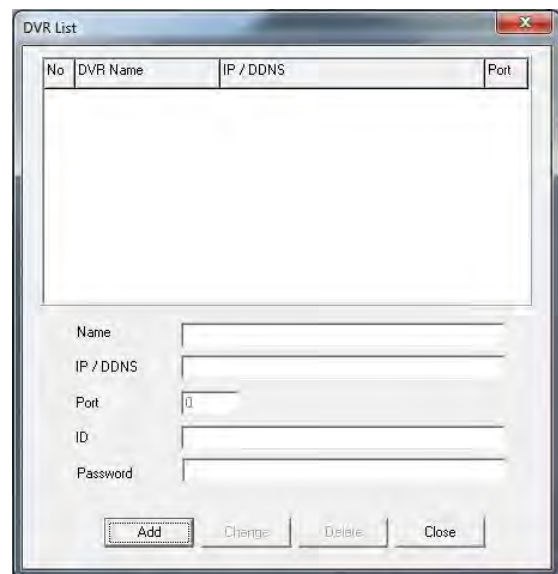



DVR List

Adding a DVR

- 1 From the Client window, click **DVR List**. The DVR List appears.
- 2 Click **Add**.
- 3 Configure the following:

- **Name:** Enter the name you would like to use for your DVR. You can use your name, your company or business name, or anything of your choice.
- **IP / DDNS:** Enter the DDNS address or IP address of your DVR. For the DDNS address, enter the **Domain name/URL Request** sent to you in the confirmation email, followed by **.lorexddns.net** (for example, *tomsmith.lorexddns.net*)
- **Port:** Enter the HTTP port (default: **80**) for your DVR.
- **ID:** Enter a user ID for remote viewing.
- **Password:** Enter the corresponding password for remote viewing.

- 4 Click **Change**. Then click **Close** to return to the client window.
- 5 To test your settings, select your DVR from the drop-down menu at the top of the screen and click  to connect. Live video from your cameras will appear when the connection is successful.

NOTE: If it does not connect within 30 seconds, click  and click  again to refresh the connection.

Changing DVR Settings

Change the settings for an existing DVR. You will need to do this if you change the passwords or port configuration of your DVR.

To change settings for an existing DVR:

- 1 From the Client window, click **DVR List**. The DVR List window opens.
- 2 Click the DVR you would like to change.
- 3 Change the configuration as needed.
- 4 Click **Change** to save your changes. Then click **Close** to return to the client window.

Click DVR
to select

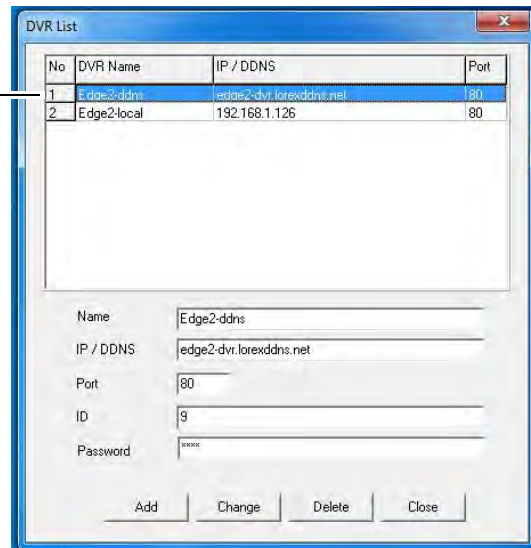



Deleting a DVR

- 1 From the Client window, click **DVR List**. The DVR List window opens.
- 2 Click the DVR you would like to delete.
- 3 Click **Delete**. Then click **Yes** to confirm.
- 4 Click **Close** to return to the client window.

Live Viewing Mode

By default, the Client Software launches in Live Viewing mode.

To use Live Viewing:

- 1 Click .
- 2 Click the **View buttons** (for example, ) to view in Quad, 9-way split, or 16-way split (16-way split available on 16-channel only).
- 3 Click the **Channel buttons** to view channels in full-screen.

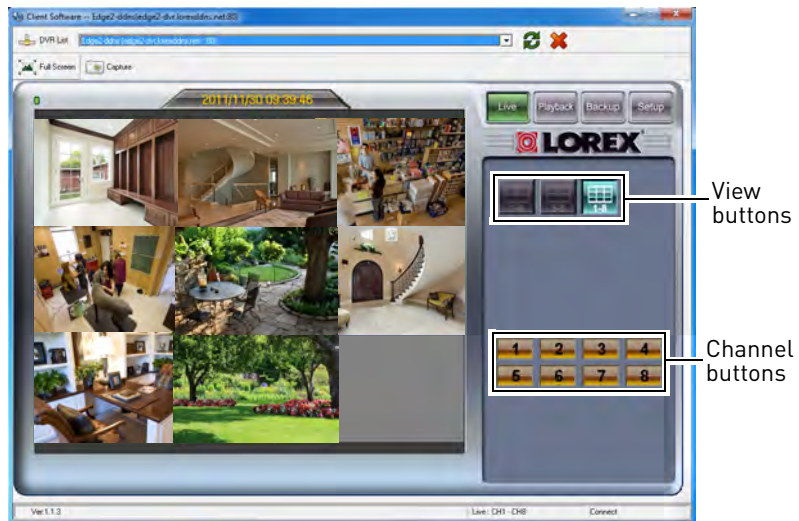

8-channel model shown







NOTE: Audio is not available in Live Viewing.

Playback Mode

Use the Playback mode to view recorded video from your DVR. Use the Pop-up Calendar to select recorded video from a specific date and time.

NOTE: Only the ADMIN and USER2 accounts may access Playback mode.

To use remote playback:



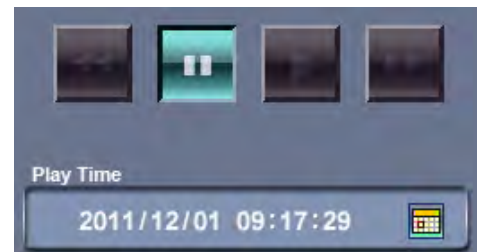

- 1 Click .
- 2 Click the **Channel buttons** to select the channel you want to view.
- 3 Click  to open the Pop-up Calendar to select the date and time.
- 4 Click , , ,  to control playback.

NOTE: When a channel with audio is selected, click  to mute / un-mute audio. Audio-enabled camera (not included) or self-powered (not included) microphone must be connected and configured. For details, see "Appendix D: Recording and Playing Audio" on page 111.



Playback controls

Using the Pop-Up Calendar

- 1 Click  to open the Pop-up Calendar to select the date and time.
- 2 Click ◀ ▶ to change the month.
- 3 Click to select a date.
- 4 Click ▲ ▼ to set the time or drag the slider to adjust time in 30 minute increments.
- 5 Click **SET**. The pop-up calendar closes.
- 6 Click , , ,  to control playback.



Drag slider to adjust time

Pop-Up Calendar

Backup Mode

Use Backup mode to copy recorded video data from your DVR to your PC or Mac.

NOTE: Only the ADMIN and USER2 accounts may use Backup mode.

NOTE: If you are accessing your DVR using a browser, you may be prompted to install the ActiveX plug-in before Backup will function properly. When prompted, click the bar to install ActiveX to your browser. DVR Netviewer will reset. You may need to log in again with your user ID and password.

To use Backup:

- 1 Click the  button.
- 2 Click the **Channel buttons** to select the channel you want to back up.

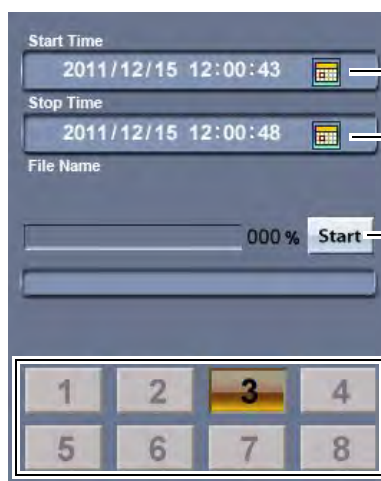

Set Start Time

Set Stop Time

Start Backup

Select Channel for Backup

Backup controls

3 Under Start Time, click  to open the pop-up calendar and select a date and time. Click the **SET** button.

4 Under Stop Time, click  to open the pop-up calendar and select a date and time. Click the **SET** button.

5 Click **Start** to begin backup. It may take several minutes to complete the backup, depending on the length of video selected. The file is saved to:

- **PC - Client Software or Browser:**
C:\DVR_Backup
- **Mac:** HD→Applications→Edge Client Software→DVR_Backup

NOTE: Backup files carry the file extension .mov. You can use QuickTime Player to view back up video files.

NOTE: If an error message appears while trying to create a backup through your web browser, close the browser. Then, right-click on the browser desktop or Start Menu icon and select **Run as administrator**. If a security warning appears, click **Yes**. Re-connect to your DVR. You should now be able to create backups as normal.

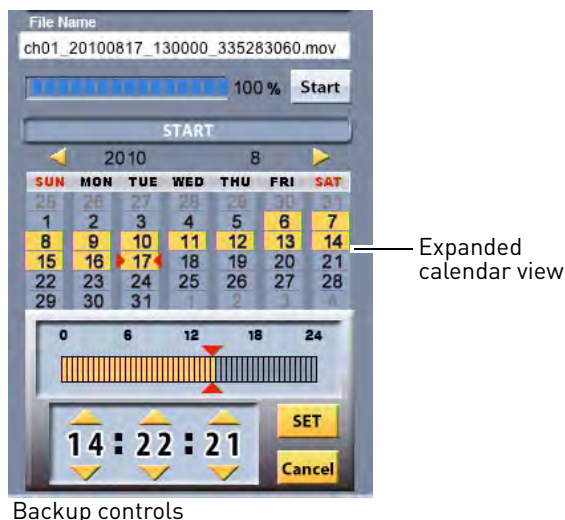

Backup controls

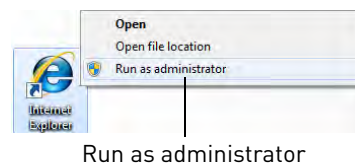

Run as administrator

Setup Mode

Use Setup Mode to configure your network settings and video streaming options. You can also use Setup mode to create custom names for your cameras.

NOTE: Only the ADMIN account can access Setup mode.



System tab in Setup Mode

To open Setup Mode:

- From the main screen, click . By default, the System tab opens.

Changing Bitrate Speed

- 1 Click the **Bitrate** tab from Setup Mode.
- 2 Under Bitrate, select a **bitrate speed**. A higher bitrate speed improves the quality of the video stream but requires more bandwidth. If the video is taking a long time to update or is choppy, it is recommended to select a lower bitrate.
- 3 Click **Apply** to save your settings to the system.

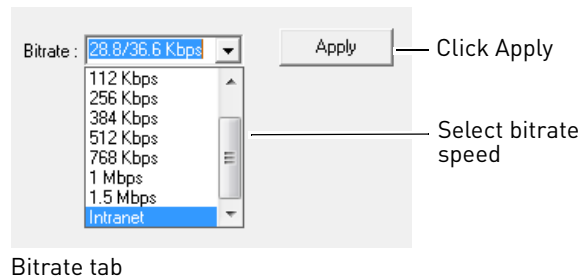

Bitrate tab

Enabling PPPoE

- 1 Click the **PPPoE** tab from Setup Mode.
- 2 Under the PPPoE Status, select **ON**.
- 3 In the corresponding text fields, enter your **PPPoE Username** and **password**.
- 4 Click **Apply** to save your settings.

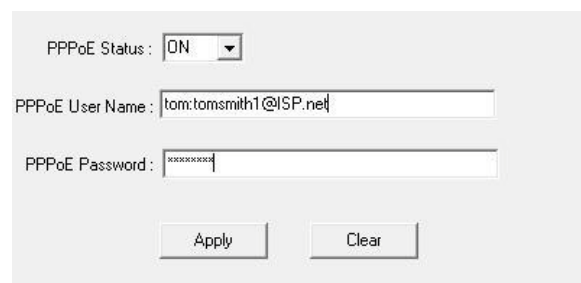

PPPoE tab

Enabling DDNS

Lorex provides a free DDNS service for use with your DVR. A DDNS account allows you to set up a permanent web-site address for your DVR.

ATTENTION: You *MUST* enter your DDNS information *on the local network* before attempting remote access.

Visit <http://www.lorexddns.net> to register for Lorex's free DDNS service. For more details on setting up a free Lorex DDNS account, see "Step 2 of 4: Create a DDNS Account" on page 55.

NOTE: You must register for Lorex's free DDNS service prior to configuring DDNS settings.

To change DDNS settings:

- 1 Click the **DDNS tab** from Setup Mode.
- 2 Under DDNS Select, click the drop-down menu and select **http://lorexddns.net**
- 3 Configure the following:
 - **DDNS User Name:** Enter the **DDNS User Name** from the confirmation email that was sent to you after you created your DDNS account.
 - **DDNS Password:** Enter the **DDNS Device Password** from the confirmation email.
 - **DDNS Domain Name:** Enter the **Domain name/URL Request** from the confirmation email.

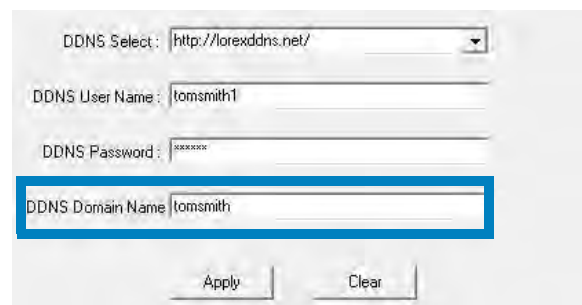

Enter only the first portion of your domain name

- 4 Click **Apply** to save your settings or click **Clear** to exit without saving.
- 5 To ensure your DDNS settings are saved on your system, disconnect the power adapter from the rear panel of your system. Allow the system to power down for 15~20 seconds. Reconnect the power adapter.

NOTE: Please allow 10~15 minutes for the DDNS servers to update with your new DDNS address. This is normal for the DDNS system.

NOTE: You will have to reconfigure your DVR's connection settings in DVR List to connect to the DVR using DDNS. For instructions, see "Changing DVR Settings" on page 65.

Viewing System Status

By default, Setup Mode opens to the System tab. However, you can view this screen at any time when navigating Setup Mode.



System tab

To view system status:

- Click the **System** tab from Setup Mode. The System Status screen appears.

NOTE: You cannot edit the IP address or port number.

Configuring Email Alerts

Use the Mail tab to configure email alerts for triggered events (such as when motion is detected by one of the cameras) on your DVR. By default, email alerts use Lorex's email server (recommended). However, you can also use your own SMTP server.

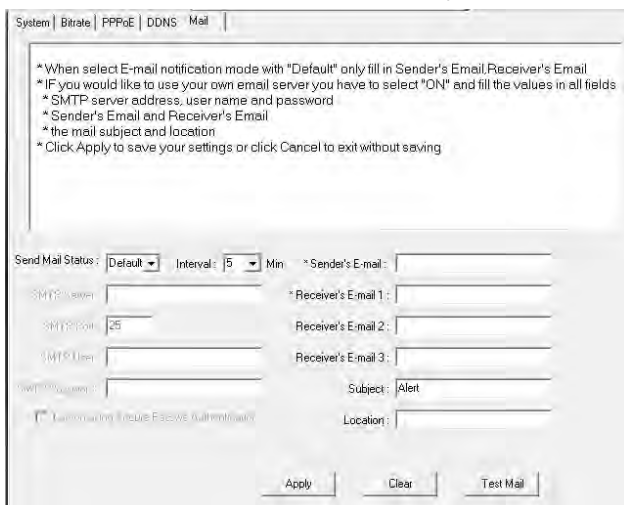

Email tab

IMPORTANT

To setup email alerts, you must be logged into your DVR using Edge Client Software. Once you are logged in, click **Setup** and then **Mail** to access the Email tab.

You must enable motion detection on your cameras to receive email alerts. For instructions, see "Enabling / Disabling Motion Detection" on page 40.

To configure email alerts:

- 1 Click the **Mail** tab from Setup Mode.
- 2 Under Send Mail Status, select **Default**.
- 3 Under the Sender's Email field, enter the **sender's email address**.

- 4 In the **Interval** drop-down menu, select the minimum interval between event notification emails. For example, if you set the interval to 5 minutes, the DVR will only send alerts every 5 minutes when an event occurs.
- 5 Under the Receiver Email fields, enter the email address or addresses you would like alerts to be sent to. You can enter up to 3 email recipients.
NOTE: You *must* enter a sender and receiver email address for email alerts to work.
- 6 (Optional) Enter a subject for the notification and a location (of the DVR) in the respective fields.
- 7 Click **Apply** to save your settings, or click **Clear** to exit without saving. Click **OK** to close the confirmation window.
- 8 Click **Test Mail** to send a test notification. Click **OK** to close the confirmation window.
NOTE: If you have made a mistake with either email addresses, you will not receive the test notification.
- 9 Restart the DVR by disconnecting the power adapter from the rear panel of the DVR and reconnect it.
NOTE: If you want to use your own SMTP server, select **ON** from the Send Mail Status drop-down menu. Enter the address of your SMTP Server, port, user name, and password. Check the Log on using secure authentication checkbox to log on using secure authentication. Enter the sender's email address and recipient's email address or addresses. Click **Apply** to save your settings and **Test Mail** to test the notification.

Creating Custom Camera Titles

Use the title tab to create custom titles for your cameras. Custom titles are displayed on the DVR but are not shown while viewing remotely. You can also save custom title configurations to your computer and restore them later or apply them to other DVRs.

To change camera names/titles:

- 1 Click the **Title** tab from Setup Mode.
- 2 Under the Channel fields, enter a new title for the camera. For example, Parking Lot 1, Front Door, etc.
- 3 (Optional) (PC) Click **Font Size** drop-down menu to change the size of your camera titles. You can also drag the slider to adjust the font size or manually enter the font size.

The screenshot shows the 'Title' tab in the DVR configuration software. At the top, there are tabs for 'System', 'Bitrate', 'PPPoE', 'DDNS', 'Mail', and 'Title'. The 'Title' tab is selected. Below the tabs, there are 'Load File' and 'Save File' buttons. A large blue box displays the current title 'Side Entrance'. Below this, there are eight channels (CH1 to CH8) with text input fields for their titles: CH1 (Parking Lot 1), CH2 (Parking Lot 2), CH3 (Reception), CH4 (Hallway 1), CH5 (Hallway 2), CH6 (Showroom), CH7 (Boardroom Hallway), and CH8 (Side Entrance). On the left side, there is a 'Font Size' section with a dropdown menu set to 'X-Large' and a numerical input field set to '100'. Below that is a 'Language' dropdown menu set to '0 English'. At the bottom left, there is an 'Apply' button.

Title tab

- (Mac) Click the **Font Option** button and use the menu to change the font and font size.
- (PC only) Use the Language drop-down menu to select the language for the camera titles.

- 4 Click **Apply** to save the new titles to your DVR.
- 5 Return to your DVR and refresh your screen by changing the display mode (single, quad, split-screen) to see the new titles.

To save a camera title configuration (PC only):

- 1 Click **Save File**.
- 2 Select a save location, enter a file name, and click **Save**.

To load a camera title configuration (PC only):

- 1 Click **Load File**.
- 2 Select the configuration file and click **Open**.
- 3 Click **Apply** to update your DVR with the saved configuration.
- 4 Return to your DVR and refresh your screen by changing the display mode (single, quad, split-screen) to see the new titles.

Taking Screenshots (PC Only)

You can use the **Capture** button to take screenshots of the display area at any time during live viewing or playback.

NOTE: Screenshot function is not available on Mac or via browser.

To take screenshots:

- 1 Click the **Capture** button ( Capture). The Capture window opens with a preview of your screenshot.
- 2 Click **Save As**. A Save As window appears. Select the folder where you would like to save the screenshot. In the File Name field, enter a name for your snapshot. Click **Save**.



NOTE: The Capture button takes a snapshot of the entire display area. To take a snapshot of a single camera, you must switch to it before clicking Capture.

Manual Recording (PC Only)

You can use the **REC** button to create a manual recording of the display area anytime during live viewing.

NOTE: Manual recording is not available on Mac or via browser.

To take a manual recording:

- 1 Click the **REC** button (). The REC button flashes to indicate manual recording is on.
- 2 Click the **REC** button again to stop recording.

NOTE: Manual recordings are saved to *C:\DVR_Backup*.

NOTE: The REC button takes a recording of the entire display area. To take a recording of a single camera, you must select it before clicking REC.

Accessing Remote Speed Dome Settings (PTZ Controls) (PC Only)



You must connect and configure PTZ cameras locally on the DVR before you can use remote PTZ controls. For instructions on connecting PTZ cameras, see "Appendix C: Connecting PTZ Cameras" on page 108.

Using the Speed Dome menu, you can control your PTZ cameras (not included) remotely.

NOTE: Remote Speed Dome settings are not available on Mac or via browser.

To access Speed Dome Settings on Client Software:

- 1 Click the channel number that the PTZ camera is connected to.



Select the channel for the PTZ camera

- 2 Click **Speed Dome**. Speed Dome controls open.

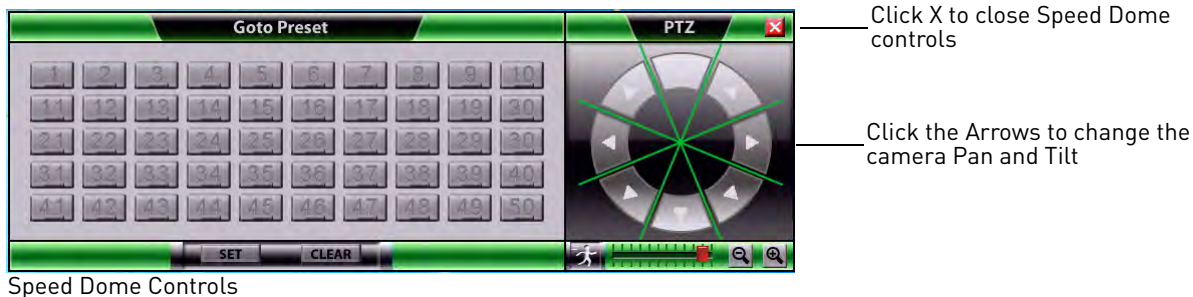

NOTE: The Speed Dome controls are identical to the controls available through the DVR. For details, see “Controlling PTZ Cameras” on page 109.

Using the HDD Reader (PC Only)

The HDD Reader is used to backup and playback video saved on an external hard drive (not included). This allows you to quickly backup long segments of video, such as hours or days. It is also useful if the DVR is damaged or removed by an intruder, and you need the video data that is stored on the external hard drive. For details on setting up an external hard drive with the DVR for HDD extension or mirroring, see “Configuring your External Hard Drive for HDD Mirroring or Extension” on page 39.

It may also be used to access the footage on your DVR’s internal hard drive when it is connected to your computer using a 3.5” SATA external hard drive enclosure (not included) using a USB cable (not included). This requires you to remove the hard drive from your DVR and install it in the external hard drive enclosure.

ATTENTION - When removing the hard drive, it is **VERY IMPORTANT** to follow the instructions in “Appendix F: Replacing the Hard Drive” on page 114 to avoid damaging your DVR.



To use the HDD Reader:

- 1 Connect the external hard drive (not included) to your computer using a USB cable (not included).

NOTE: The hard drive may not be visible if you try to locate it using Windows Explorer or My Computer. This is normal. The DVR stores data in a format that is incompatible with Windows.



- 2 Open the Client Software and click the **HDD Reader** button (). The HDD Reader opens to Playback Mode.

To playback video using the HDD Reader:

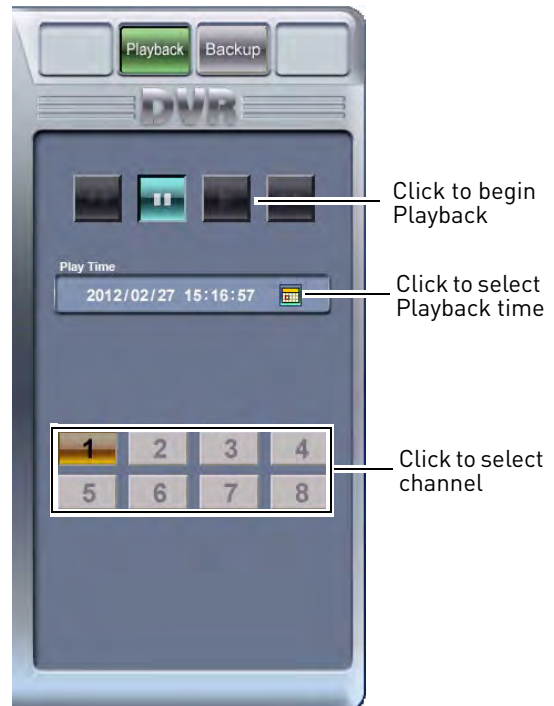
- 1 Under **Play Time**, click  and use the pop-up calendar to select a date and time to play back.
- 2 Select the channel you would like to playback and click  to begin playback.
- 3 Click  to pause playback and select another playback time.



To backup video using the HDD Reader:

- 1 Click the  button.
- 2 Under **Start Time**, click  and use the pop-up calendar to select a date and time.
- 3 Under **Stop Time**, click  and use the pop-up calendar to select a date and time.
- 4 Select the channel you would like to back up.
- 5 Click **Start** to begin the back up. Back up may take several minutes to complete, depending on the length of video specified.

NOTE: Back up files are saved to *C:\DVR_Backup*.

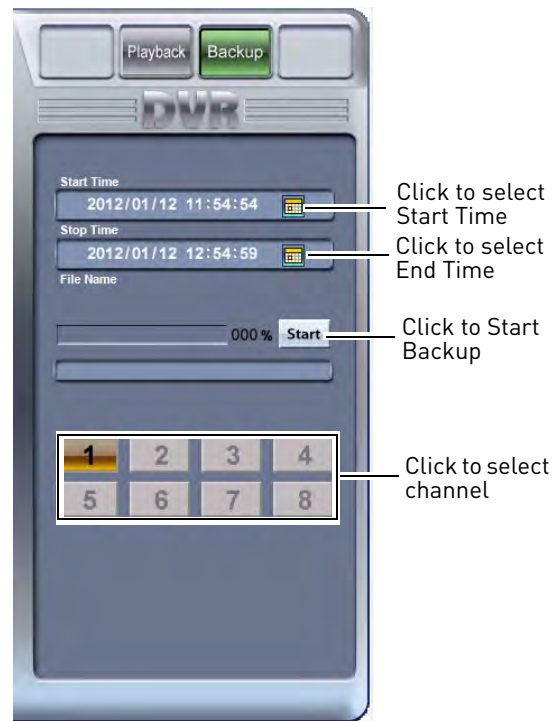

DVR Netviewer: Viewing Your DVR Using a Web Browser

DVR Netviewer is a built-in, browser based software for remotely connecting to your DVR. This section only covers how to connect to your DVR using compatible browsers. It assumes that you have completed all the steps in the section "Setting up your DVR for Remote Connectivity" on page 51 to configure your DVR for remote viewing over the Internet.

NOTE: The interface for DVR Netviewer is identical to the Client Software, except it does not support certain features, such as DVR List. For instructions on how to navigate the remote viewing interface to access and control your DVR, see "PC and Mac Client Software for Remote Viewing" on page 62.

Connecting to your DVR Using a DDNS or IP Address

When you connect to your DVR using a web browser, enter the DDNS address of your DVR. A DDNS address is a permanent, web site address that will allow you to connect to your DVR over the Internet from any compatible browser or mobile device. To connect using a DDNS address, you must register for a free Lorex DDNS account and configure your DVR with your DDNS account information. For instructions, see "Accessing your DVR Remotely Over the Internet" on page 55.

Use the following format to connect to your DVR using a DDNS address: **http://**, the **Domain Name/URL Request** you created when you made your DDNS account, followed by **.lorexddns.net**, **colon**, and the **HTTP port** number (default: **80**). See below for an example.



Example of a DDNS address



Internet Explorer connected to a DDNS address

You can also connect to the DVR using an internal or external IP address; however, it is recommended to use the DDNS address, because it is a text address that is easy to remember and will not change. **Using an internal, or local IP, address is only available on computers on the same network as your DVR.**

Use the following format to connect to your DVR using an IP address: **http://**, the IP address, and then **colon** and the **HTTP port** number (default: **80**). See below for an example.

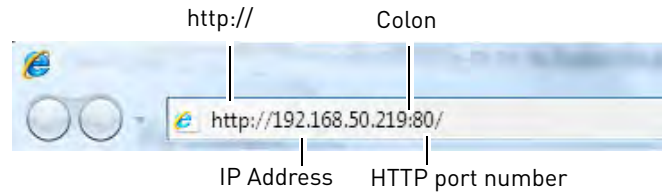

Internet Explorer connected to a local IP address

Connecting to the DVR over a LAN Using UPnP

This DVR features UPnP for easy connection over a local area network (LAN). UPnP allows a PC on the same network to automatically locate the DVR's IP address.

NOTE: The following method only works over a local network. You must complete DDNS and port forwarding setup to connect to your DVR over the Internet. For instructions, see "Accessing your DVR Remotely Over the Internet" on page 55.

To connect to your DVR on the local network using UPnP:

- 1 On a PC connected to the same router as the DVR, open Windows Explorer (**Start**→**Computer**) and click **Network**. The DVR's IP address appears.
- 2 Double-click the DVR's IP address to connect to the DVR. The DVR will open in your default browser.

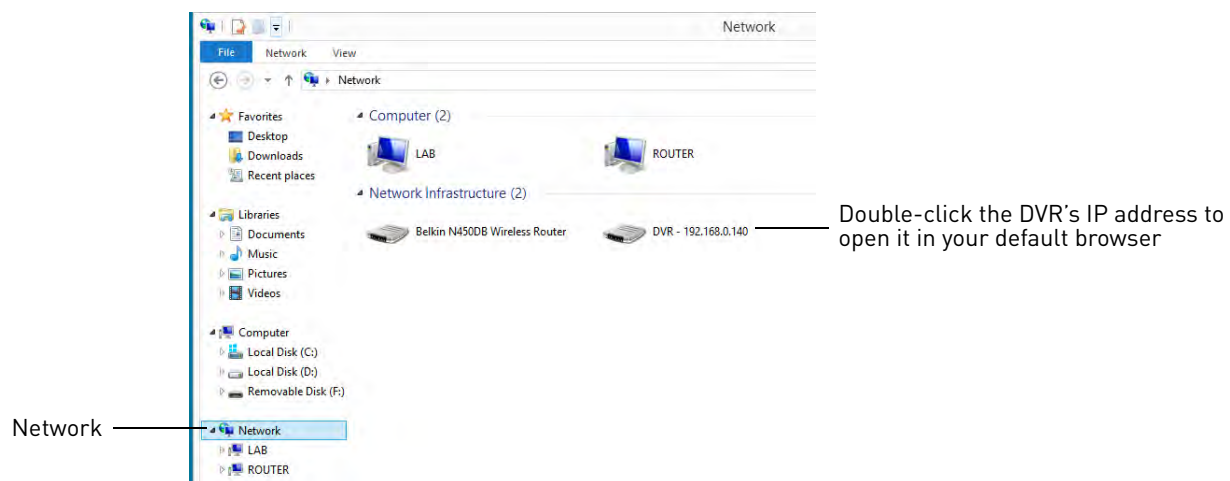

You will need to complete additional steps to connect to the DVR in your web browser. See below for details.

Internet Explorer

Remote viewing using Internet Explorer is supported on Internet Explorer versions 6 and higher. The instructions below describe how to connect to your DVR on Internet Explorer 6 through 8. See page 79 for instructions specific to Internet Explorer 9 and 10.

! You must port forward your router before you can connect to your system using a web browser (e.g. Internet Explorer)

To view your DVR using Internet Explorer:

- 1 Open Internet Explorer and enter your **DVR's DDNS address** or **IP address** in the address bar.

NOTE: When opening Internet Explorer, it is recommended to right-click the Internet Explorer icon from your Start Menu or Desktop, and select **Run as administrator**. This will allow you to use the remote back up feature to save video files from your DVR on your computer hard drive.

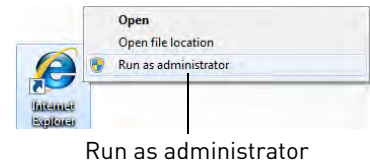

- 2 In the ID and Password fields, enter your **remote access ID** (default: **9**) and **password** (default: **3333**) and click **Login**.

- If you enter the incorrect ID or password, the login page will refresh and the fields will clear.



- 3 You must install the ActiveX[®] plug-in for DVR Netviewer to function. Click the attention bar at the top of the main page and select **Install this Add-on for All Users on This Computer...** DVR Netviewer will reset.

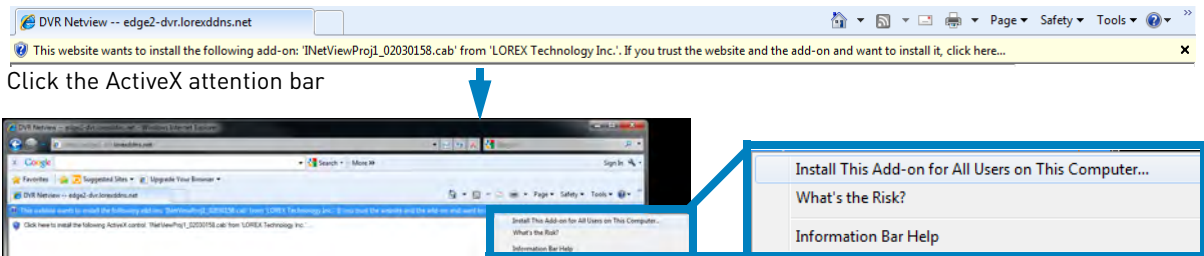

- 4 Re-enter your ID and password and click **Login**. An installation window opens.

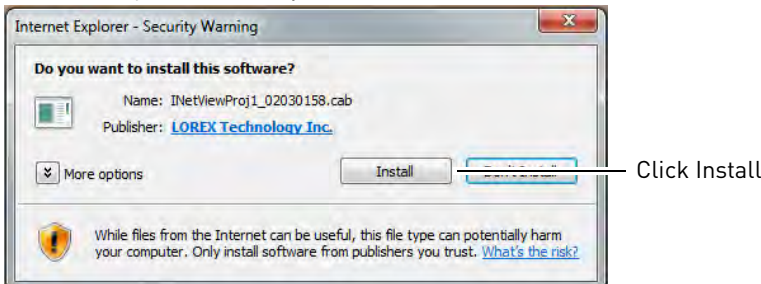

- 5 Click **Install**. DVR Netviewer launches.

Internet Explorer 9 / 10

You must use compatibility mode to connect to your DVR using Internet Explorer 9 or 10.

To view your DVR using Internet Explorer 9 or 10:

- 1 Open Internet Explorer. On Windows 8, you must use the Desktop version of Internet Explorer.

NOTE: You must use the 32-bit version of Internet Explorer. From the Start Menu, click **Internet Explorer**. Do not click Internet Explorer (64-bit).

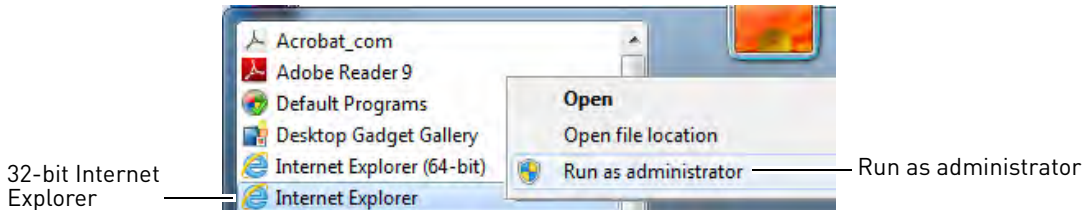

NOTE: When opening Internet Explorer, it is recommended to right-click the Internet Explorer icon, and select **Run as administrator**. This will allow you to use the remote back up feature to save video files from your DVR on your computer hard drive.

NOTE: On Windows 8, right-click the Internet Explorer taskbar icon, then right-click Internet Explorer and select **Run as Administrator**. You must run Internet Explorer from the Desktop to access your DVR.

- 2 Enter your **DVR's DDNS address or IP address** in the address bar.
- 3 In the ID and Password fields, enter your **remote access ID** (default: **9**) and **password** (default: **3333**) and click **Login**. An attention bar appears at the bottom of the screen asking if you want to install an add-on.
- An attention bar may appear at the bottom of the screen asking if you want Internet Explorer to remember the password for your DVR. Click either **Yes** or **No**, depending on your preference.

NOTE: If you see a white page with text, you will need to enable compatibility mode. Click the **broken page icon** in the address bar. The icon will turn blue.



- 4 Click **Allow** in the attention bar. The page refreshes.



- 5 Re-enter your **remote access ID** and **password** and click **Login**. Another attention bar appears.

- 6 Click **Install** in the attention bar. The page refreshes.

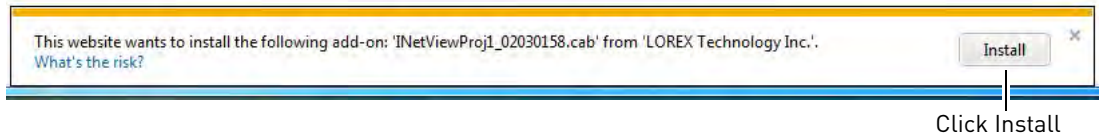

- 7 Re-enter your **remote access ID** and **password** and click **Login**. An install window appears.
- 8 Click **Install**. DVR Netviewer launches.

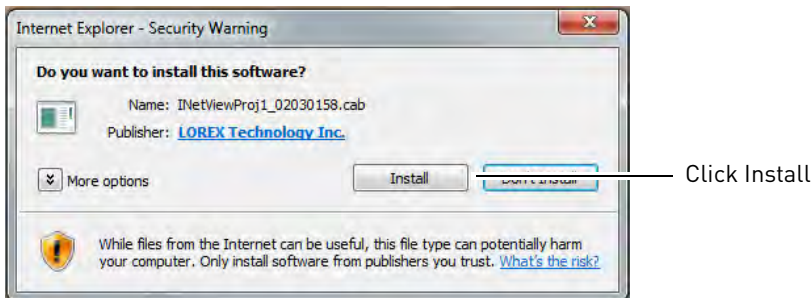

Mozilla Firefox

You must download an extension called **IE Tab** before Firefox can connect to your DVR.

NOTE: The instructions and illustrations below serve as a guideline only. Mozilla may change their browser interface without prior notice.

! You must port forward your router before you can connect to your system using a web browser (e.g. Internet Explorer)

To connect to your DVR using Firefox:

- 1 Open Firefox, and then click **Firefox→Add-ons**.

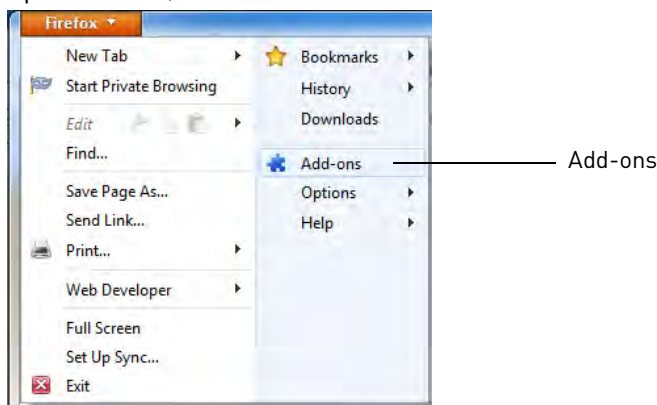

- 2 In the search bar, enter **ie tab** and then press **Enter**.

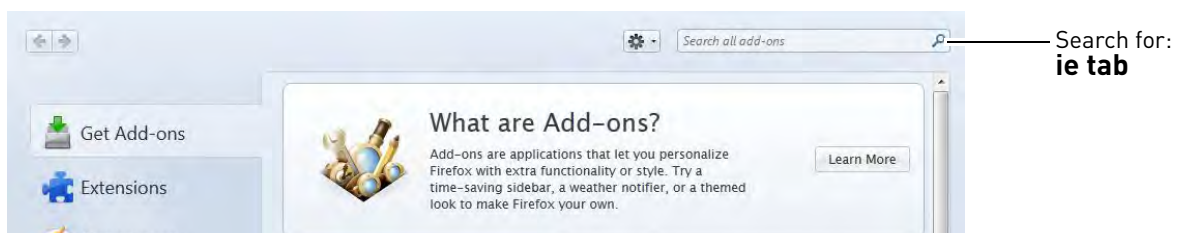

- 3 Next to the add-on called **IE Tab V2**, click **Install** to install the extension.
- 4 Click **Restart now** or restart Firefox manually.
- 5 Enter your DVR's **DDNS address** or **IP address** into the address bar.
- 6 Right-click anywhere on the page, and then click **View Page in IE Tab**. The page refreshes.

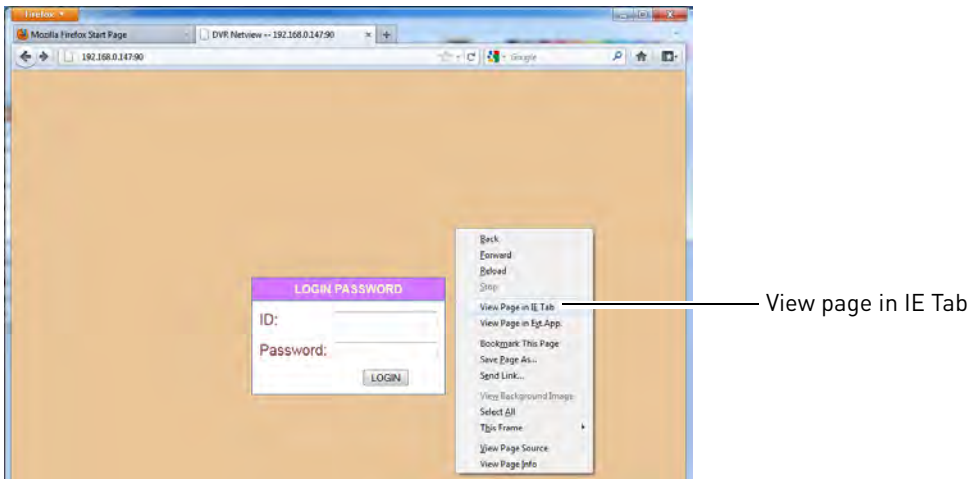

- 7 In the ID and Password fields, enter your **remote access ID** (default: **9**) and **password** (default: **3333**) and click **Login**. An install window appears.
- 8 Click **Install**. DVR Netviewer launches.

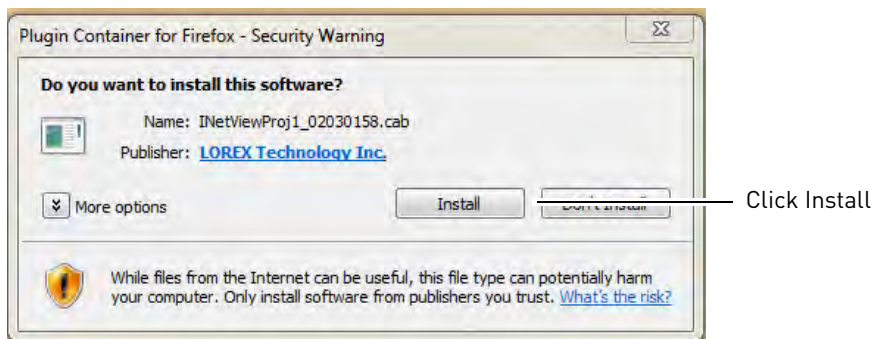

Google Chrome

You must download an extension called **IE Tab** before Chrome can connect to your DVR.

NOTE: The instructions and illustrations below serve as a guideline only. Google may change their browser interface without prior notice.

! You must port forward your router before you can connect to your system using a web browser (e.g. Google Chrome)

To connect to your DVR using Chrome:

- 1 Open the Chrome browser and then click on  → **Tools** → **Extensions**.

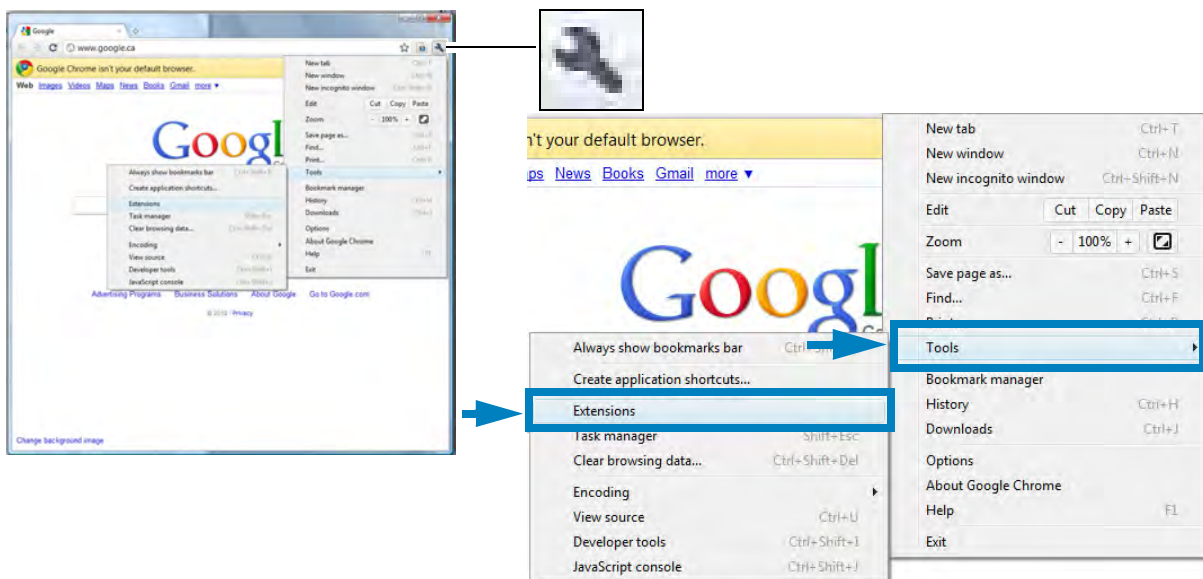

- 2 Click **browse the gallery** or **Get more Extensions**. The Chrome Web Store opens (IE Tab is a free download).

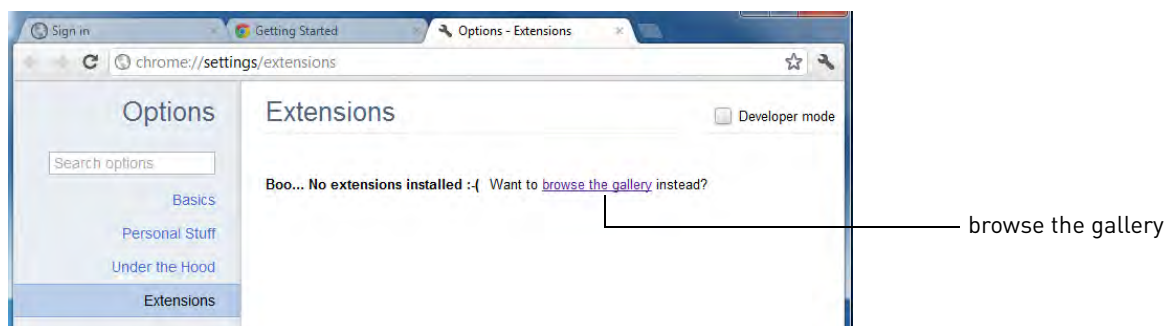

- 3 In the search field, search for **ie tab**.

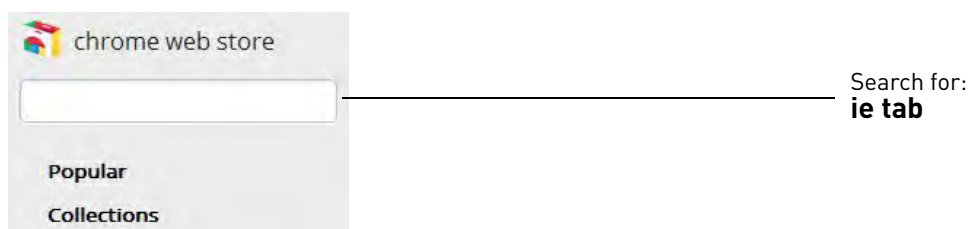

- 4 Next to IE Tab, click **Add to Chrome**, and then click **Install**.

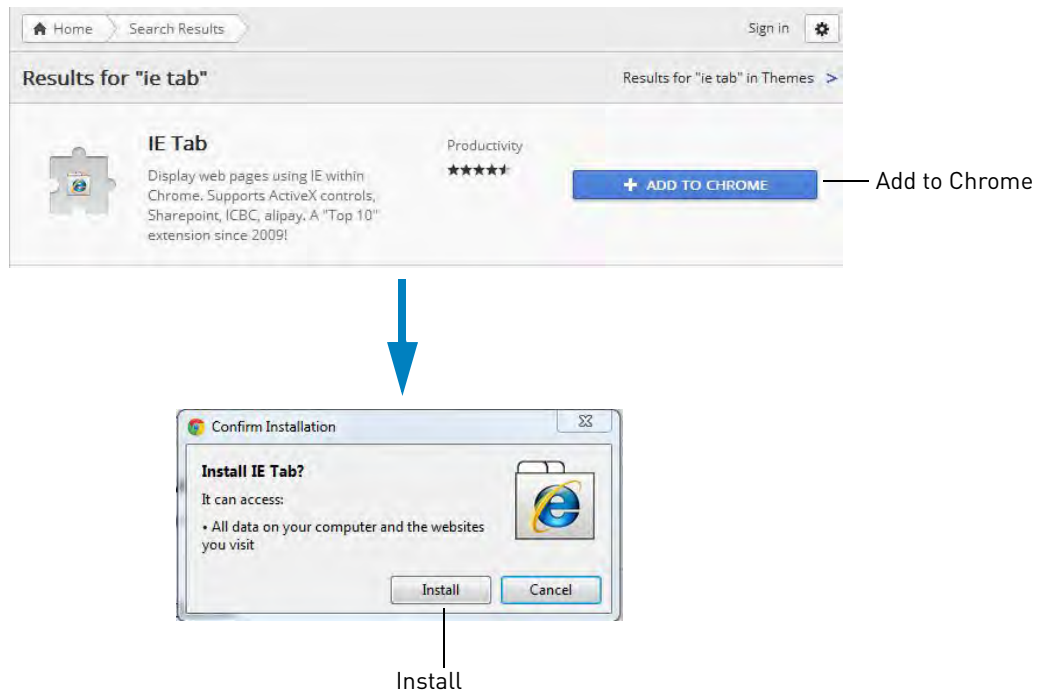

- 5 Enter your **DVR's DDNS address** or **IP address** in the address bar.

- 6 In the Chrome browser, click  to open the IE Tab extension.
- A secondary IE Tab address bar appears in the browser with the URL you typed in.

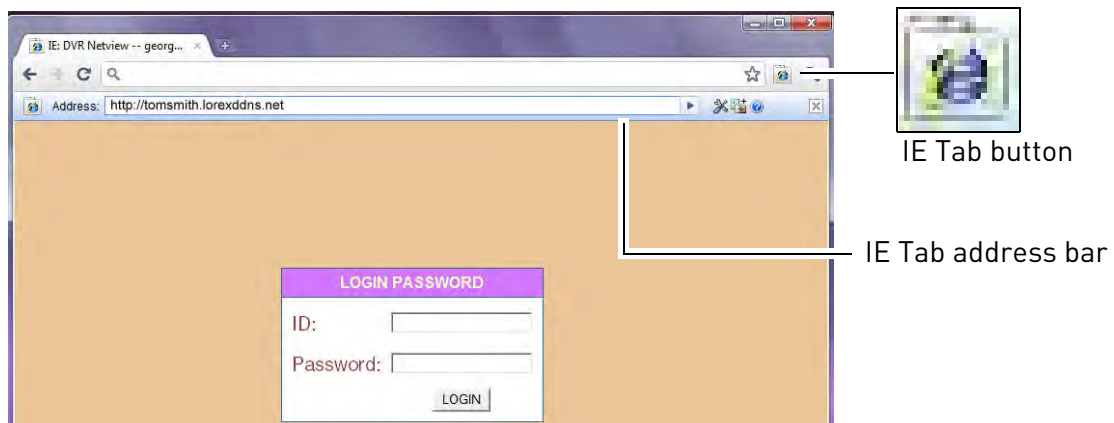

- 7 Under ID and Password, enter your **remote access ID** (default: **9**) and **password** (default: **3333**) for remote viewing and click **Login**.

- 8 You must install the ActiveX[®] plug-in for DVR Netviewer to function. Click the attention bar at the top of the main page and select **Install this Add-on for All Users on This Computer....** DVR Netviewer will reset.

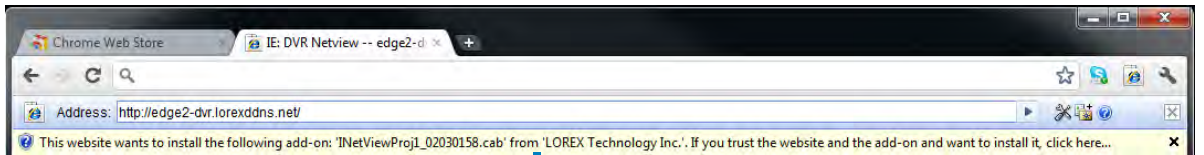

Click the attention bar

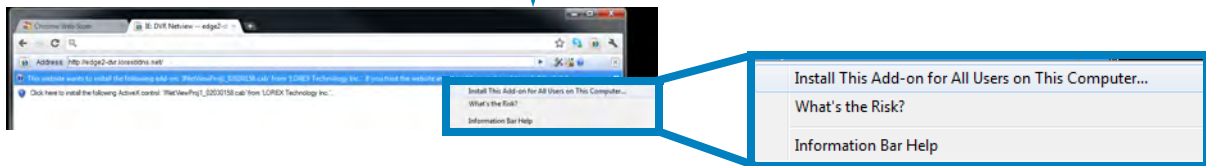

Select Install this Add-on for All Users on This Computer..

- 9 Re-enter your **remote access ID** and **password** and click **Login**. An installation window opens.

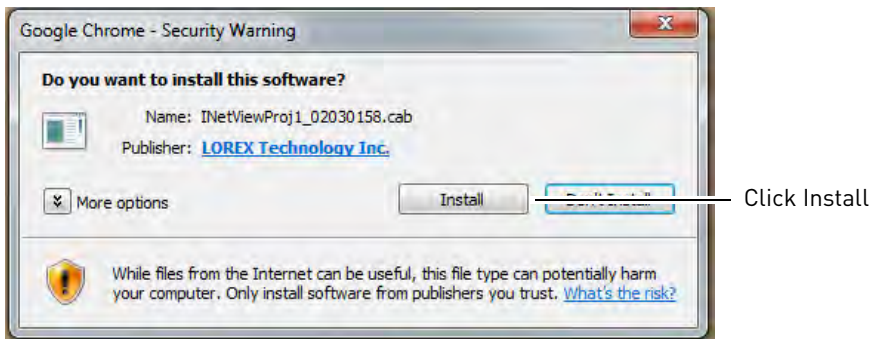

- 10 Click **Install**. DVR Netviewer connects.

Mobile Apps: Accessing your DVR Using a Mobile Device

You can remotely view camera streams from your DVR on compatible mobile phones and tablets.

NOTE: Port forwarding and DDNS registration are required before you can connect to the DVR using a mobile device. Different features are available on each mobile viewing device and application.

Compatible Devices and Platforms

| Platform | Supported Versions and Devices | App Name | Get App From |
|------------|---|--|--|
| iOS | iOS v. 4.0 and higher iPhone/iPod Touch iPad (1st generation and above) | Lorex Live (iPhone/iPod Touch) Lorex Live Plus (iPad) | Apple App Store |
| Android | Android v. 2.1 | Lorex Mobile Edge | Google Play Store |
| BlackBerry | 8900, 9000, 9700, 9800 | Lorex Mobile View | www.lorexttechnology.com |

For the latest device compatibility list, visit www.lorexttechnology.com

Before You Begin

You will need the following before you can start viewing on your mobile device:

- **Your DVR's DDNS address:**

Before you can connect with a mobile device, you must complete the setup process for remote viewing to obtain your DDNS address and enable DDNS on your DVR. Complete all the steps under "Setting up your DVR for Remote Connectivity" on page 51.

- **The HTTP Port Number of your DVR:**

The HTTP Port (default: **80**) must be port forwarded to your DVR's IP address before you can connect using a mobile device. For details on port forwarding, see the Easy Connect manual on the CD or the reference guides on www.lorexttechnology.com. To find your HTTP port, press  on the front panel of the DVR to open the System Information window and look under HTTP Port.

- **The remote user ID and password of your DVR:**

See the table on the right for the default remote access passwords.

Remote/LAN Access

| LEVEL | ID | PASSWORD |
|-------|----|----------|
| USER1 | 7 | 1111 |
| USER2 | 8 | 2222 |
| ADMIN | 9 | 3333 |

iPhone / iPad App

iPhone Users

To connect to your DVR using the iPhone, you need to download and install the **Lorex Live** application from the App Store.

iPad Users

To connect to your DVR using the iPad, you need to download and install the **Lorex Live Plus** application from the App Store.

NOTE: Lorex Live and Lore Live Plus are free, but you will need to create an iTunes account to download Apps from the Apple App store. A valid credit card is required to create an iTunes account.



You must port forward your router before you can connect to your system using a mobile device (e.g. iPhone/iPad)

Downloading the Lorex Live Application on iPhone / iPad

- Download **Lorex Live** (for iPhone) or **Lorex Live Plus** (for iPad) from the App Store.

NOTE: For support on downloading or installing iPhone/iPad apps, consult your iPhone/iPad user's manual or www.apple.com for support.

Connecting To Your DVR on the iPhone

- 1 Touch the Lorex Live icon (). The DVR Setup screen appears.
- 2 Under DVR NAME, enter a name for your DVR. This can be anything you want (Home, Office, etc.).
- 3 Under IP / DDNS, enter the **DVR's DDNS address** in full (e.g. *tomsmith.lorexddns.net*)¹.
- 4 Under PORT, enter the **HTTP Port** (default: **80**).
- 5 Under ID and Password, enter the **Remote Access user ID** (default: **9**) and **Password** (default: **3333**) for the DVR.
- 6 Touch the **Connect** button at the top-right corner of the screen.
 - If you are asked if you want to save changes, touch **YES** to save your DVR's information in the Address Book or **NO** to connect without saving your DVR's information.
- 7 The iPhone connects to your DVR and displays streaming video. Please allow a few seconds for the connection to establish. To disconnect from your DVR, touch **Log Out**.



DVR Setup screen on iPhone

1. Some routers may prevent you from connecting to your DVR using a DDNS address on a local network. If you are unable to connect, try disabling WiFi on your mobile device and attempt to connect using the 3G or mobile network. If you need to use WiFi, use the DVR's internal IP address to connect.

The Lorex Live Interface

The Lorex Live interface allows you to view a single camera in windowed (portrait) or full-screen (landscape) view, switch between connected cameras, and playback recorded video.

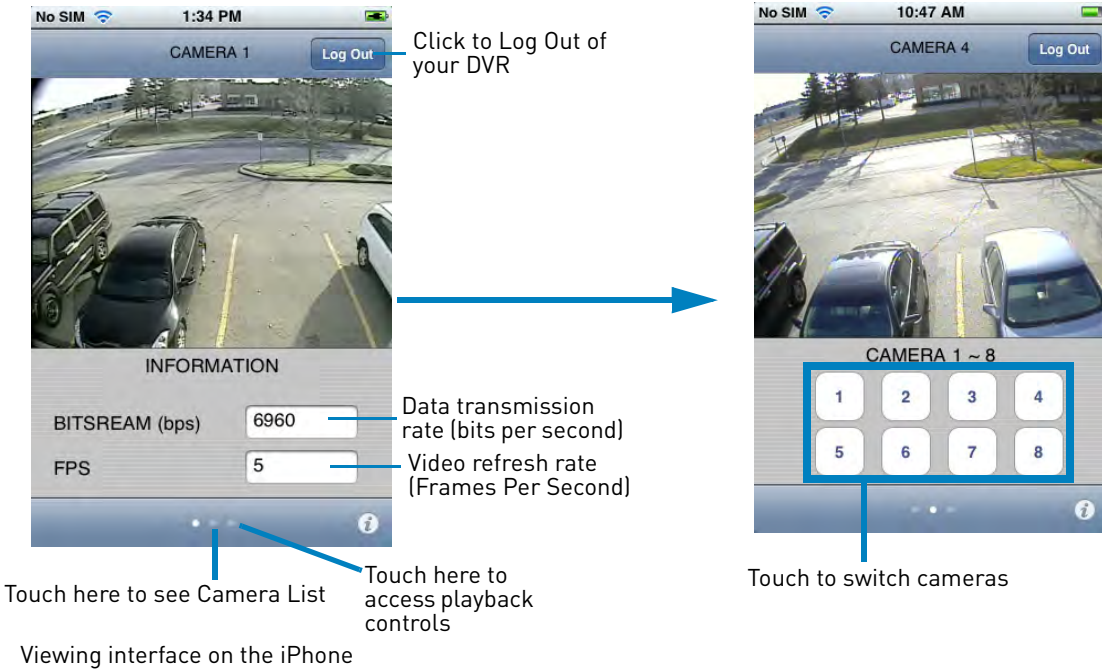

To switch cameras on the iPhone:

- 1 Touch the middle button at the bottom of the screen to access the Camera List.
- 2 Touch the number of the camera you would like to switch to.

To view cameras in full-screen:

- Touch anywhere inside the display area. The camera view changes to full-screen. The view also rotates to landscape mode. Swipe left and right to change cameras. Touch again to exit full-screen.

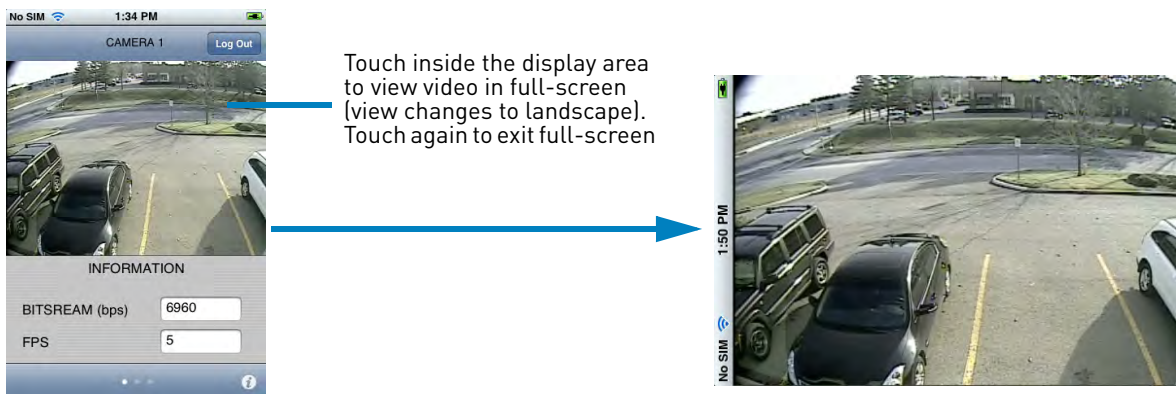

To playback recorded video on the iPhone:

- 1 Touch the right button at the bottom of the screen to access Playback Controls.

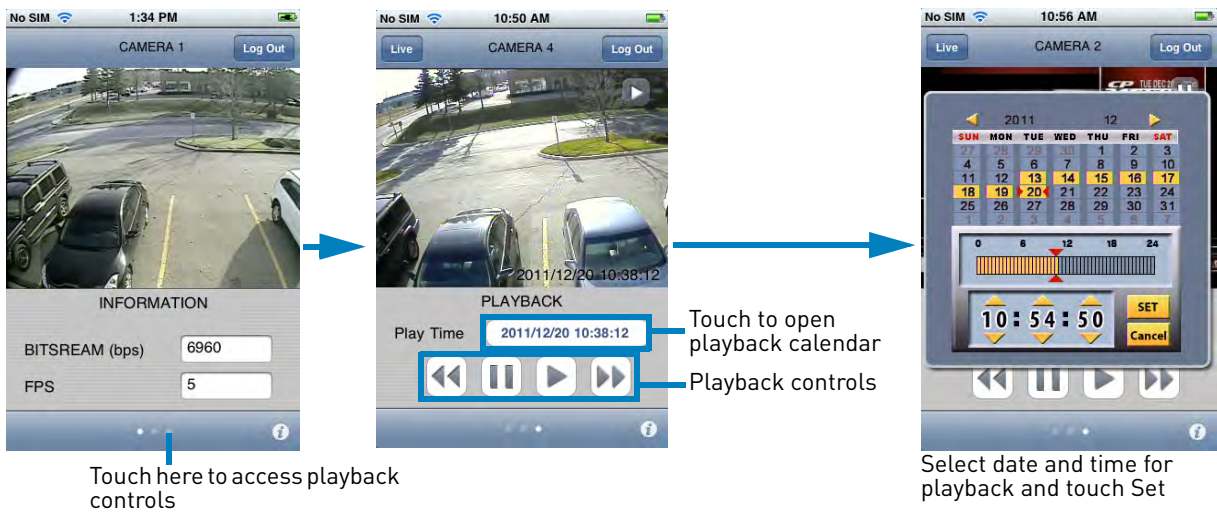

- 2 Touch the button next to Play Time to open the Playback Calendar.
- 3 Select the date and time for playback and touch **Set**.
- 4 Touch  to begin playback. It may take a few seconds for playback to begin. Use the playback controls to control playback. Touch **Live** to exit playback and return to live viewing.

Connecting To Your DVR on the iPad

- 1 Touch  to start the application. The DVR Setup screen appears.

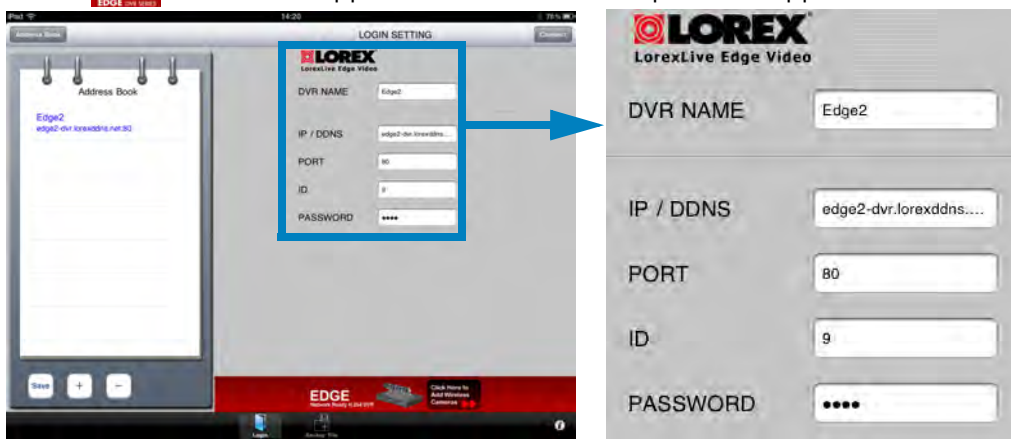

- 2 Under DVR NAME, enter a name for your DVR. This can be anything you want (Home, Office, etc.)
- 3 Under IP / DDNS, enter the **DVR's DDNS address** in full (e.g. *tomsmith.lorexddns.net*)¹.
- 4 Under PORT, enter the **HTTP Port** (default: **80**).

- 5 Under ID and Password, enter the **Remote Access user ID** (default: **9**) and **Password** (default: **3333**) for the DVR.
- 6 Touch the **Connect** button at the top-right corner of the screen.
 - If you are asked if you want to save changes, touch **YES** to save your DVR's information in the Address Book or **NO** to connect without saving your DVR's information.
- 7 The iPad connects to your DVR and displays streaming video. To disconnect from your DVR, touch **Exit**.

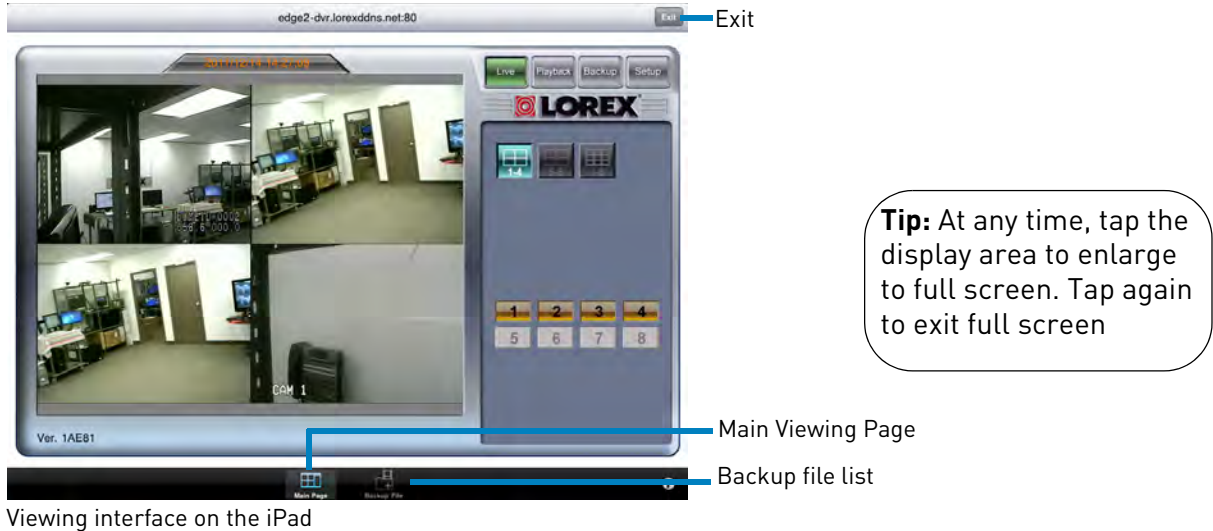

Viewing interface on the iPad

NOTE: The interface for navigating the app is the same as through the Client Software or an Internet browser, except some features are not supported, such as the Event List. See "PC and Mac Client Software for Remote Viewing" on page 62.

1. Some routers may prevent you from connecting to your DVR using a DDNS address on a local network. If you are unable to connect, try disabling WiFi on your mobile device and attempt to connect using the 3G or mobile network. If you need to use WiFi, use the DVR's internal IP address to connect.

Using the Address Book on the iPhone / iPad

The Address Book can save the device information for multiple Edge Series DVRs. This means you can easily switch between multiple DVRs located in your home, business, or elsewhere without having to re-enter the address or password.

On the iPad, the Address Book is shown on the left of the DVR Setup screen. On the iPhone, the Address Book is a separate window.

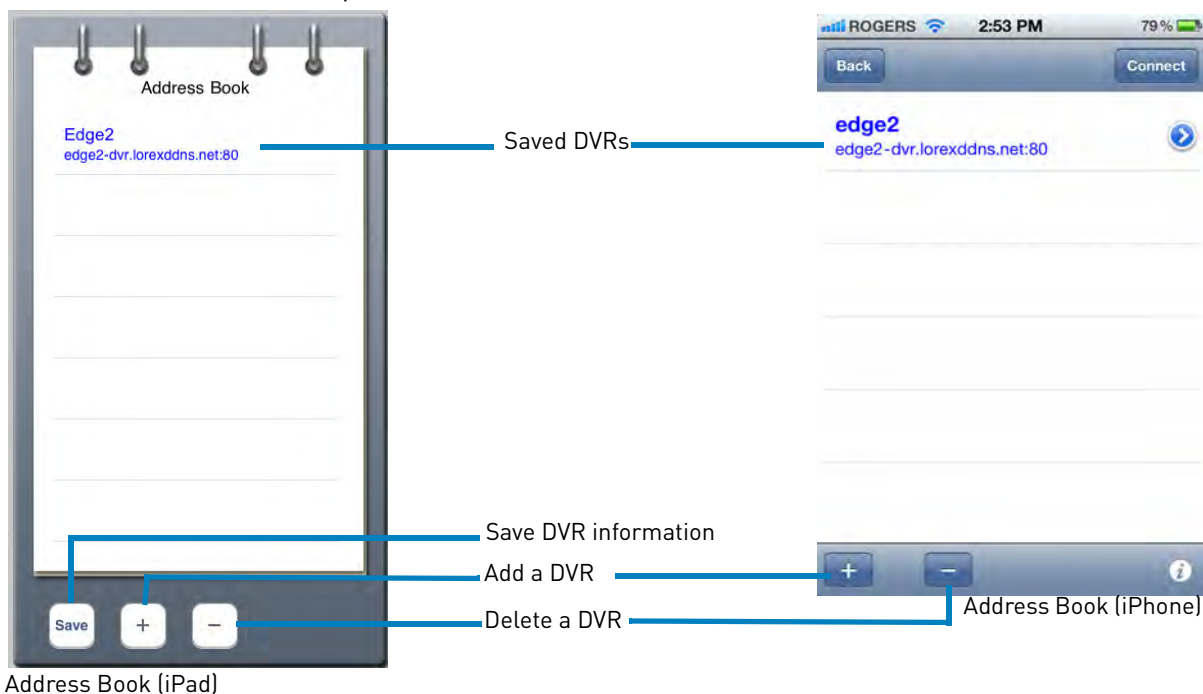

To connect to a DVR in your Address Book:

- Touch the name of the DVR you would like to connect to in the Address Book, and touch **Connect**.

To add a DVR to your address book:

- 1 Touch the **+** button. The DVR Setup screen opens (iPhone) or a new entry is added to the Address Book (iPad).
- 2 Enter the connection information for the DVR.
- 3 Touch **Connect** to connect to your DVR. Touch **Yes** to save your DVR's information in the Address Book. The iPhone/iPad connects to your DVR.

NOTE: On the iPad, you can also touch **Save** to save your DVR's information without connecting.

To delete a DVR from your Address Book:

- 1 Touch the name of the DVR you would like to delete in the Address Book.
- 2 Touch the **-** button and touch **Delete** (iPhone) or **Yes** (iPad) to confirm.

Accessing Backed up Video on the iPad

For instructions on how to back up video, See “Backup Mode” on page 67. Backed up video files can be accessed using the Backup File list.

To access backed up video files:

- 1 While you are logged into the DVR or from the DVR setup screen, touch the **Backup File** button (). The Backup File list opens.

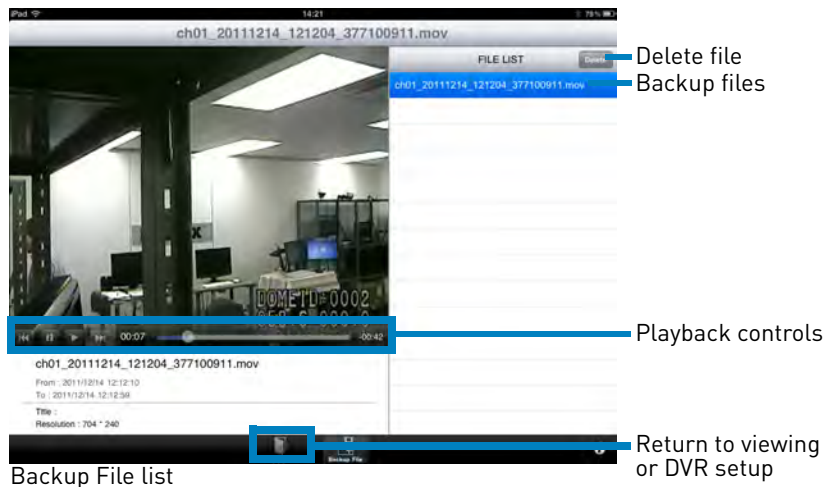

- 2 The first file in the Backup File list starts playing when the backup list opens. To play a different file, tap the filename in the File List.

To delete a backup file:

- 1 Tap the name of the file you would like to delete and touch the **Delete** button.
- 2 Touch **Yes** to confirm.

Android App

To connect to your DVR on an Android phone or tablet, you need to download and install the **Lorex Mobile Edge** app from the Google Play Store.

NOTE: You must have Android v. 2.1 or higher to use Lorex Mobile Edge. The instructions below may differ depending on the model of your Android device.

! You must port forward your router before you can connect to your system using a mobile device (e.g. Samsung Galaxy S, HTC Incredible S)

To download Lorex Mobile Edge:

- Download **Lorex Mobile Edge** from the Google Play store.

NOTE: For support on downloading or installing Android apps, consult your Android device's user's manual or the manufacturer's support site.

Connecting to your DVR on Android

- 1 Touch the Lorex Mobile Edge icon (). Lorex Mobile Edge opens to DVR Setup screen.
- 2 Under DVR NAME, enter a name for your DVR of your choice.
- 3 Under IP / DDNS, enter the **DVR's DDNS address** in full (e.g. *tomsmith.lorexddns.net*)¹. Touch **Next**.
- 4 Under PORT, enter the **HTTP Port** (default: **80**). Touch **Next**.
- 5 Under ID, enter the **Remote Access user ID** (default: **9**) for the DVR. Touch **Next**.
- 6 Under Password, enter the remote access **Password** (default: **3333**) for the DVR. Touch **Done**.
- 7 Touch the **Connect** button to connect to your DVR. Lorex Mobile Edge connects to your DVR and displays live streaming video.

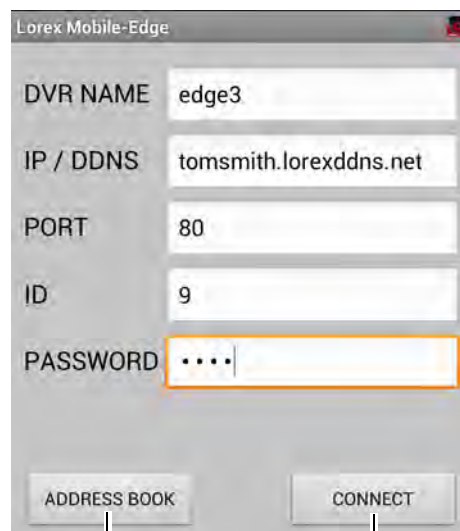

Tap to add DVR to Address Book

Tap to Connect

NOTE: To save your DVR's connection information in the app, touch **Address Book** then touch **Save**. To connect to a DVR in the Address Book, tap on the DVR and then tap **Connect**.

1. Some routers may prevent you from connecting to your DVR using a DDNS address on a local network. If you are unable to connect, try disabling WiFi on your mobile device and attempt to connect using the 3G or mobile network. If you need to use WiFi, use the DVR's internal IP address to connect.

Lorex Mobile Edge Viewing Interface

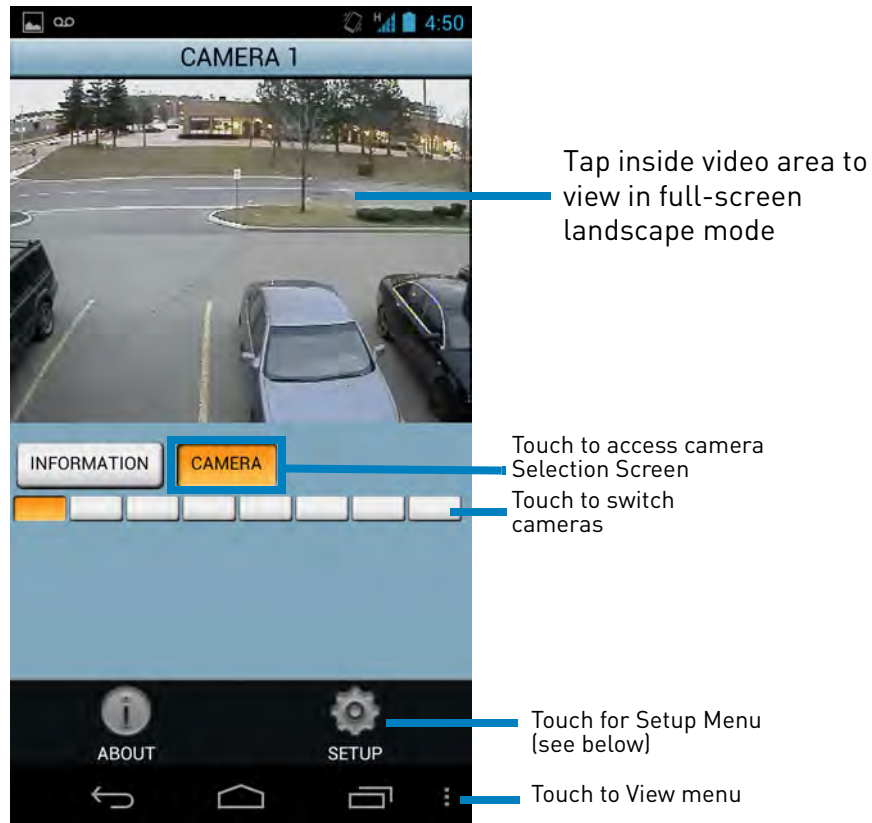

Lorex Mobile Edge shows a single camera view. When you connect to your DVR, Lorex Mobile Edge opens to the Information screen. The Information screen shows you the bitstream and frames per second (FPS) for your connection.

To switch cameras:

- 1 Touch the **Camera** button. The Camera Selection screen opens.
- 2 Touch the number of the camera you would like to switch to.

Setup Menu

Press the Menu button (☰) and then touch **Setup** (⚙️) to open the Setup Menu. The Setup menu contains the following options:

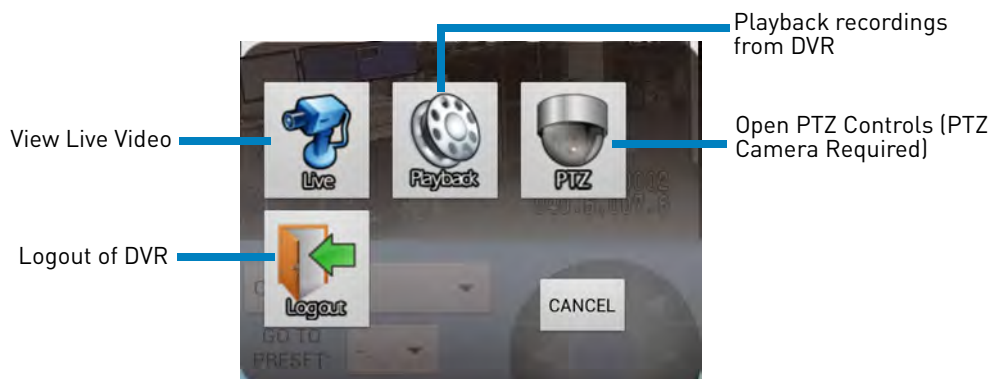

Playback Mode

Use Playback mode to view recorded footage from your DVR on your Android device.

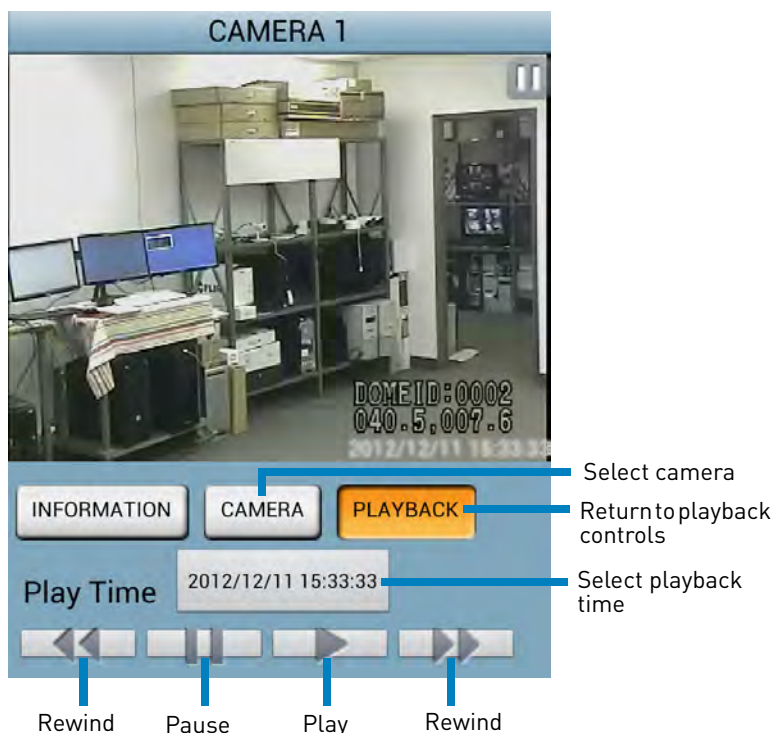

To use Playback mode:

- 1 Tap **Menu** (☰) → **Setup** (⚙️) → **Playback** to open Playback mode.
- 2 To select a camera for playback, touch **Camera**, touch the camera you would like to playback from, and then touch **Playback**.
- 3 Tap **Play Time**. Use the on-screen calendar to select the playback time then touch **Set**.



Playback Calendar

- 4 Press ▶ to start playback.

PTZ Controls

You can control your PTZ cameras (not included) and configure PTZ presets from your Android device.

NOTE: Before you can use PTZ controls, you must connect a PTZ camera to your DVR. See "Appendix C: Connecting PTZ Cameras" on page 108.

To control your PTZ cameras (not included) from your Android device:

- From Live View, press **Menu** () → **Setup** () → **PTZ**.
- Use the on-screen PTZ controls.

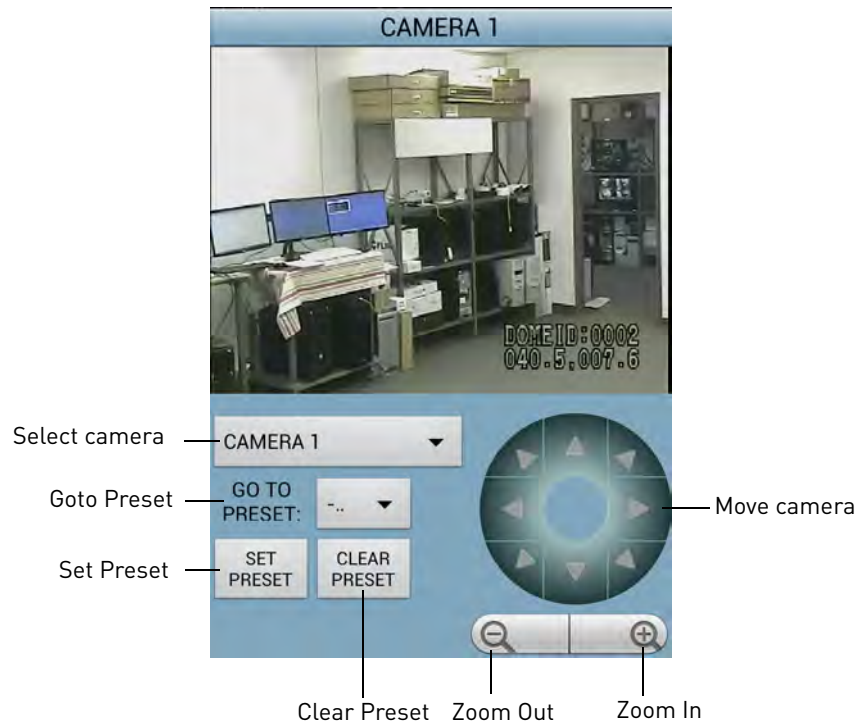

To set a PTZ Preset:

- 1 Move your camera into position.
- 2 Tap **Set Preset**.
- 3 Select a number to assign to this preset and tap **OK**.

To go to a PTZ preset:

- 1 Tap **Go to Preset**.
- 2 Select the Preset number. The camera moves into that preset position.

To clear a PTZ preset:

- 1 Tap **Clear Preset**.
- 2 Select the preset you would like to clear and tap **OK**.

Address Book

The Address Book can save the device information for multiple Edge Series DVRs. This means you can easily switch between multiple DVRs located in your home, business, or elsewhere without having to re-enter the address or password.

To connect to a DVR in your Address book:

- 1 Tap the name of the DVR.
- 2 Tap **Connect**.

To add a DVR to your Address Book:

- 1 Tap **Add**.
- 2 Input the device information for your DVR.
- 3 Tap **Save**.
- 4 To test the connection information, tap the name of your DVR and tap **Connect**.

To Delete a DVR from your Address Book:

- 1 Tap the name of the DVR.
- 2 Tap **Del**.
- 3 Tap **Delete** to confirm.

To edit the connection information for your DVR:

- 1 Tap the name of the DVR.
- 2 Tap **Edit**.
- 3 Edit the connection information as needed and then tap **Save**.
- 4 To test the connection information, tap the name of your DVR and tap **Connect**.



Address Book

Blackberry App

To connect to your DVR using a Blackberry smartphone, you must download and install the **Mobile View Application** from www.lorextechnology.com.

Requirements:

- Blackberry 8900, 9000, 9700, or 9800
- Blackberry Desktop Software

NOTE: Lorex does not support Blackberry Desktop Software. Blackberry may change their software interface without prior notice.

- Obtain your Blackberry's **APN** (Access Point Name) from your service provider, and enable APN on your Blackberry.

! You must port forward your router before you can connect to your system using a mobile device (i.e Blackberry 9000)

Installing Mobile View on the Blackberry:

- 1 On your computer, go to www.lorextechnology.com and search for the model number of your DVR [e.g. LH338].
- 2 Download the **Mobile View Application** from your DVR's product page. Extract the contents of the .zip file into a folder.
- 3 Connect the Blackberry to your computer using a USB cable.
- 4 Open Blackberry Desktop Software.
- 5 Click **Applications**. Wait for the applications list to populate.

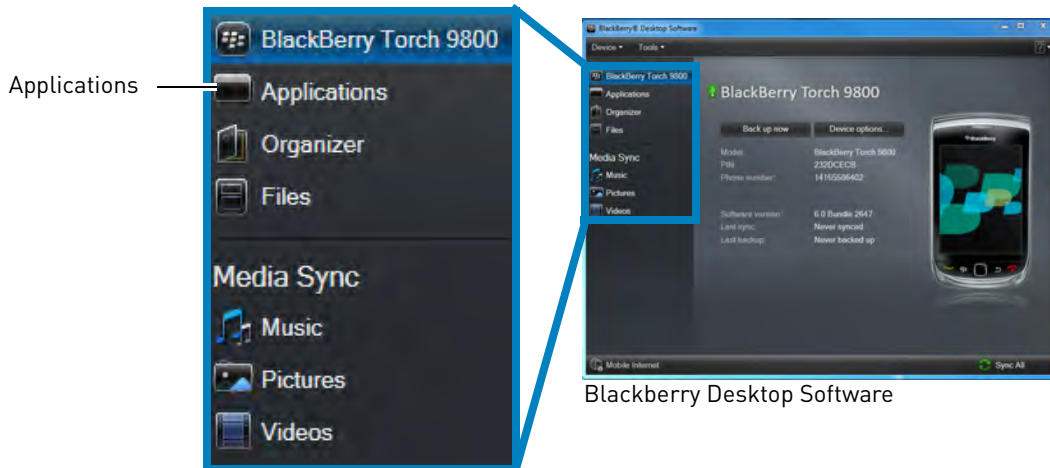

6 Click **Import Files**.

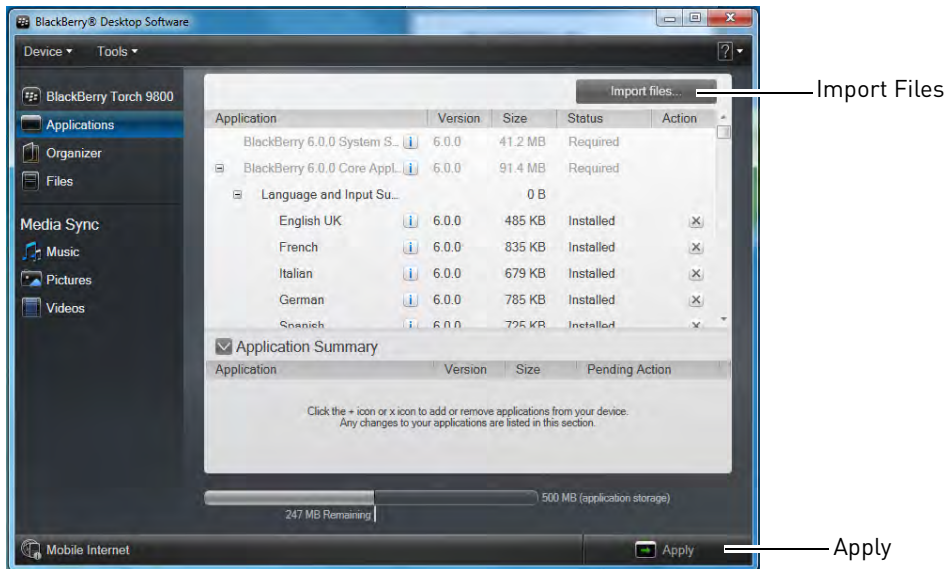

7 Locate the folder where you extracted the Mobile Viewer install files. Select the Mobile View install file (ends in an **.alx** extension), and then click **Open** to install the file.

8 Click **Apply** to complete the installation.

- Wait for the installation to complete.

NOTE: For support on installing Blackberry applications, consult your Blackberry smartphone's user's manual or visit www.blackberry.com.

Connecting to your DVR on your Blackberry

You can view your DVR remotely using your provider's 3G Network. Data charges may apply. See your cellphone carrier's network data plan for details.

NOTE: The instructions below may vary based on the model of your Blackberry smartphone.

1 Press the Menu button ().

2 Open the **Downloads** folder or locate **MobileView** in your application list.

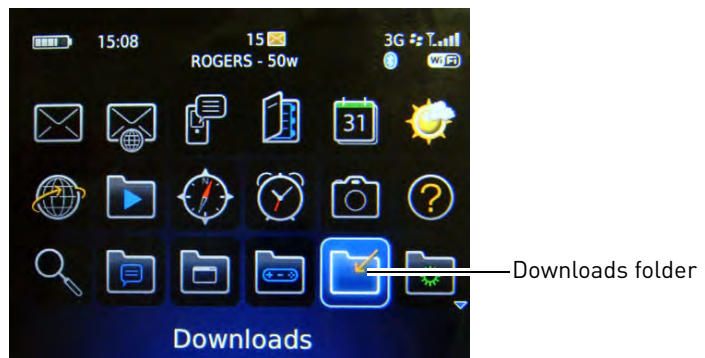

Opening the Downloads folder

- 3 Open the **MobileView** application.

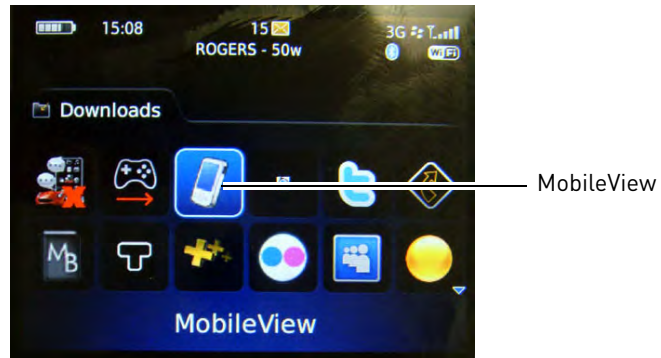

Opening Mobile View

- 4 Under IP/DDNS, enter the **DVR's DDNS address** in full (e.g. *tomsmith.lorexddns.net*)¹.
- 5 Under PORT, enter the DVR's HTTP port.
- 6 Under ID, enter the **remote access user ID** for the DVR.
- 7 Under PASSWORD, enter the **remote access password** for the DVR.

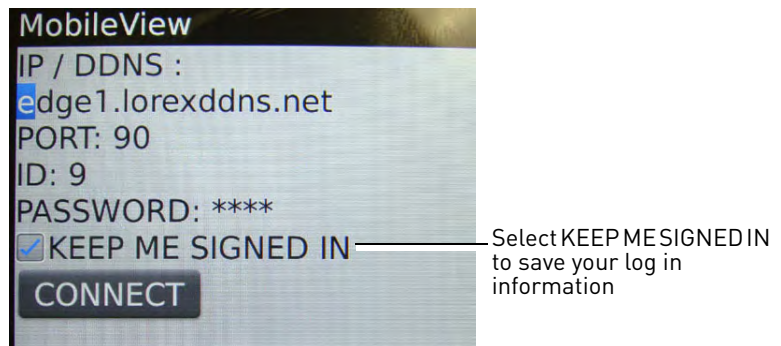

Connecting to your DVR

- If you would like Mobile View to save your user ID and password, check **Keep Me Signed In**.

- 8 Click the **CONNECT** button to begin live viewing.

NOTE: If you are unable to connect, check to make sure you have enabled APN on your Blackberry. For details, see "Enabling APN (Access Point Name) on Your Blackberry" on page 100.

Viewing Your DVR on your Blackberry

Once you have entered your DVR's system information, you can begin live viewing. You can view a single channel of video stream of your DVR. Split screen view is not available.

NOTE: If you exit Mobile View, you must wait 30 seconds before starting Mobile View again.

1. Some routers may prevent you from connecting to your DVR using a DDNS address on a local network. If you are unable to connect, try disabling WiFi on your mobile device and attempt to connect using the 3G or mobile network. If you need to use WiFi, use the DVR's internal IP address to connect.

To change the channel view:

- Press the number keys to jump to the desired channel (for example, press 3 to switch to channel 3).



Channel 1

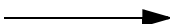

Channel 3

Connecting to your DVR

Viewing Tips:

- If you have wireless internet access at home, you may switch your Blackberry into WiFi mode. This allows you to monitor your system without incurring data charges on your 3G data plan.
- If your connection disconnects, wait 30 seconds before restarting Mobile View.

Enabling APN (Access Point Name) on Your Blackberry

In order for Mobile View to run, you must enable APN (Access Point Name) on your Blackberry. Contact your service provider for your Blackberry's APN name.

NOTE: The instructions below may differ based on the model of your Blackberry smartphone. For support related to enabling APN, please contact your smartphone service provider.

To enable APN:

- 1 Press the Menu button ().
- 2 Open the **Options** menu.



Options folder

Opening the Options folder

- 3 Select **Advanced Options** → **TCP/IP**

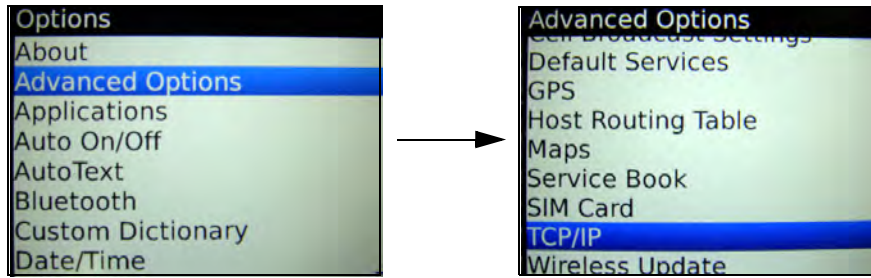

Opening APN settings menu

- 4 Select the checkbox beside **APN Settings** to enable APN.

Example

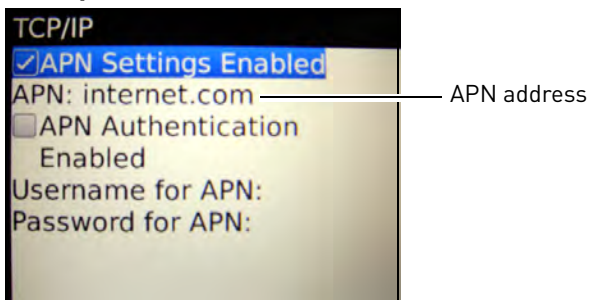

Enabling APN settings

- 5 Beside APN, enter your APN. **You must obtain the APN from your local service provider.**
- 6 Exit to save your settings.

Appendix A: System Specifications

EDGE2 Series

| SYSTEM | | PLAYBACK | |
|-------------------------------|--|------------------------------|--|
| Operating System: | Linux (embedded) | Playback Display: | 1,4,9 (8ch), 1,4,9,16 (16ch) |
| Pentaplex: | Simultaneous View, Record, Playback, Backup & Remote Configuration | Instant Playback: | for quick review of log events |
| Number of Channels: | 8/16 Channel | Playback Speed: | Variable (1, 5, 15, 60) |
| Inputs/Outputs | | Playback Player: | Apple QuickTime multi-hour Player |
| Video In: | 8/16 x 1 Vpp, CVBS, 75ohms, BNC | Backup Player: | Apple QuickTime multi-hour Player |
| VGA Out: | VGA compatible | Search: | By time, event, scroll |
| HDMI Out: | HDMI compatible | STORAGE & ARCHIVE | |
| Audio In: | 1 Line in(RCA) | Storage: | Up to 1 HDD (SATA) |
| Audio Out: | 1 line out(RCA) | Maximum Capacity: | Up to 2TB |
| USB Port: | 2 front & 1 back | Backup Media: | USB Flash Drive (max 16GB) |
| PTZ Control: | RS485 | Backup File Format: | MOV file (Codec included) |
| Display | | Bookmark Archiving: | Supported |
| Live Display: | 1 or 4 or 9 (8ch), 1 or 4 or 9 or 16 (16ch) | CONNECTIVITY | |
| Live Display Speed: | 240/480 (8/16ch NTSC) 200/400 (8/16ch PAL) | Easy Connect: | Loxex Auto Port Forward Wizard |
| OSD: | ON/OFF | Software: | Edge Client Software for PC & Mac |
| Activity Detection: | 1200 | Supported Operating Systems: | Windows™: 7, Vista, XP Mac |
| Sensitivity Levels: | 100 | Browsers: | Internet Explorer, Google Chrome (IE Tab) , Mozilla FireFox (IE Tab) |
| System Control: | USB Mouse, Front Panel Controls, Handheld Remote Control, Touch Screen (Windows 7 touch compatible) | Email Notification: | Text with weblink & snap shot attachment |
| Firmware Upgrade: | Via USB device | Mobile Connectivity: | iPad™, iPhone™ - 4.0 and above, Blackberry™ - (supported model numbers: 9000, 9700, 9800), Android (version 2.1) |
| User Authority: | ADMIN/USER1/USER2 | DDNS: | Free Lorex DDNS |
| Audio: | 1-way audio conference (via network) | Web Server Port: | Programmable by User |
| RECORDING | | Network Protocol: | LAN, DHCP, Dynamic IP, DDNS |
| Video Compression: | H.264 | Network Interface: | 10/100-Base-TX, RJ-45 |
| Audio Compression: | PCM | Network Speed Control: | 10 levels (28.8Kb ~ 1.5MB)/sec. |
| Recording Speed & Resolution: | 8/16 Channel 240 /200 @ 352x240 / 352x256 (NTSC / PAL) 120 /100 @ 704x240 / 704x256 (NTSC / PAL) 60 /50 @ 704x480 / 704x512 (NTSC / PAL) | GENERAL | |
| Recording Resolution Setting: | Programmable per camera | Power Consumption: | Approx. 30 watts |
| Recording Quality Control: | 5 levels | Supply Voltage: | 100VAC-240VAC, 12VDC, 2.5A, 50/60Hz |
| Image Size: | 24 Kbyte (704x480), 12 Kbyte (704x240) 6 Kbyte (352x240) | Unit Dimensions (W x D x H): | 11.6" x 6.2" x 1.1" 295mm x 167.4mm x 34.0mm |
| Recording Schedule: | By hour. by day, by recording mode, by Ch | Unit Weight: | 3.2 lbs |
| Recording Modes: | Continuous, motion activated | Operating Temperature: | 41° ~ 104° F / 5° ~ 40° C |
| Pre Recording: | Max. 10 seconds | Humidity: | 10 ~ 75% NC |
| Post Recording: | Max. 255 seconds | | |
| Reliability: | Watch-Dog, Auto-recovery after power failure | | |
| Covert Video: | Dynamic allocation of cameras | | |

As our products are subject to continuous improvement, Lorex Technology Inc. and its subsidiaries reserve the right to modify product design, specifications, and prices without notice and without incurring any obligation. *E&OE*

EDGE3 Series

| SYSTEM | | PLAYBACK | |
|-------------------------------|---|------------------------------|--|
| Operating System: | Linux (embedded) | Playback Display: | 1, 4, 9 (8ch), 1, 4, 9, 16 (16ch) |
| Pentaplex: | Simultaneous View, Record, Playback, Backup & Remote Configuration | Instant Playback: | For quick review of log events |
| Number of Channels: | 8/16 Channel | Playback Speed: | Variable (1, 5, 15, 60) |
| Inputs/Outputs | | Playback Player: | Apple QuickTime multi-hour Player |
| Video In: | 8/16 x 1Vp-p, CVBS, 75ohms, BNC | Backup Player: | Apple QuickTime multi-hour Player |
| VGA Out: | VGA compatible | Search: | By time, event, scroll, frame, date, file |
| HDMI Out: | HDMI compatible | STORAGE & ARCHIVE | |
| Audio In: | 1 Line in(RCA) | Storage: | Up to 1 HDD (SATA) |
| Audio Out: | 1 line out(RCA) | Maximum Capacity: | Up to 2TB |
| USB Port: | 2 front & 1 back | Backup Media: | USB Flash Drive (max 16GB) |
| PTZ Control: | RS485 | Backup File Format: | MOV file (Codec included) |
| Display | | Bookmark Archiving: | Supported |
| Live Display: | 1 or 4 or 9 (8ch), 1 or 4 or 9 or 16 (16ch) | CONNECTIVITY | |
| Live Display Speed: | 240/480 (8/16ch NTSC) 200/400 (8/16ch PAL) | Easy Connect: | Lorex Auto Port Forward Wizard |
| OSD: | ON/OFF | Software: | Edge Client Software for PC & Mac |
| Activity Detection: | 1320 | Supported Operating Systems: | Windows™; 8, 7, Vista, XP Mac |
| Sensitivity Levels: | 100 | Browsers: | Internet Explorer, Google Chrome (IE Tab) , Mozilla FireFox (IE Tab) |
| System Control: | USB Mouse, Front Panel Controls, Handheld Remote Control, Touch Screen (Windows 7 touch compatible) | Email Notification: | Text with weblink & snap shot attachment |
| Firmware Upgrade: | Via USB device | Mobile Connectivity: | iPad®, iPhone®- 4.0 and above, Blackberry™- (supported model numbers: 9800, 9700, 9000, 8900), Android (version 2.1) |
| User Authority: | ADMIN/USER1/USER2 | DDNS: | Free Lorex DDNS |
| Audio: | 1-way audio conference (via network) | Web Server Port: | Programmable by User |
| RECORDING | | Network Protocol: | LAN, DHCP, Dynamic IP, DDNS |
| Video Compression: | H.264 | Network Interface: | 10/100-Base-TX, RJ45 |
| Audio Compression: | PCM | Network Speed Control: | 10 levels (28.8Kb ~ 1.5MB)/sec. |
| Recording Speed & Resolution: | 8/16 Channel 240/200 @ 352x240 / 352x256 (NTSC/PAL) 120/160 @ 480x240 (NTSC) 100/133 @ 480x288 (PAL) 120/100 @ 720x240 / 720x256 (NTSC/PAL) 60/50 @ 720x480 / 720x512 (NTSC/PAL) 100/80 @ 960x240 / 960x288 (NTSC/PAL) 50/40 @ 960x480 / 960x576 (NTSC/PAL) | GENERAL | |
| Recording Resolution Setting: | Programmable per camera | Power Consumption: | Approx. 30 watts |
| Recording Quality Control: | 5 levels | Supply Voltage: | 100VAC-240VAC, 12VDC, 2.5A, 50/60Hz |
| Image Size: | 32 Kbyte (960X480), 16 Kbyte (960X240) 24 Kbyte (704x480), 12 Kbyte (704x240) 6 Kbyte (352x240) | Unit Dimensions (W x D x H): | 11.6" x 6.2" x 1.1" 295mm x 167.4mm x 34.0mm |
| Recording Schedule: | By hour, by day, by recording mode, by Ch | Unit Weight: | 3.2 lbs |
| Recording Modes: | Continuous, motion activated | Operating Temperature: | 41° ~ 104° F / 5° ~ 40° C |
| Pre Recording: | Max. 10 seconds | Humidity: | 10 ~ 75% NC |
| Post Recording: | Max. 255 seconds | | |
| Reliability: | Watch-Dog, Auto-recovery after power failure | | |
| Covert Video: | Dynamic allocation of cameras | | |

As our products are subject to continuous improvement, Lorex Technology Inc. and its subsidiaries reserve the right to modify product design, specifications, and prices without notice and without incurring any obligation. *E&OE*

Appendix B: Assigning a Fixed IP to your DVR

When connecting to your DVR through a local area network (LAN), you have the option of connecting to your system by entering the local IP of the DVR in a web browser. The local IP of your DVR is like your home's address. If someone wants to visit you, they need to know your home address. Similarly, the local IP of your DVR is your DVR's address.

The problem arises when the local IP address of the DVR changes. Imagine moving every three months—nobody would ever be able to find you. To solve this problem, we can assign a fixed IP address so that the local IP of your DVR will never change.

What's the difference between DHCP and Fixed IPs?

DHCP

DHCP (Dynamic Host Configuration Protocol) allows your router to automatically assign an IP address to devices that are connected to it. DHCP is a convenient method for connected devices on your router to have an IP address immediately. This allows devices connected to your router to work right away on the network.

In this example, your router has assigned an IP address to your laptop, your desktop, and your DVR.

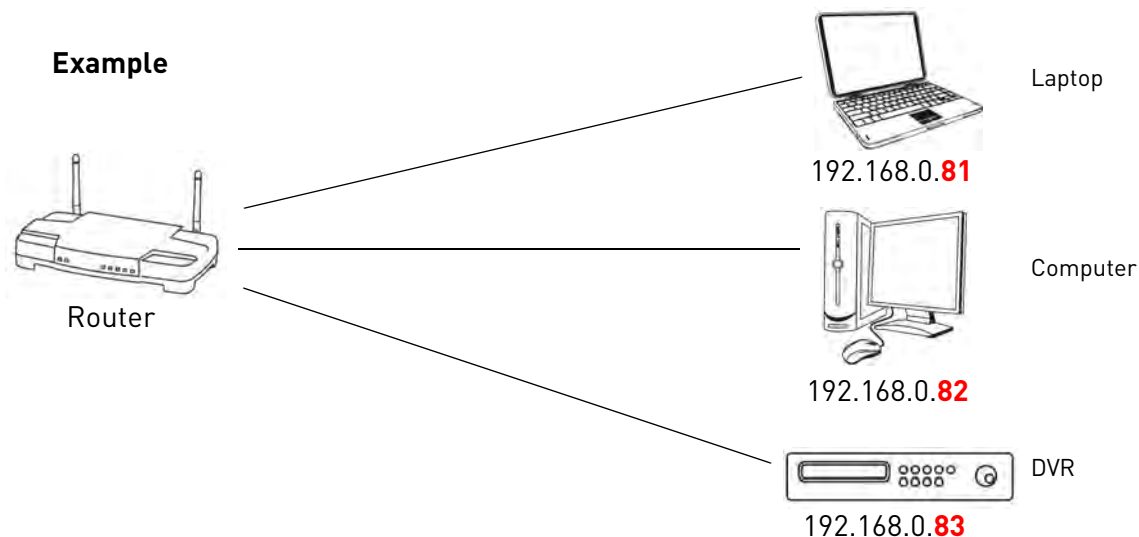

Each time the router restarts (due to power failure, etc.), there is no guarantee that the router will assign the same IP address to your laptop, desktop, or your DVR. The router may assign a new IP address to all of the devices connected to it. This can be a problem if you want to connect to your DVR locally, since the IP address of the DVR has changed.

This can also create problems for remote connections, because your port forwarding rules may be lost. Port forwarding requires you to specify the local IP address of your DVR. If that address changes, the router will no longer be forwarding the ports to the correct address, and you may have to re-configure port forwarding.

DHCP Scope

A DHCP scope is a range of IP addresses that your router can immediately assign to devices. A common DHCP scope is 100-255, although this varies between router models (check your router's owner's manual for more information). If the DHCP scope is 100-255 and the router's IP address is 192.168.1.1, this means that devices that connect using DHCP will be given an address in the range of 192.168.1.100 to 192.168.1.255. IP addresses between 192.168.1.2 and 192.168.1.99 are available for fixed assignment.

Fixed IPs

Setting a fixed IP on the router tells the router to reserve an IP address to a particular device. The fixed IP number is saved onto the router, and remains saved even if the router is powered off. Likewise, a fixed IP address must also be specified in your DVR so that even if your DVR turns off, the IP address of the DVR remains the same. The fixed IP address must be assigned in the DVR and must not be used by any other device on the network. The end result is that you can power on and off the router and DVR, and the router will always assign the same IP address to the DVR.

Setting up a Fixed IP Address

NOTE: These are guidelines on how to create a fixed IP. This example is using a Linksys E2500 router. Additional configuration may be required on your router. Refer to your router's owner's manual for details. The instructions below are for reference only.

Step 1 of 2: Determine the DHCP Scope of the Router:

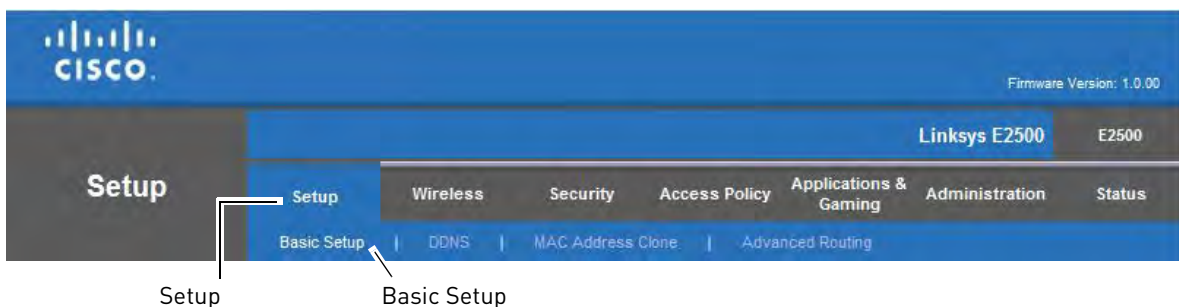

- 1 Open an Internet browser and enter **the router's IP address** in the address bar. Log in with the **router's user name and password**.
- 2 Select the **Setup** tab. Then select the **Basic Setup** tab.

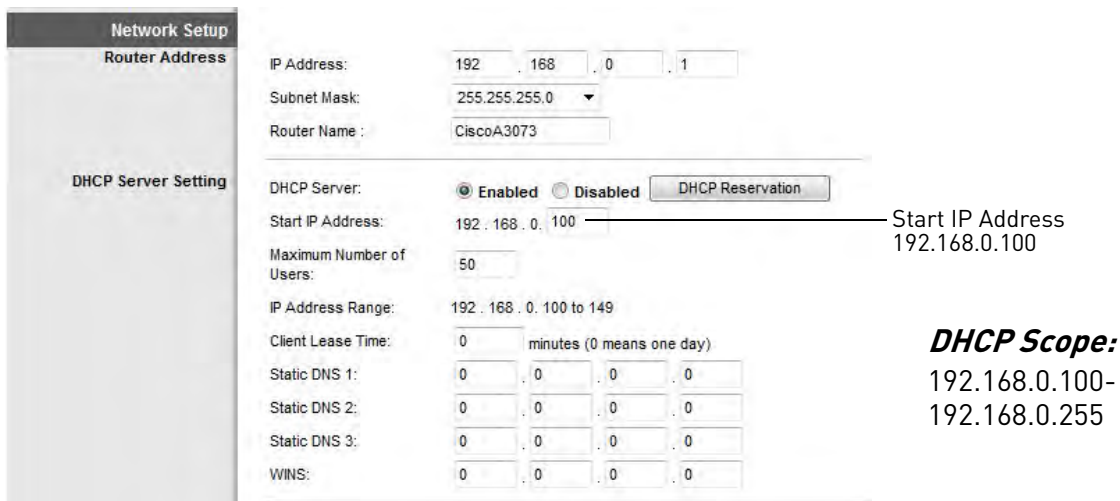

- Under DHCP Server Setting, locate the **Start IP Address**. This value is the first IP address that the router will assign to devices that connect with DHCP. This means that you can assign any IP address to your DVR that is lower than this value.



Step 2 of 3: Disable DHCP on the DVR and Assign a Local IP Address Outside the DHCP Scope

- Click  to open the Main Menu, and then click . The LAN Menu opens.
- Beside **IP**, enter the desired IP address. This IP address must be outside the DHCP range specified by your router. In the example, the DHCP range begins at 192.168.0.100, so we can choose 192.168.0.89.
- Beside **DHCP Enable**, select **X** to disable DHCP. Right-click to save your settings.

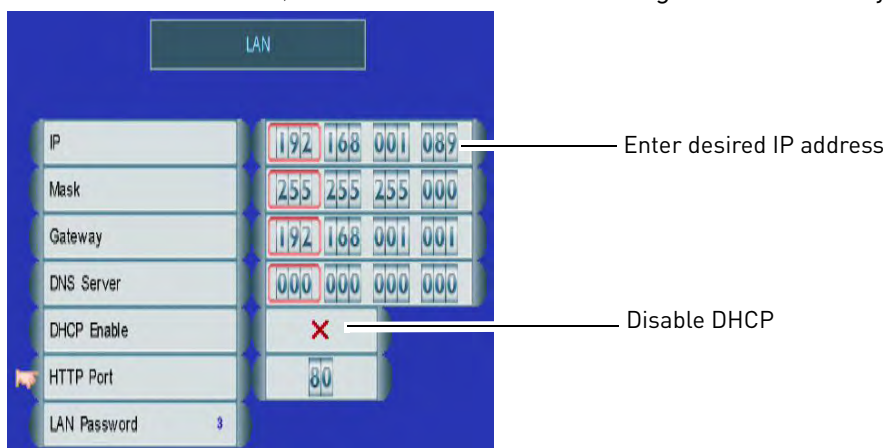

- Restart the DVR by disconnecting the power adapter from the rear panel and reconnecting it to the **DC 12V** port.

- 5 To confirm that the new port number is saved on your system, press the  button on the front panel or remote control to view the System Information

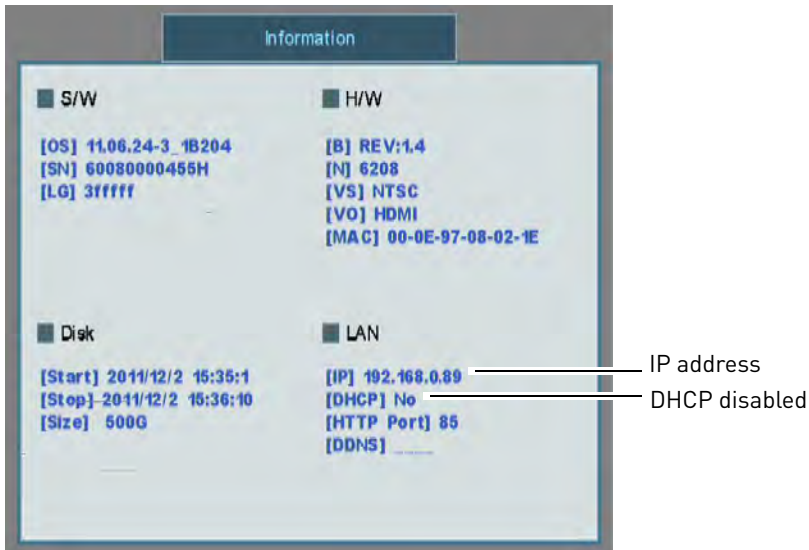

Confirm the new IP address

You have now assigned a fixed IP address to your DVR. The DVR will always be assigned the same IP address, even if the DVR or router is restarted.

If you have already completed router port forwarding, you will need to re-configure your router to forward the newly selected IP address. If your DVR List includes the local IP address of your DVR, you will have to update it to use the newly selected IP address.

Appendix C: Connecting PTZ Cameras

You can connect RS-485 PTZ cameras (not included) to the RS-485 port on the rear panel.

To connect a PTZ camera to the DVR:

- 1 Connect the Transmit+ (TX+) cable to the **+** side of the **RS-485** port on the rear panel.
- 2 Connect the Transmit- (TX-) cable to the **-** side of the **RS-485** port on the rear panel.
- 3 Connect the video cable to an available BNC port (8-channel) or an available connector on one of the BNC Octopus connectors (16-channel).

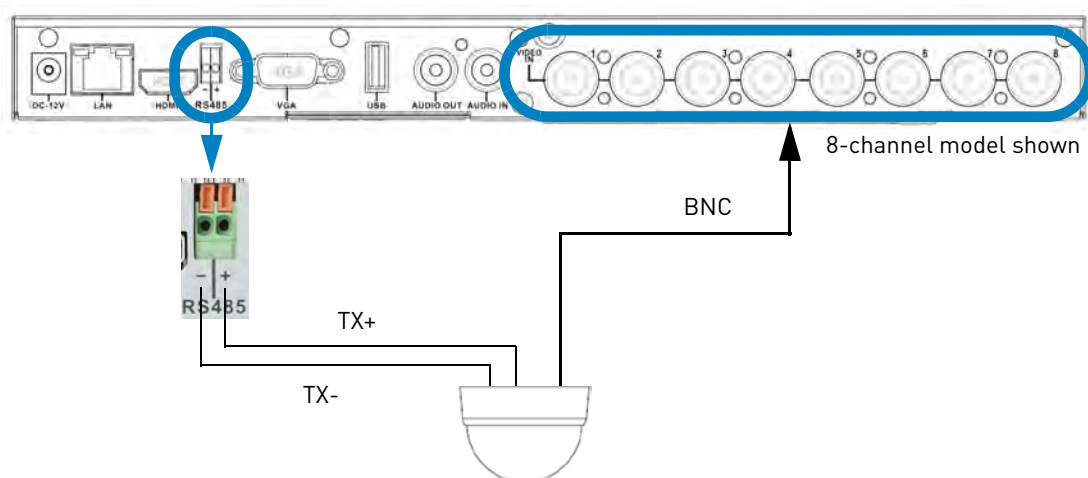

To enter PTZ camera settings in the DVR:

- 1 Obtain the PTZ protocol details for your camera. Check your camera's instruction manual for details.
- 2 Click **MENU** then .
- 3 Click **RS-485**. The RS-485 Menu opens.
- 4 Click **Baud Rate** and scroll up/down to select the baud rate for your camera.
- 5 Click **PTZ Camera Setup**. Select the channel your PTZ camera is connected to. The PTZ Camera Setup Menu opens.
- 6 Click **Camera ID** and scroll up/down to select the ID for your camera.
- 7 Click **Control Enable** and select **0** to enable PTZ controls for the selected channel.

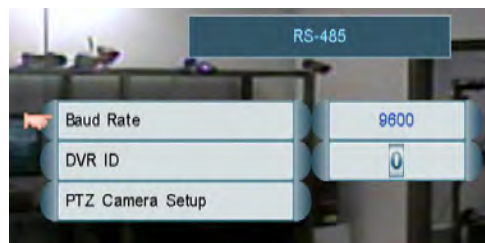

RS-485 Menu

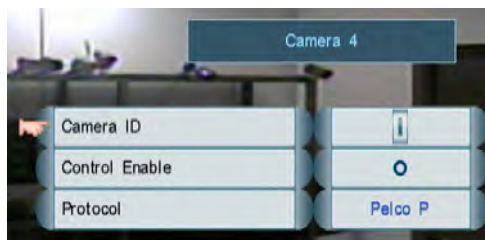

PTZ Camera Setup Menu

- 8 Click **Protocol** and scroll up/down to select the PTZ protocol for your camera.
- 9 Right-click until you have exited all menus to save your changes.



Controlling PTZ Cameras

To access PTZ controls locally on your DVR:

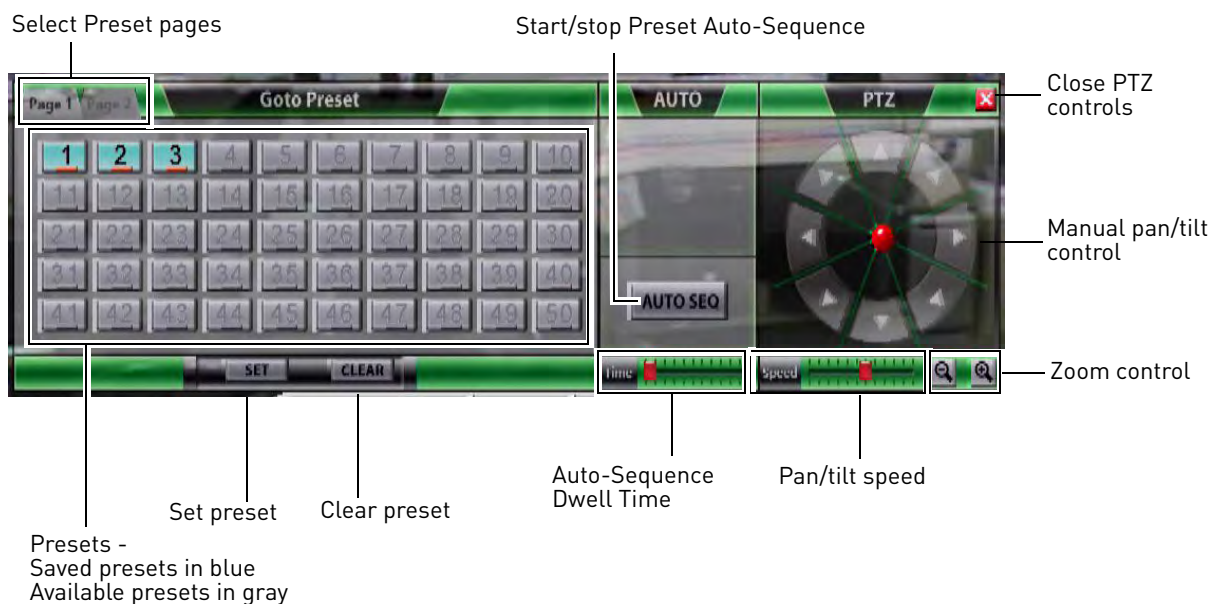
- 1 Select the channel that your PTZ camera is connected to. If your DVR is in Split-Screen view, click the channel for your PTZ camera to view it in Full-Screen / Single-Channel mode.
- 2 Click . PTZ controls appear.



To manually control the camera pan/tilt and zoom:

- Under PTZ, Click and drag the red joystick in the middle or click the arrows to adjust the camera pan/tilt. Click  to zoom in or  to zoom out.

To adjust pan/tilt speed:

- Click inside the pan/tilt **Speed** adjuster.

NOTE: This setting only applies to manual pan/tilt control. It does not affect Preset Auto-Sequence.

Using PTZ Presets

PTZ presets allow you to save PTZ camera positions for quick retrieval later. The DVR can support up to 100 preset points. You can also use Preset Auto-Sequence to have the camera automatically cycle through created presets.

NOTE: Click **Page 2** to view presets 51~100.

Creating PTZ Presets

- 1 Adjust the camera position and zoom as needed.
- 2 Click **SET**. The presets available turn blue.
- 3 Click the number of an available preset to save the camera position to that preset.

Loading PTZ Presets

- Click the number of the preset you would like the camera to go to.

Deleting PTZ Presets

- Click **CLEAR** then click the number of the preset you would like to delete.

Using Preset Auto-Sequence

When Preset Auto-Sequence is activated, the camera will cycle through all created presets in numerical order. For example, the camera will go from Preset 1, to Preset 2, and continue in order until it reaches the last saved preset, at which point it will return to Preset 1.

The camera will pause for a few seconds in between each preset, depending on the Time setting.

To start Preset Auto-Sequence:

- 1 Create some presets using the steps above.
- 2 Adjust the **Time** bar. The further to the right the cursor is, the longer presets will be shown before changing.
- 3 Click **Auto SEQ** to start Preset Auto-Sequence. The camera will begin moving between preset positions. Once Preset Auto-Sequence is started, you may click **X** to exit the PTZ controls, and the camera will continue to move automatically.

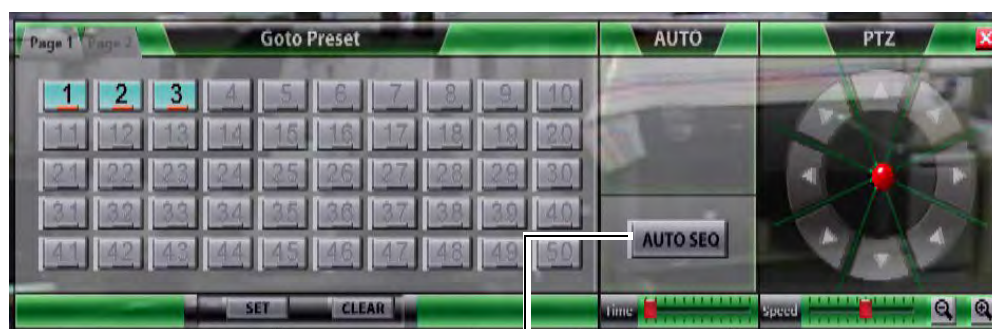

Start/stop Preset Auto SEQ

Adjust the time presets are shown before switching

NOTE: Preset Auto-Sequence will stop if you use any of the manual PTZ controls.

- 4 Click **Auto SEQ** again to stop Preset Auto-Sequence.

Appendix D: Recording and Playing Audio



The DVR is capable of recording one audio channel, which can be assigned to any available camera channel. Audio recording requires an audio-capable camera (not included) or self-powered microphone (not included).

The DVR can play audio from self-powered speakers (not included) or from an HDMI TV or monitor (not included) with internal speakers.

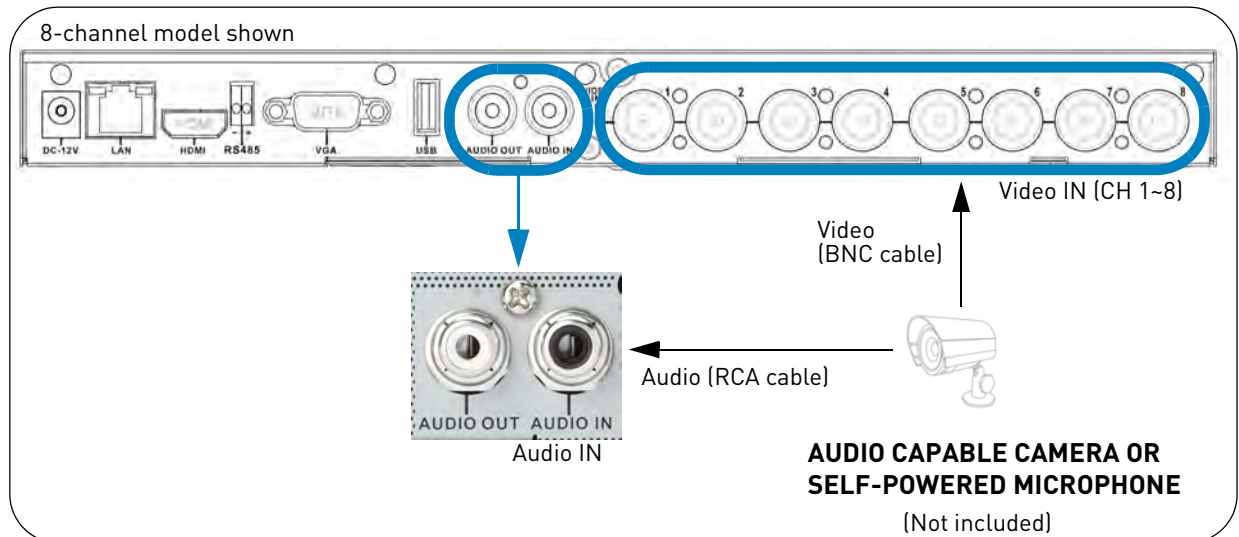
Connecting an Audio-Capable Camera or Self-Powered Microphone



NOTE: It is recommended to test the audio and video on your cameras prior to installation.

- 1 [Camera only] Connect the BNC video cable from your camera to one of the available **Video IN** ports on the rear panel of the DVR (8-channel) or an available connector on one of the Octopus BNC connectors (16-channel).
 - For RCA cameras, use an RCA-to-BNC adapter to connect the yellow RCA video connector to the Video IN ports or Octopus BNC connectors.
- 2 Connect the white RCA audio connector from the camera or microphone to the **Audio IN** port on the rear panel of the DVR.
- 3 Connect the camera or microphone to a power outlet and power it on.
- 4 On the DVR, click . Click  to access the Record Menu.
- 5 Click **Video Frame Rate**. The Video Frame Rate Menu opens.

6 Click **Audio**, and then scroll up / down to select the channel your camera is connected to.

- If you are using a self-powered microphone (not included) select the channel you would like to record audio to.

7 Right-click to save your changes and return to the Record Menu. Continue right-clicking to exit all menus and return to live viewing.

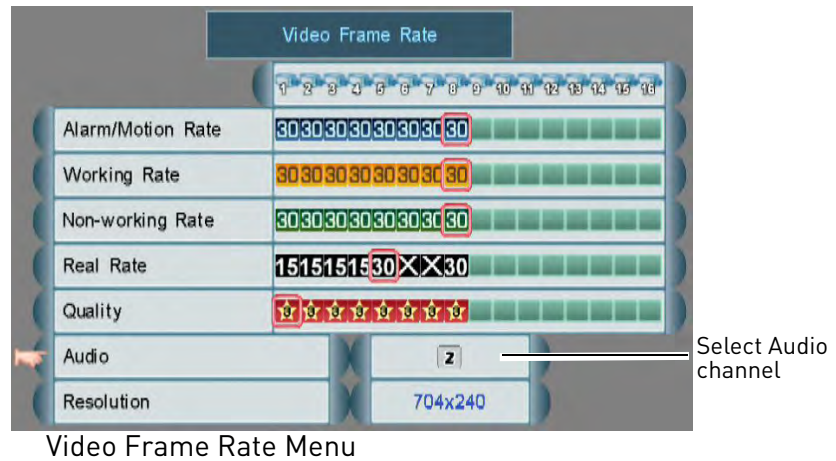

NOTE: The DVR will record audio from your camera according to the recording settings; however, it will only play audio when the audio-enabled channel is selected in Full-Screen / Single-Channel mode. It will not play audio in Split-Screen mode.

Playing Audio from your DVR

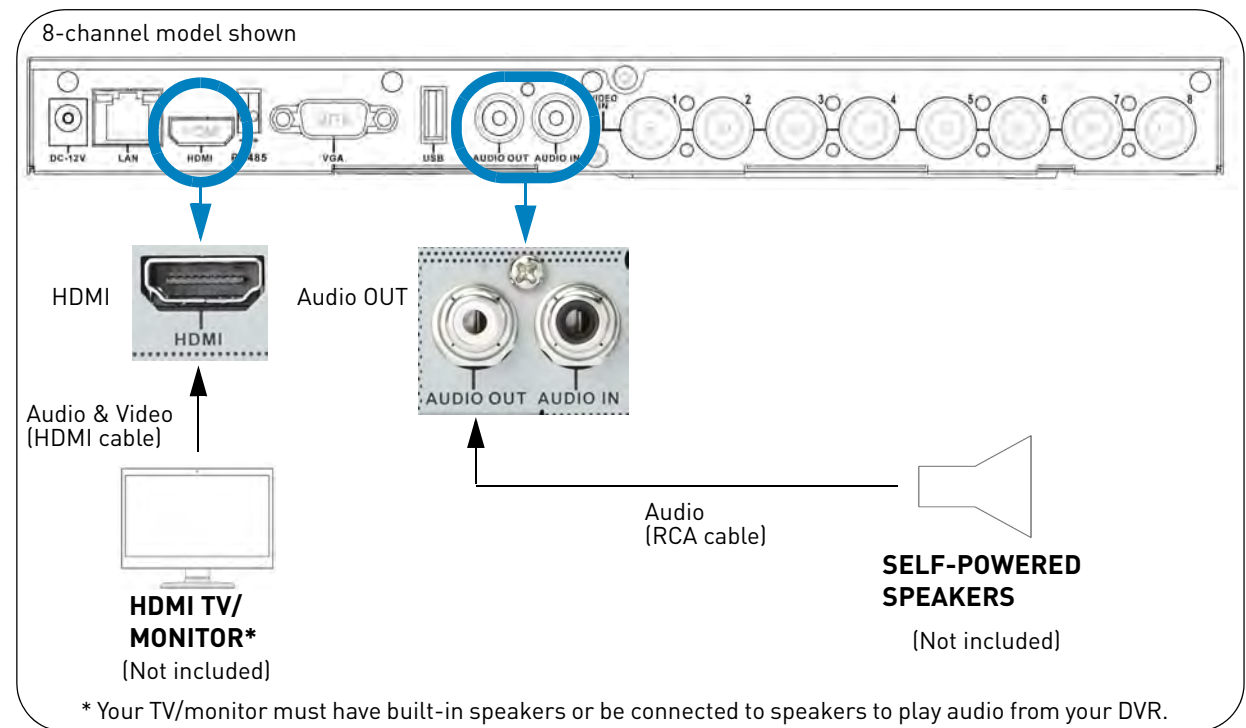

- Connect an HDMI cable (not included) from the **HDMI** port on the rear panel of the DVR to an HDMI port on a TV or monitor with internal speakers. Power on the TV or monitor.
- **OR** Connect a RCA audio cable (not included) from the **Audio OUT** port on the rear panel of the DVR to a set of self-powered speakers (not included).

NOTE: You can only play audio from the DVR if an audio-capable camera (not included) or self-powered microphone (not included) is connected.

Appendix E: Mounting the DVR to a VESA Mount

The DVR is designed to mount to the back of most LCD monitors with a VESA mount. You may also mount it to a wall or leave the system in a standard horizontal or vertical position.

ATTENTION: You can only mount the DVR to an LCD monitor or TV that has a VESA mount and an independent stand, with clear access to the VESA mount holes. The DVR supports the following VESA mount sizes: 75mm x 75mm, 100mm x 100mm, and 200mm x 200mm.

- 1 Screw the provided mounting screws into the top two holes in the rear panel of your LCD monitor or TV. Make sure the screws are only $\frac{3}{4}$ of the way in; this will allow sufficient clearance to hang the system.

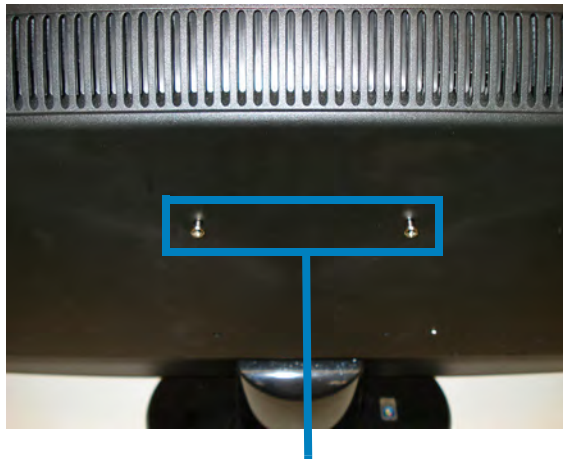

Mounting screws attached to monitor

- 2 With the front panel of the DVR facing up, carefully align 2 of the VESA mounting holes on the DVR over the mounting screws and slide down into place.

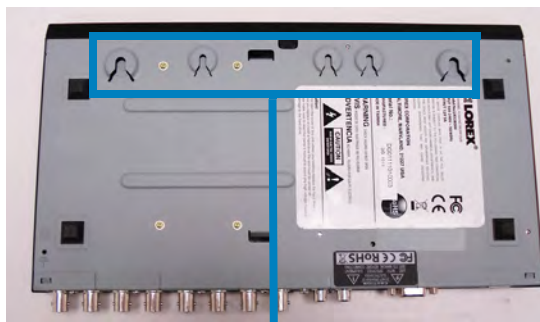

VESA mounting holes

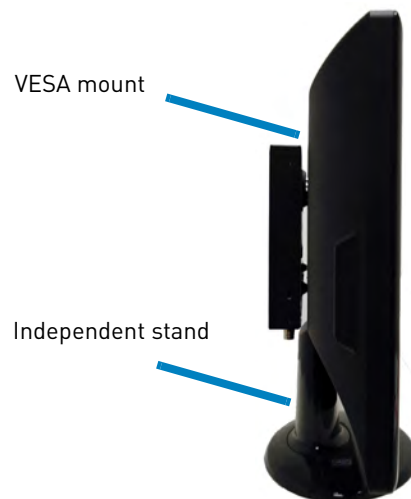

VESA mount

Independent stand

Appendix F: Replacing the Hard Drive

The system comes with a pre-installed 3.5" SATA hard drive. You can expand the system with a replacement single hard drive up to 2 terabyte (TB).

NOTE: It is recommended to use surveillance or security-certified hard drives, which are designed to be reliable over long periods of time while recording 24/7. Security-certified hard drives are available at www.lorexttechnology.com

Removing the Hard Drive



Make sure that the power cable has been disconnected before changing the hard drive.

To remove the hard drive:

- 1 Remove the single screw on the back panel of the DVR.



8-channel model shown

- 2 Remove the screws (x2) on each side panel of the DVR.



Side panel screws

- 3 Lift the top panel of the DVR up from the back, and slide it towards the back of the DVR to remove it.

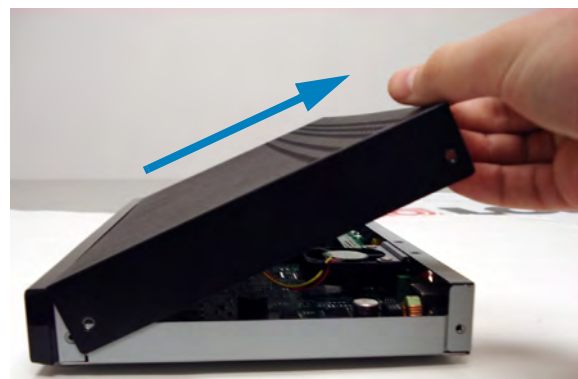

- 4 Hold the hard drive in place with your hand and carefully turn the DVR over. Remove the hard drive screws (4x) on the bottom panel of the DVR.



It is **EXTREMELY IMPORTANT** that you hold the hard drive in place while turning the DVR over and removing the bottom panel screws. Not holding the hard drive can break the DVR.



Hard drive screws

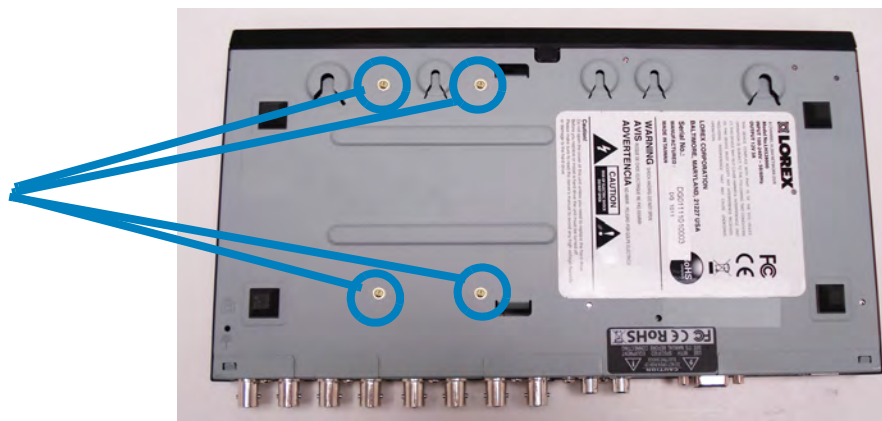

- 5 Carefully slide the hard drive back until it is clear of the SATA connector and lift it out of the DVR.

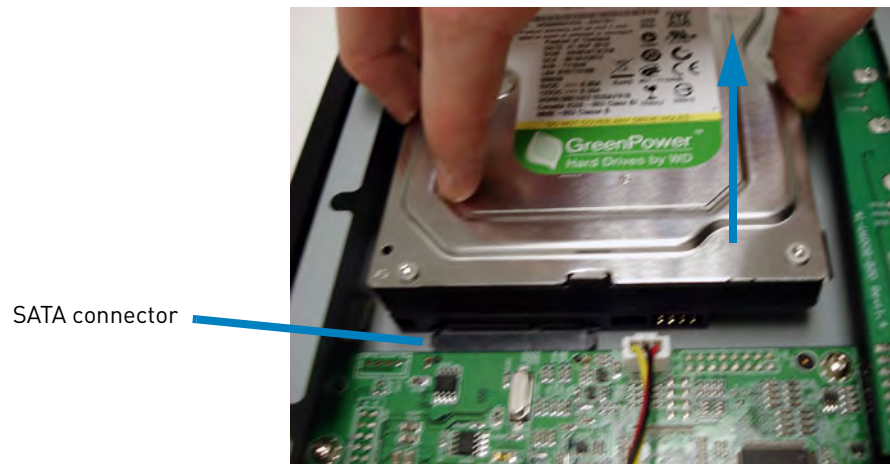

Replacing the Hard Drive

To replace the hard drive:

- 1 Place the hard drive into the DVR. Make sure to align the SATA ports on the hard drive with the DVR SATA connector.

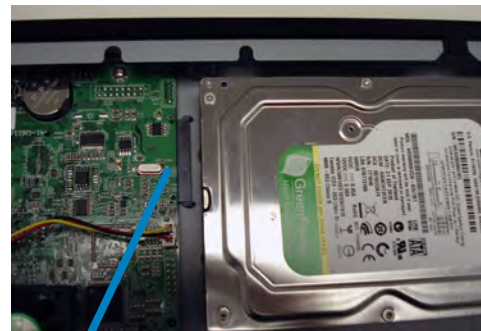

- 2 Slide the hard drive onto the DVR SATA connector.
- 3 Hold the hard drive in place with your hand and carefully turn the DVR over. Replace the hard drive screws (4x) on the bottom panel of the DVR.



It is **EXTREMELY IMPORTANT** that you hold the hard drive in place while turning the DVR over and replacing the bottom panel screws. Not holding the hard drive can break the DVR.



- 4 Carefully turn the DVR back over.
- 5 Hold the top panel of the DVR at an angle, and insert the panel edges under the lip on the front panel. Lower the top panel onto the DVR.
- 6 Replace the screws (2x) on each of the side panels of the DVR.
- 7 Replace the single screw on the back panel of the DVR. **You must format the hard drive for the DVR to detect it.** For details, see "Formatting the Hard Drive" on page 117.



Top panel edges



Formatting the Hard Drive

If you replace the pre-installed hard drive, it *must* be formatted in order to function properly with the system.

ATTENTION: Formatting the HDD erases **all data** on the hard disk.
This step cannot be undone.

To format the hard disk:

- 1 From the Main Menu, click . The Record Menu opens.
- 2 Select **Format HDD**.
- 3 Click **Yes** to format the hard drive or click **No** to cancel.
Please allow a few seconds for formatting to occur.

NOTE: You will notice that the size of the HDD and the free space are not the same. The system uses a portion of the disk space for the operating system and initialization. This is common in all security DVRs as well as computer hard drives.

Appendix G: Upgrading Firmware

Firmware upgrades can provide improved functionality to your DVR. When firmware upgrades become available, you can download them for free from www.lorexttechnology.com

Prior to upgrading your system's firmware, you must first format your USB flash drive (not included) so it will function properly with the DVR.

ATTENTION: Formatting erases *all data* on the USB flash drive. This step *cannot* be undone.



To upgrade firmware:

- 1 Connect a USB flash drive (not included) to one of the **USB** ports on the DVR and format it (see "Formatting the USB Drive" on page 43). Once formatting is complete, remove the USB flash drive and connect it to a USB port on your computer.

NOTE: The system creates two folders on your USB drive: *Picture* and *Movie*.

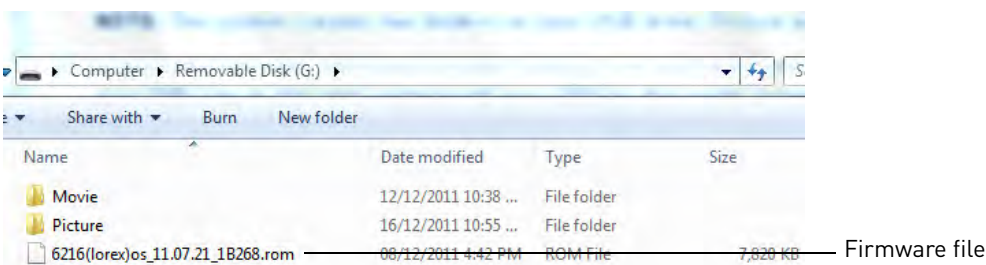
- 2 In your web browser, visit www.lorexttechnology.com and search for your DVR series. Download the free firmware upgrade from the Downloads tab if one is available.
- 3 Extract the firmware file and copy it to the main directory of the USB flash drive—*do not* place the file in either the *Picture* or *Movie* folder. Once the file transfer is complete, remove the USB flash drive from your computer.



- 4 Connect the USB flash drive to the DVR.
- 5 Click  to open the Main Menu. Click  to open the Backup Menu, then click **Firmware Update**.

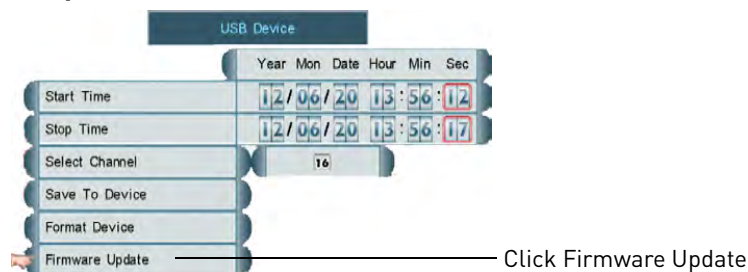

- 6 The system checks the USB flash drive for a compatible firmware file and asks you to confirm the upgrade. Click **Yes** to begin the firmware upgrade. **DO NOT unplug the DVR or disconnect the USB flash drive while the upgrade is installing.** The system will prompt you when the upgrade is complete.
- 7 When the upgrade is completed, remove the USB flash drive from your DVR and disconnect the power adapter to power off your DVR. Reconnect the power adapter. The DVR is now upgraded with the new firmware.

If you do not see Buttons in DVR Netviewer After Upgrading the Firmware...

You need to reset the cache in your web browser. See below for instructions on how to reset the cache in Internet Explorer 8. For other browsers, please see the support resources provided by the publisher.

To reset the cache in Internet Explorer 8:

- 1 Open Internet Explorer.
- 2 Click on **Tools** → **Internet Options**.

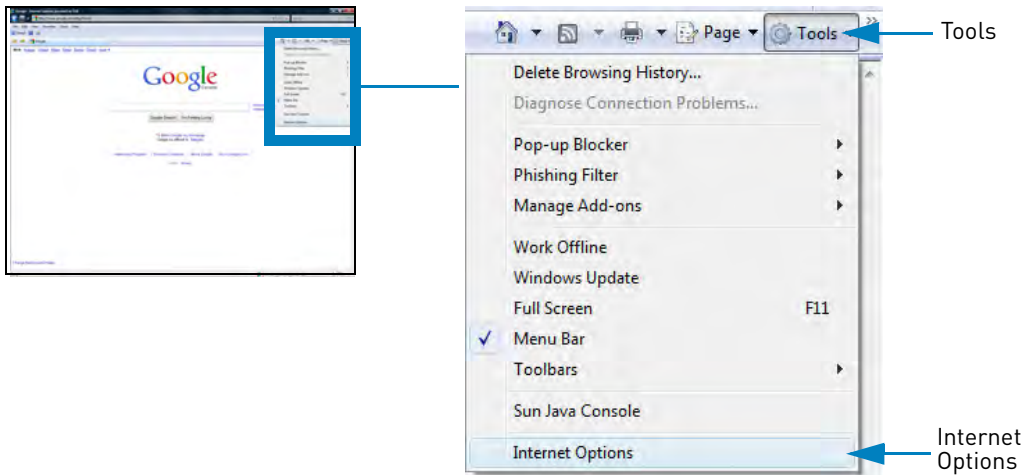

- 3 Under **Browsing History**, click the **Delete** button.

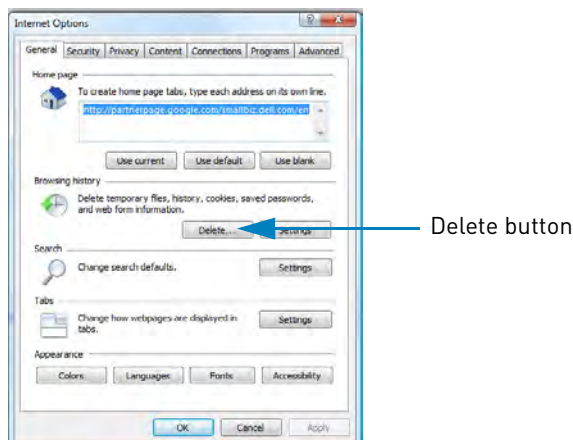

What does the cache folder do?

The cache folder contains files from web pages—images, downloaded content—from browsing the web. This allows a web browser to quickly recall certain elements of websites from the cache folder, creating faster load times.

When the cache folder becomes too full, web pages may not load correctly on Internet Explorer.

- 4 Click the **Delete all** button.
NOTE: Clicking the Delete all button clears all internet history, temp files, cookies, and saved form data.
- 5 Click **Yes** on the prompt.
- 6 Click **Close** and then click **OK** to exit and save your changes.
- 7 Restart Internet Explorer.
- 8 After you have cleared your internet cache, reconnect to your DVR. You may have to re-install ActiveX plug-ins upon initial connection.

If you still have problems connecting to your DVR after clearing your Internet Explorer cache, try setting your Internet Explorer security settings to "Medium-high." Or alternatively, use Lorex Client 12 (provided on the CD) to connect to your DVR. For installation instructions, see "Step 3 of 4: Install the Client Software on your PC or Mac" on page 53



To set your security settings in Internet Explorer 8:

- 1 Open Internet Explorer.
- 2 Click **Tools**→**Internet Options**.
- 3 Click the **Security** tab.
- 4 Under Security levels for this zone, drag the slider and set the security level to **Medium-high**.

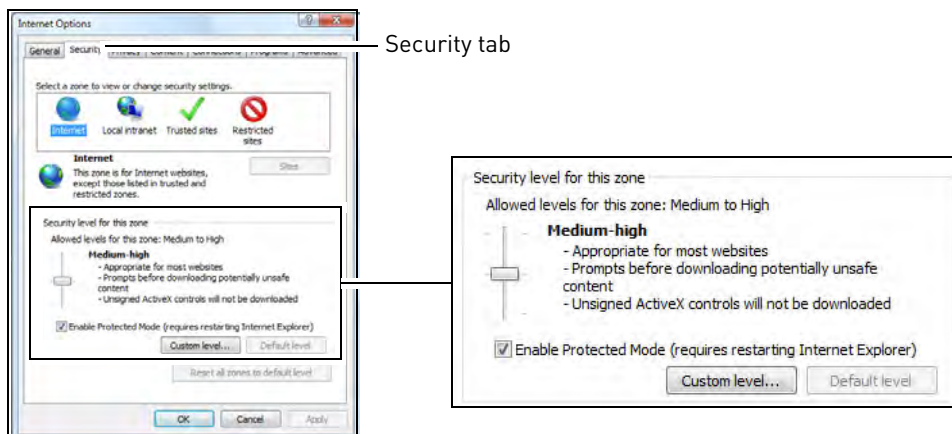

- 5 Click **OK** to save your settings. Restart Internet Explorer, and reconnect to your DVR.

Troubleshooting

When a malfunction occurs, it may not be serious and can be corrected easily. The following describes the most common problems and solutions. Please refer to the following before calling Lorex Technical Support:

| Error | Possible Causes | Solutions |
|---|--|---|
| <ul style="list-style-type: none"> System is not receiving power, or is not powering up | <ul style="list-style-type: none"> Cable from power adapter is loose or is unplugged | <ul style="list-style-type: none"> Confirm that all cables are connected correctly Confirm that the power adapter is securely connected to the back of the unit and is connected to a power outlet |
| | <ul style="list-style-type: none"> Cables are connected, but system is not receiving sufficient power | <ul style="list-style-type: none"> Confirm that the system is powered on (LED indicator on the front should be on or flashing) If the unit is connected through a power bar or surge protector, try bypassing the bar and connecting the power directly to the wall outlet Confirm that there is power at the outlet: <ul style="list-style-type: none"> Connecting the power cable to another outlet Test the outlet with another plugged device (such as a lamp or phone charger) |
| <ul style="list-style-type: none"> Remote control is not detected by the system | <ul style="list-style-type: none"> Battery in the remote control is drained | <ul style="list-style-type: none"> Install a fresh CR2025 battery in the remote control |
| | <ul style="list-style-type: none"> There are no batteries in the remote control | |
| | <ul style="list-style-type: none"> Remote control does not have line of sight to the DVR | <ul style="list-style-type: none"> Install the IR extender where it will have line of sight to the remote control |
| <ul style="list-style-type: none"> Hard drive is not detected by the DVR | <ul style="list-style-type: none"> Hard drive cables are loose or not properly connected | <ul style="list-style-type: none"> Remove the housing and check that hard drive cables are firmly connected |
| | <ul style="list-style-type: none"> There is no hard drive in the system | <ul style="list-style-type: none"> Install a 3.5" SATA hard drive using the instructions in "Appendix F: Replacing the Hard Drive" on page 114. |
| <ul style="list-style-type: none"> Hard drive is full (100%) and the unit is no longer recording | <ul style="list-style-type: none"> Overwrite is not enabled | <ul style="list-style-type: none"> Click Menu→Record→Record Mode and select . This enables the system to continuously record by overwriting data once the hard drive is full |
| <ul style="list-style-type: none"> Mouse not detected by DVR | <ul style="list-style-type: none"> Mouse cable is not firmly connected to the DVR | <ul style="list-style-type: none"> Firmly connect the mouse cable to one of the USB ports |
| | <ul style="list-style-type: none"> Mouse is not detected by the DVR | <ul style="list-style-type: none"> Disconnect the mouse and reconnect it |
| | <ul style="list-style-type: none"> DVR needs to be reset | <ul style="list-style-type: none"> Power off the DVR (disconnect power cable). Firmly connect a USB mouse to the USB port on the rear panel of the system. Reconnect the power cable to the DC 12V port on the rear panel |

Troubleshooting (Continued)

| Error | Possible Causes | Solutions |
|--|--|---|
| <ul style="list-style-type: none"> There is no picture on the monitor/TV after connecting it to the DVR | <ul style="list-style-type: none"> Monitor/TV not detected by DVR | <ul style="list-style-type: none"> Power off the monitor and DVR. Power off the monitor and DVR. Power on the monitor/TV, and then power on the DVR |
| | <ul style="list-style-type: none"> Input channel for DVR not selected on monitor/TV | <ul style="list-style-type: none"> On the monitor/TV, select the input channel the DVR is connected to |
| | <ul style="list-style-type: none"> Video cable is loose or has become disconnected | <ul style="list-style-type: none"> Check the video cable connection to the DVR and monitor/TV |
| | <ul style="list-style-type: none"> Monitor/TV or DVR is not powered on or is not receiving sufficient power | <ul style="list-style-type: none"> Ensure your DVR and monitor/TV are plugged in If the DVR or monitor/TV are connected through a power bar or surge protector, try bypassing the bar and connecting the power adapter directly to the wall outlet Confirm that there is power at the outlet: <ul style="list-style-type: none"> Connecting the power cable to another outlet Test the outlet with another plugged device (such as a lamp or phone charger) |
| | <ul style="list-style-type: none"> Video-out Resolution set to incorrect setting | <ul style="list-style-type: none"> This may occur if you have manually changed the resolution setting from the Auto setting and then connected the DVR to a different monitor/TV that is incompatible with the new setting (for example, connecting the DVR to an HDTV rather than a VGA monitor/TV) Connect the DVR to another monitor/TV. Then click Menu→Setup→Video-Out Setup→Video-Out Resolution and select Auto. Click Video-Out Update and Yes to confirm. Then power off the DVR, connect it to the desired monitor/TV, and power on the monitor/TV then the DVR |
| <ul style="list-style-type: none"> Touch Screen monitor not detected by DVR | <ul style="list-style-type: none"> USB cable for the touch screen operation has not been connected | <ul style="list-style-type: none"> Connect a USB cable from the monitor to one of the USB ports |
| | <ul style="list-style-type: none"> USB cable for the touch screen monitor has not been detected | <ul style="list-style-type: none"> Disconnect the USB cable from the DVR and reconnect it Connect the USB cable to a different USB port on the DVR With the USB cable connected, power off the monitor and DVR. Power on the monitor, and then power on the DVR. |
| <ul style="list-style-type: none"> Menu Bar or camera titles "cut-off" on TV connected with HDMI | <ul style="list-style-type: none"> Adjust the HDMI Screen Size | <ul style="list-style-type: none"> Click Menu or press  on the front panel of the DVR, and then select Setup→Video-Out Setup. Click HDMI Screen Size and scroll up / down to adjust. Right-click to exit and save changes |

Troubleshooting (Continued)

| Error | Possible Causes | Solutions |
|--|--|---|
| <ul style="list-style-type: none"> There is no picture on selected channels / camera picture is not being displayed | <ul style="list-style-type: none"> Camera cables are loose or have become disconnected | <ul style="list-style-type: none"> Check the camera power/video cable and connections Disconnect and reconnect the cable at the system and at the camera Try moving the camera to another channel or use another cable |
| | <ul style="list-style-type: none"> Camera Covert setting may be enabled | <ul style="list-style-type: none"> For details, see "Configuring the Covert Setting (Hidden Cameras)" on page 31 |
| <ul style="list-style-type: none"> Camera appears twice during split-screen viewing | <ul style="list-style-type: none"> Camera may have been accidentally assigned to the wrong channel | <ul style="list-style-type: none"> For details on camera assignment, see "Flexible Camera Assignment (Swipe-to-Switch)" on page 17 |
| <ul style="list-style-type: none"> The image on the DVR appears, but does not have sound | <ul style="list-style-type: none"> Audio-enabled camera has not been connected to the DVR | <ul style="list-style-type: none"> An audio-enabled camera is required for the DVR to play sound Connect the camera audio cable to the AUDIO port on the rear panel of the DVR. Then click Menu→Record→Video Frame Rate→Audio and scroll up/down to select the channel your camera is connected to. Right-click to save changes |
| | <ul style="list-style-type: none"> Audio channel has not been selected for audio-enabled camera | <ul style="list-style-type: none"> Click Menu→Record→Video Frame Rate→Audio and scroll up/down to select the channel your camera is connected to. Right-click to save changes |
| | <ul style="list-style-type: none"> Channel with audio-enabled camera is not selected in full-screen | <ul style="list-style-type: none"> Audio will only play when the channel with the audio-enabled camera is selected in Full-screen / Single Camera view. Double-click the channel for the audio-enabled camera to open in Full-screen / Single Camera view |
| | <ul style="list-style-type: none"> Audio cables are loose or have been disconnected | <ul style="list-style-type: none"> Check the AUDIO IN connection to the DVR |
| | <ul style="list-style-type: none"> Volume on external speakers (not included) is low or off | <ul style="list-style-type: none"> Increase volume on external speakers (not included) |
| | <ul style="list-style-type: none"> New camera titles do not appear on the system | <ul style="list-style-type: none"> New camera titles have not been applied to the DVR |
| <ul style="list-style-type: none"> Camera title display on the system is set to numerals or disabled | | <ul style="list-style-type: none"> Check the Configurations: Main Menu>Camera>Camera Title Type and scroll up / down to select CH 1 |
| <ul style="list-style-type: none"> I am not receiving email notifications | <ul style="list-style-type: none"> Email notification is disabled | <ul style="list-style-type: none"> For instructions on enabling email notifications, see "Configuring Email Alerts" on page 70 |
| | <ul style="list-style-type: none"> Motion Detection is not enabled. Email alerts are only sent when Motion Detection is triggered | <ul style="list-style-type: none"> For instructions on enabling motion detection, see "Enabling / Disabling Motion Detection" on page 40 |

Troubleshooting Remote Connections

| Error | Possible Causes | Solutions |
|---|--|---|
| <ul style="list-style-type: none"> Cannot connect to the DVR on a local network | <ul style="list-style-type: none"> DVR not connected to router | <ul style="list-style-type: none"> Connect an Ethernet cable from the DVR LAN port to your router, then disconnect and reconnect the power adapter from the DC 12V port on the DVR |
| | <ul style="list-style-type: none"> DVR and computer not on same network | <ul style="list-style-type: none"> Ensure your DVR and computer are connected to the same router If your computer is using a WiFi network, try connecting it to the router using an Ethernet cable |
| <ul style="list-style-type: none"> Cannot connect to the DVR over the Internet | <ul style="list-style-type: none"> HTTP port not port forwarded | <ul style="list-style-type: none"> Port Forward the HTTP port (default: 80) on your router. For details, see the Easy Connect Wizard manual on the CD or the reference guides on www.lorextechnology.com |
| | <ul style="list-style-type: none"> HTTP port blocked by Internet Service Provider (ISP) | <ul style="list-style-type: none"> Change the HTTP port to any port 1026 or higher, OR contact your ISP to determine which ports are available in your area, and port forward your router for the selected port |
| | <ul style="list-style-type: none"> DDNS account not created | <ul style="list-style-type: none"> Follow the instructions under "Step 2 of 4: Create a DDNS Account" on page 55 |
| | <ul style="list-style-type: none"> DDNS not enabled on DVR | <ul style="list-style-type: none"> Follow the instructions under "Step 3 of 4: Enable DDNS on the DVR" on page 59 |
| | <ul style="list-style-type: none"> DDNS address not entered correctly | <ul style="list-style-type: none"> If using client software, enter the Domain Name/URL Request you received in the confirmation email, followed by <code>.lorexddns.net</code> (for example, <code>tomsmith.lorexddns.net</code>) If using an internet browser, enter <code>http://</code>, the Domain Name/URL Request from the confirmation email in full, followed by <code>.lorexddns.net</code>, colon, and HTTP port (for example, <code>http://tomsmith.lorexddns.net:80</code>) |
| <ul style="list-style-type: none"> Cannot connect to the DVR using a mobile device | <ul style="list-style-type: none"> DVR has not been configured for Internet connection | <ul style="list-style-type: none"> Ensure you have followed all the steps in "Setting up your DVR for Remote Connectivity" on page 51. See above to troubleshoot remote connections |
| | <ul style="list-style-type: none"> IP address used from outside internal network | <ul style="list-style-type: none"> Use the DDNS address to connect to the DVR using a mobile application |
| | <ul style="list-style-type: none"> Router is blocking DDNS connection from internal network | <ul style="list-style-type: none"> Turn off WiFi connection and attempt to connect using 3G or mobile network |

EXPAND AND CUSTOMIZE YOUR SYSTEM WITH A FULL RANGE OF CAMERAS & ACCESSORIES



Specialty Cameras



Wireless Cameras



Dome Cameras



Digital Video Recorders



Monitors



Simulated Cameras



Security Hard Disc Drives



Extension Cables



Accessories

www.lorextechnology.com

1-888-42-LOREX (1-888-425-6739)

Free Manuals Download Website

<http://myh66.com>

<http://usermanuals.us>

<http://www.somanuals.com>

<http://www.4manuals.cc>

<http://www.manual-lib.com>

<http://www.404manual.com>

<http://www.luxmanual.com>

<http://aubethermostatmanual.com>

Golf course search by state

<http://golfingnear.com>

Email search by domain

<http://emailbydomain.com>

Auto manuals search

<http://auto.somanuals.com>

TV manuals search

<http://tv.somanuals.com>