

T ECHNICAL INFORMATION



PRODUCT

P 1 / 9

Model No. ▶ BUH550/ BUH650

Description ▶ Cordless Hedge Trimmers 550, 650mm (21-5/8, 25-1/2")

CONCEPT AND MAIN APPLICATIONS

Models BUH550 and BUH650 are cordless hedge trimmers powered by 36V/ 2.6Ah Li-ion battery.

Their main benefits are:

- Environment-friendly with zero emission and minimum noise pollution
- Almost zero-maintenance cost with rechargeable Li-ion battery
- 5 position rotating rear handle makes vertical and angled trimming easier and faster.
- Well balanced tool design for reduced stress on the arm and hand holding loop handle

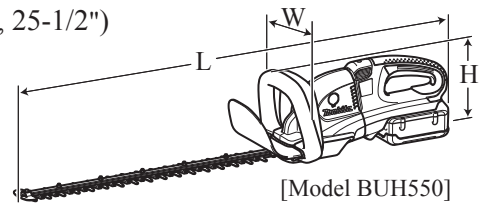

Dimensions: mm (")		
	BUH550	BUH650
Length (L)	1,070 (42)	1,150 (45-1/4)
Width (W)	220 (8-5/8)	
Height (H)	190 (7-1/2)	

These products will be available in the following variations:

Model No.		Battery		Battery cover	Charger	Battery adapter
		type	quantity			
BUH550Z	BUH650Z	No	No	No	No	No
BUH550RD	BUH650RD	BL3626	1	No	DC36RA	No
BUH550RDP	BUH650RDP					BAP36N
BUH550RDE	BUH650RDE	BL3626	2	1	DC36RA	No
BUH550RDEP	BUH650RDEP					BAP36N

All models also include the accessories listed below in "Standard equipment".

► Specification

Specification		Model	BUH550	BUH650
Battery	Cell		Li-ion	
	Voltage: V		36V	
	Capacity: Ah		2.6	
	Charging time (approx.): min.		22 with DC36RA	
Max output (W)			320	
Blade length: mm (")			550 (21-5/8)	650 (25-1/2)
No load speed: min-1=spm*1			1,000 - 1,800	
Electric brake			Yes	
Soft start			Yes	
Weight according to EPTA-Procedure 01/2003*2: kg (lbs)			5.1 (11.2)	5.2 (11.5)

*1: spm= strokes per minute

*2: with battery, shear blade assembly

► Standard equipment

Blade cover 1

Also see the product variation list above.

Note: The standard equipment for the tool shown above may vary by country.

► Optional accessories

Shear blade assembly set

Blade cover

Arm band complete set

Chip receiver assembly set

Battery BL3626

Fast charger DC36RA

Battery adaptor BAP36N

► Repair

CAUTION: Repair the machine in accordance with “Instruction manual” or “Safety instructions”.

[1] NECESSARY REPAIRING TOOLS

Code No.	Description	Use for
1R269	Bearing extractor	Removing Ball bearings

[2] LUBRICATIONS

Apply the following lubricant to the pointed area with the triangles to protect parts and product from unusual abrasion.

Item No.	Description	Portion to lubricate	Lubricant	Amount
③⑤	Gear housing complete	Gear room where ④④ Gear complete rotates	Makita grease N No.2	8g
④④	Gear complete	Crank portion for Shear blade assembly		3g
⑥	Handle L complete	Rivet 2	ISOFLEX NB52	a little

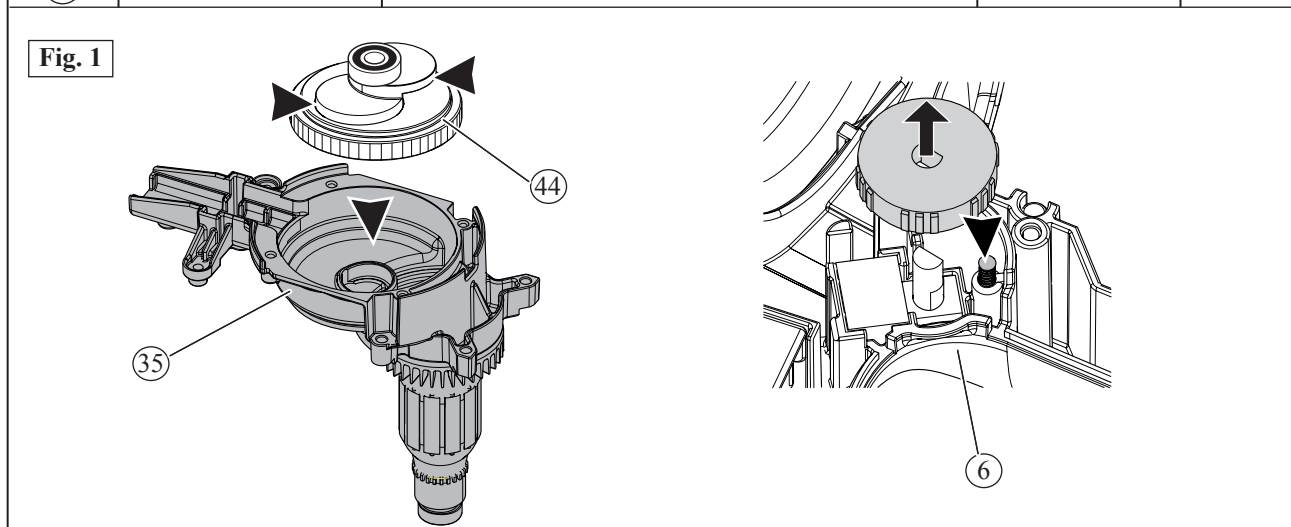

[3] DISASSEMBLY/ASSEMBLY

[3]-1. Shear Blade Assembly, Gear Complete

DISASSEMBLING

(1) Disassemble Shear blade assembly. (Figs. 2, 3)

Fig. 2

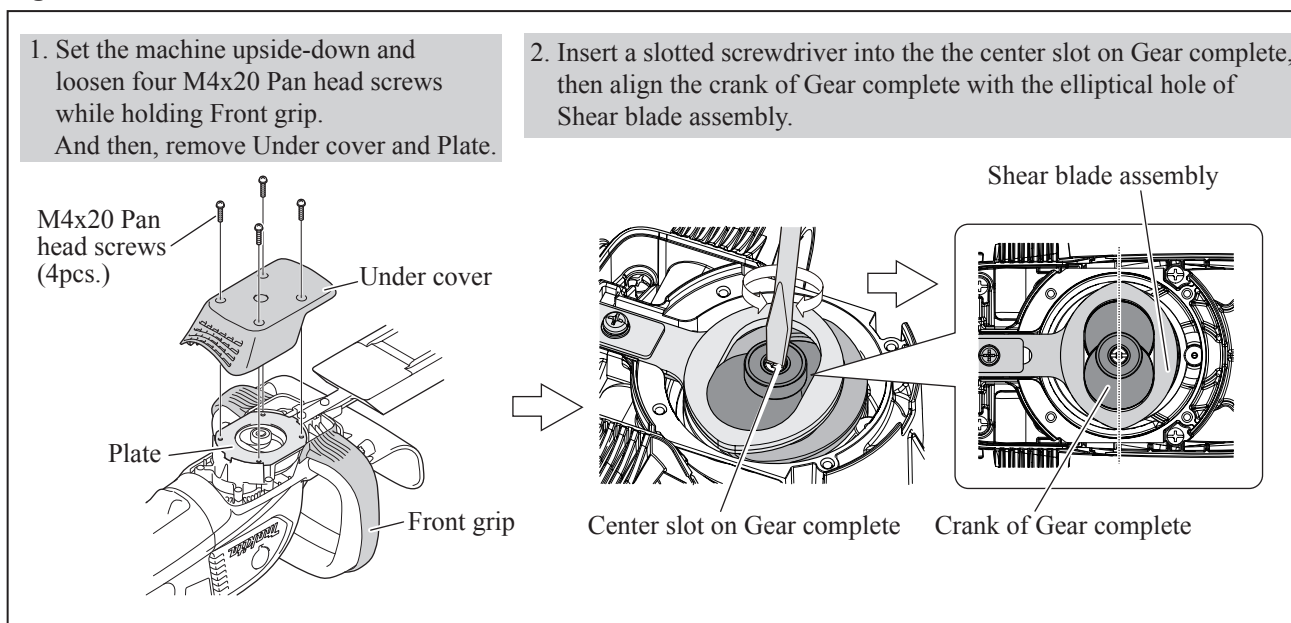

► **Repair**

[3] DISASSEMBLY/ASSEMBLY

[3]-1. Shear Blade Assembly, Gear Complete (cont.)

DISASSEMBLING

Fig. 3

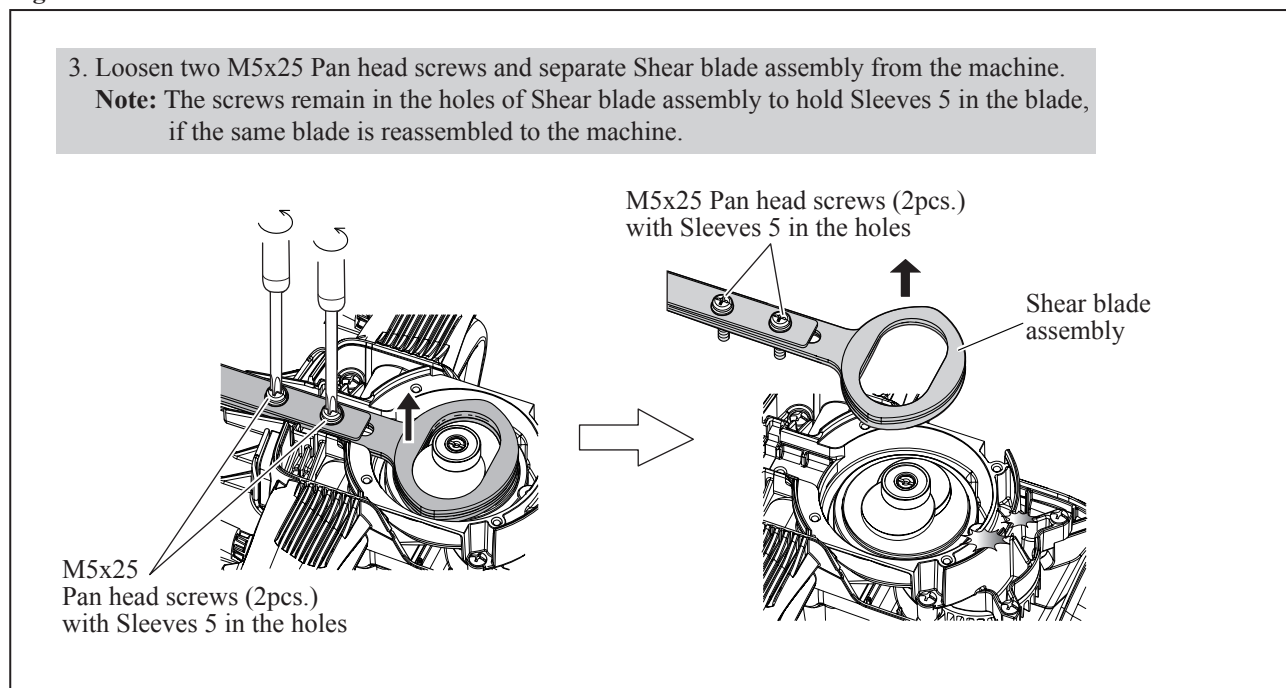

(2) Disassemble Gear complete. (**Fig.4**)

Fig. 4

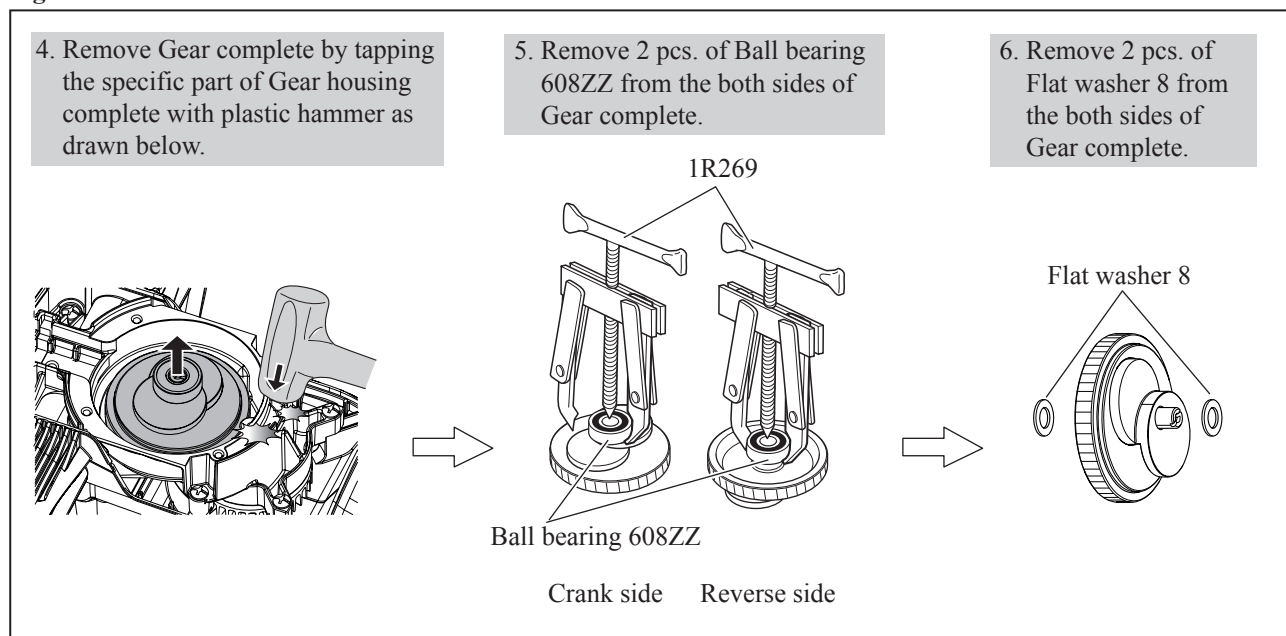

► Repair

[3] DISASSEMBLY/ASSEMBLY

[3]-1. Shear Blade Assembly, Gear Complete (cont.)

ASSEMBLING

- (1) Assemble Flat washer 8 and Ball bearing 608ZZ to the both sides of Gear complete. And then, mount Gear complete to the machine. (Fig. 4)
- (2) Assemble Shear blade assembly. (Fig. 5)

Fig. 5

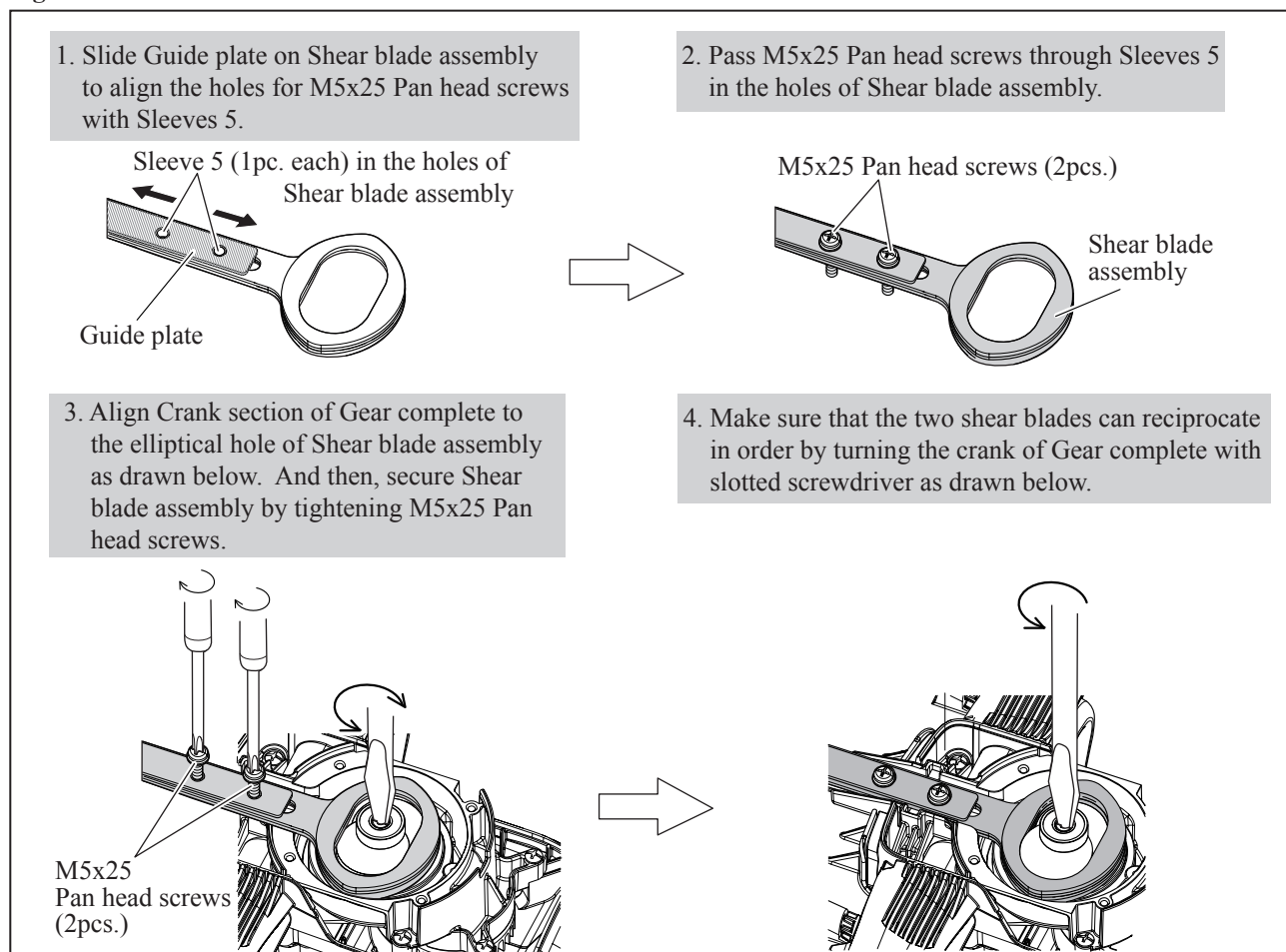

[3]-2. Armature, Switch

DISASSEMBLING

- (1) Disassemble Shear blade assembly. (Figs. 2, 3)
- (2) Disassemble Gear complete. (Fig.4)
- (3) Remove Carbon brushes. And separate Gear housing complete. (Fig. 6)

Fig. 6

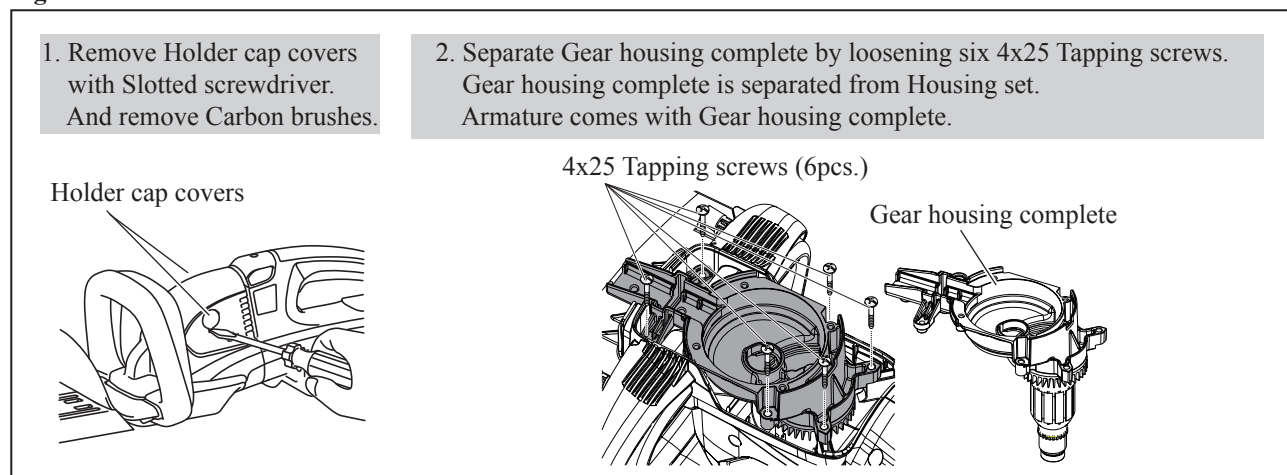

► **Repair**

[3] DISASSEMBLY/ASSEMBLY

[3]-2. Armature, Switch (cont.)

DISASSEMBLING

(3) Remove Armature and Ball bearings. (Fig. 7)

Fig. 7

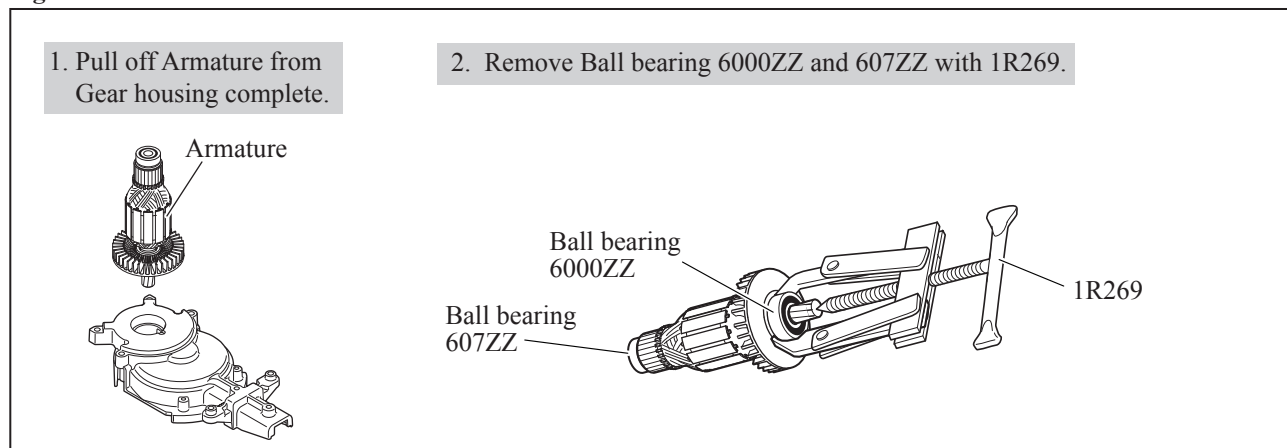

(4) Replace switches. (Fig. 8)

Fig. 8

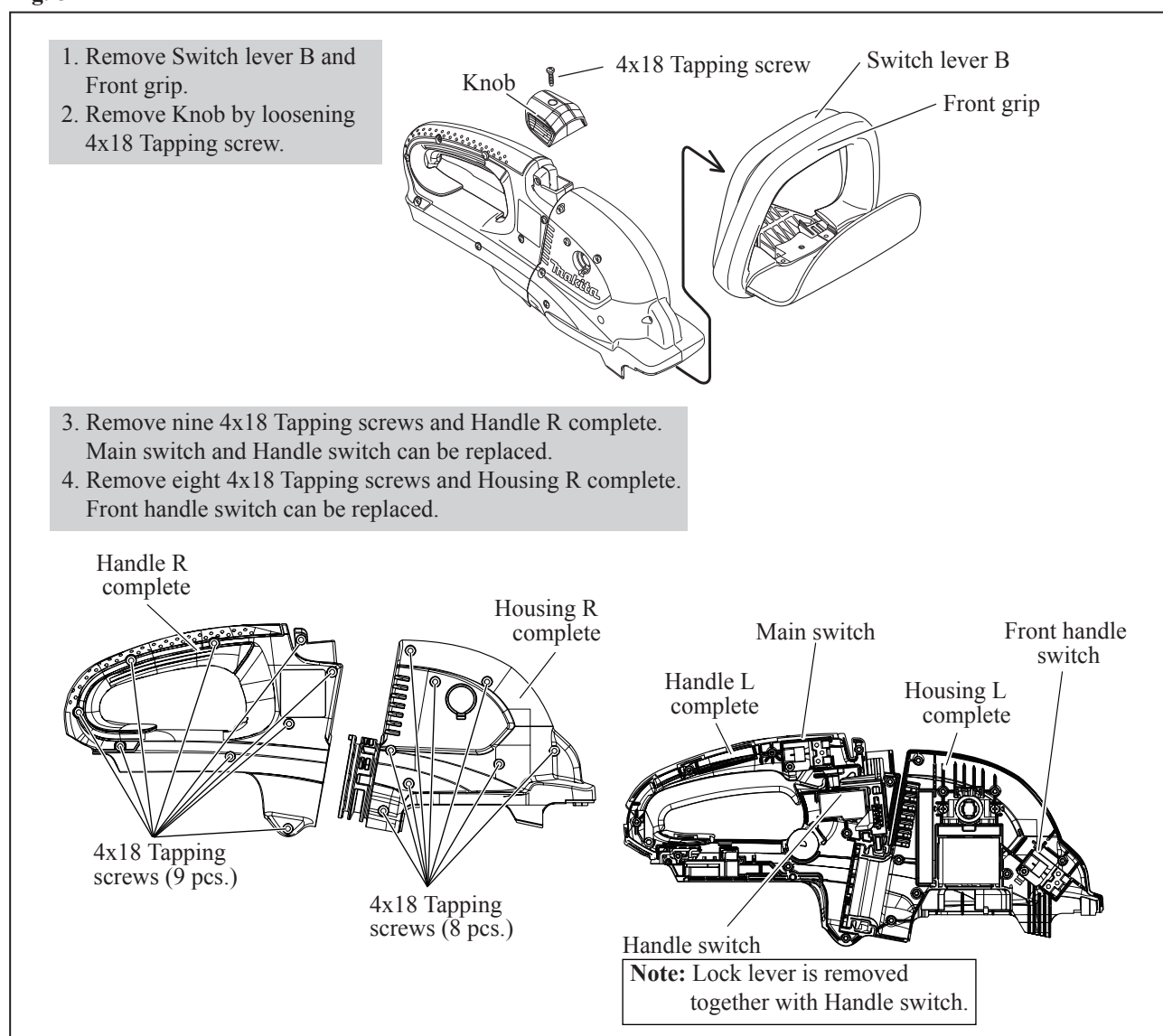

► Repair

[3] DISASSEMBLY/ASSEMBLY

[3]-2. Armature, Switch (cont.)

ASSEMBLING

- (1) Mount the Switches to Handle L complete and Housing L complete by taking the reverse step of Disassembling. (Fig. 8)
- (2) Armature can be assembled by taking the reverse step of Disassembling. (Figs. 7, 6)
- (3) Assemble Gear complete. (Fig. 4) And then, mount Shear blade assembly. (Figs. 3, 2)

[3]-3. Lock Lever

ASSEMBLING

Reassemble Lock lever. (Fig. 9)

Fig. 9

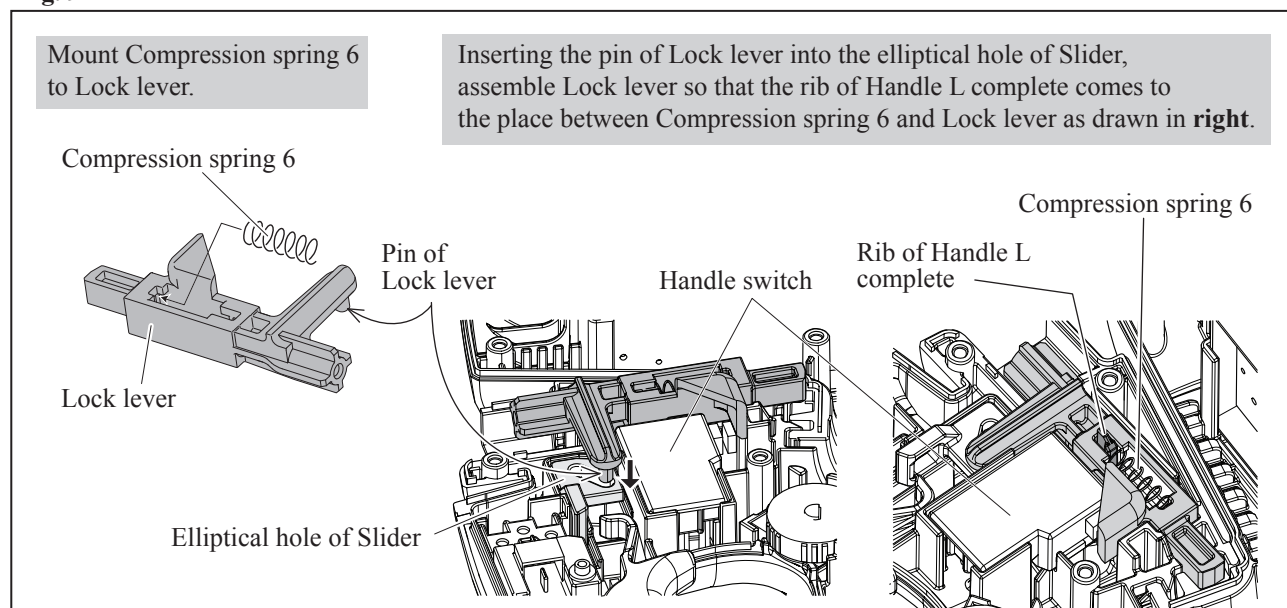

[3]-4. Yoke Unit

ASSEMBLING

Assemble Yoke unit to Housing L complete. (Fig. 10)

Fig. 10

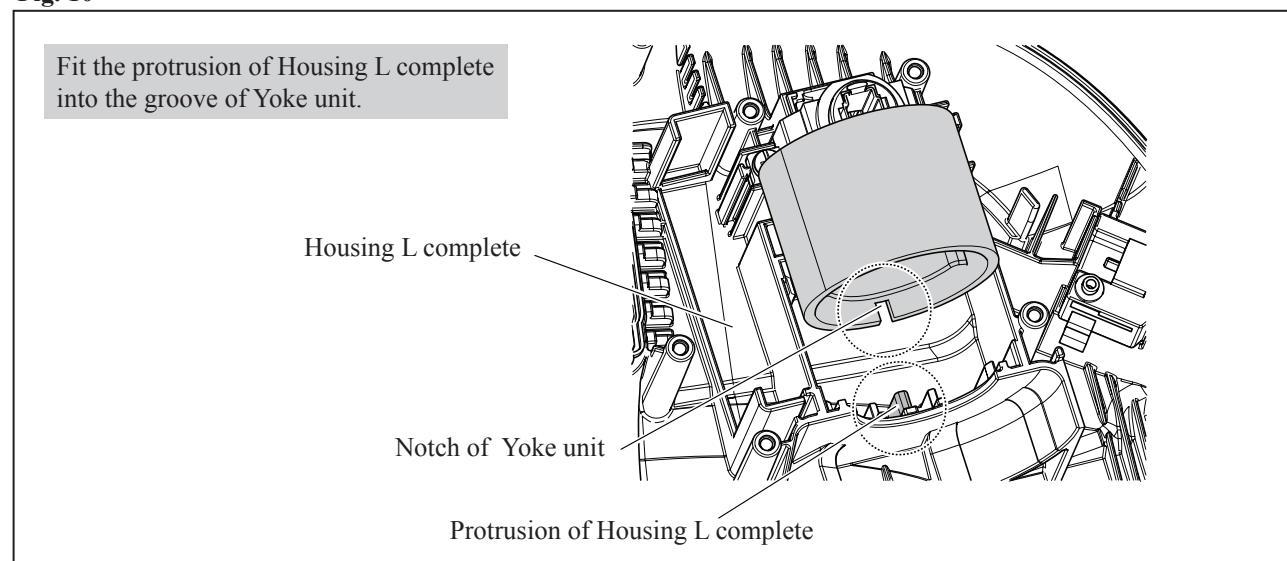

► **Circuit diagram**

Fig. D-1

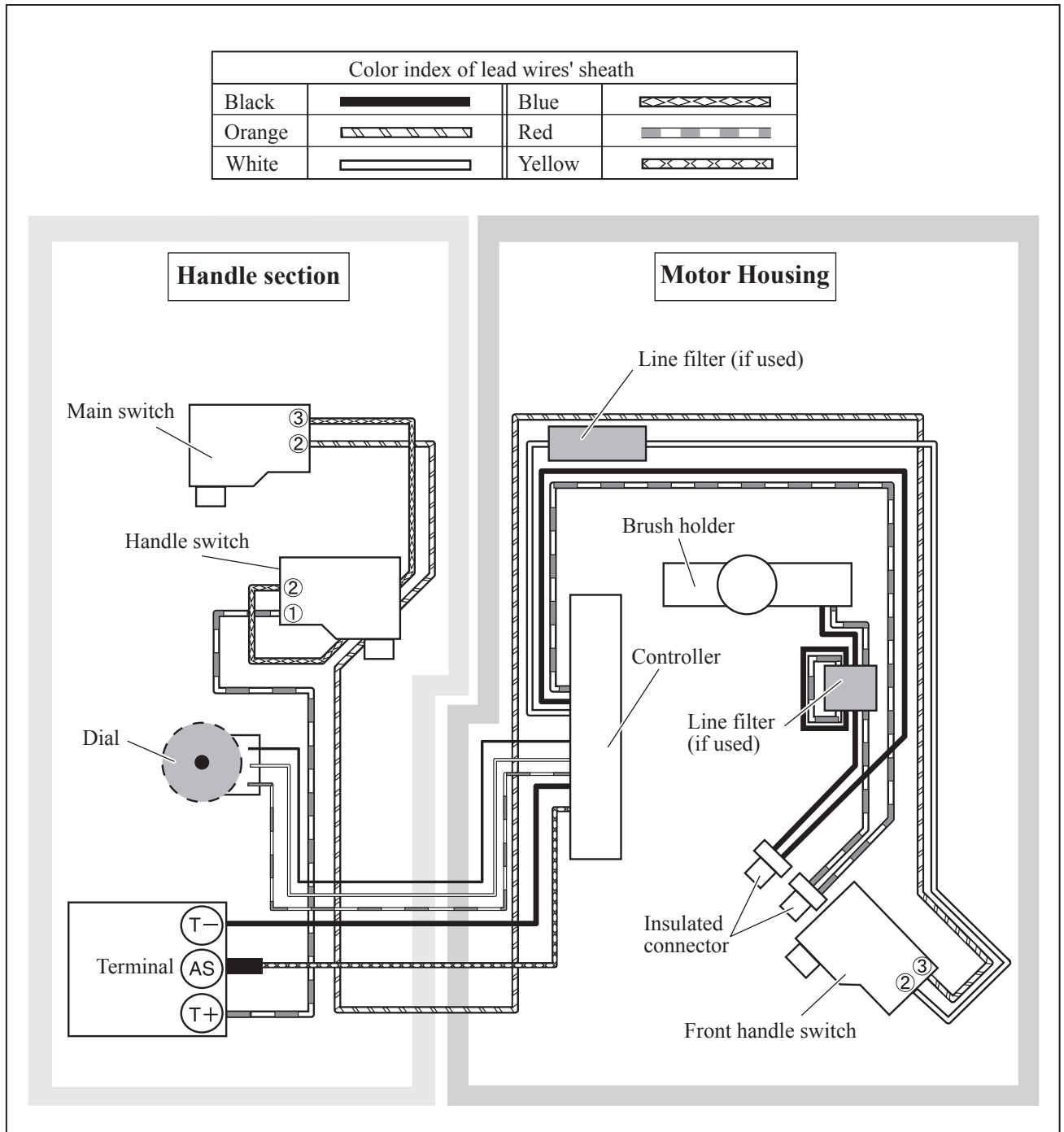

► **Wiring diagram**

Fig. D-2

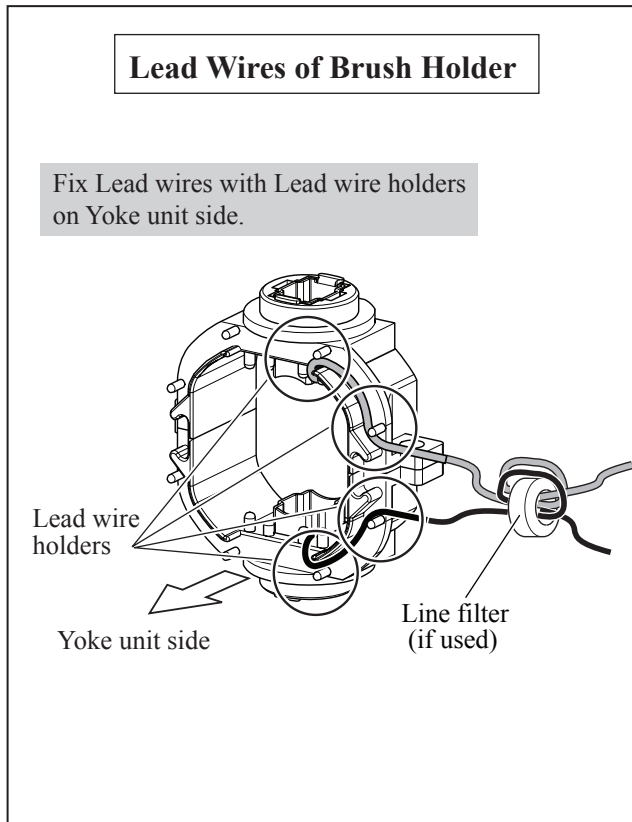

Fig. D-3

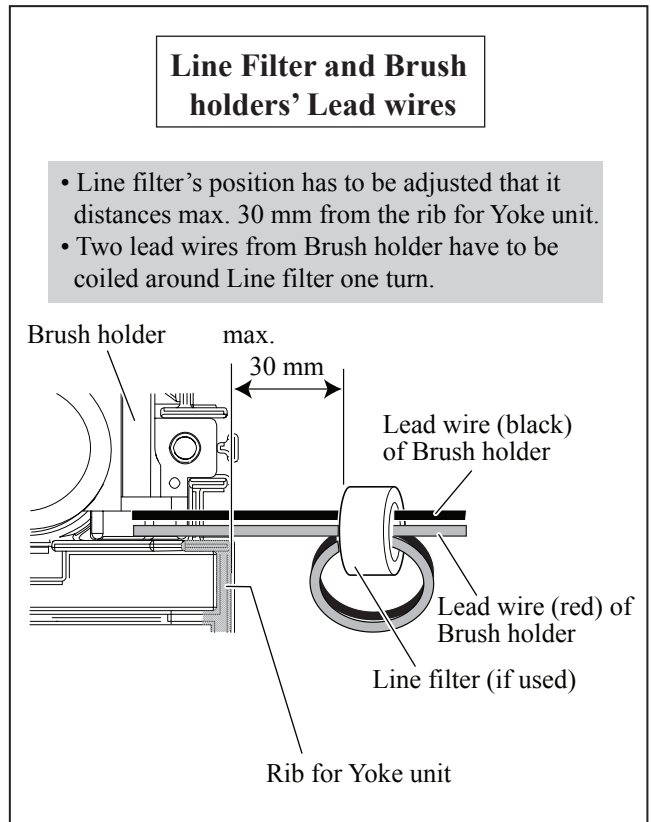
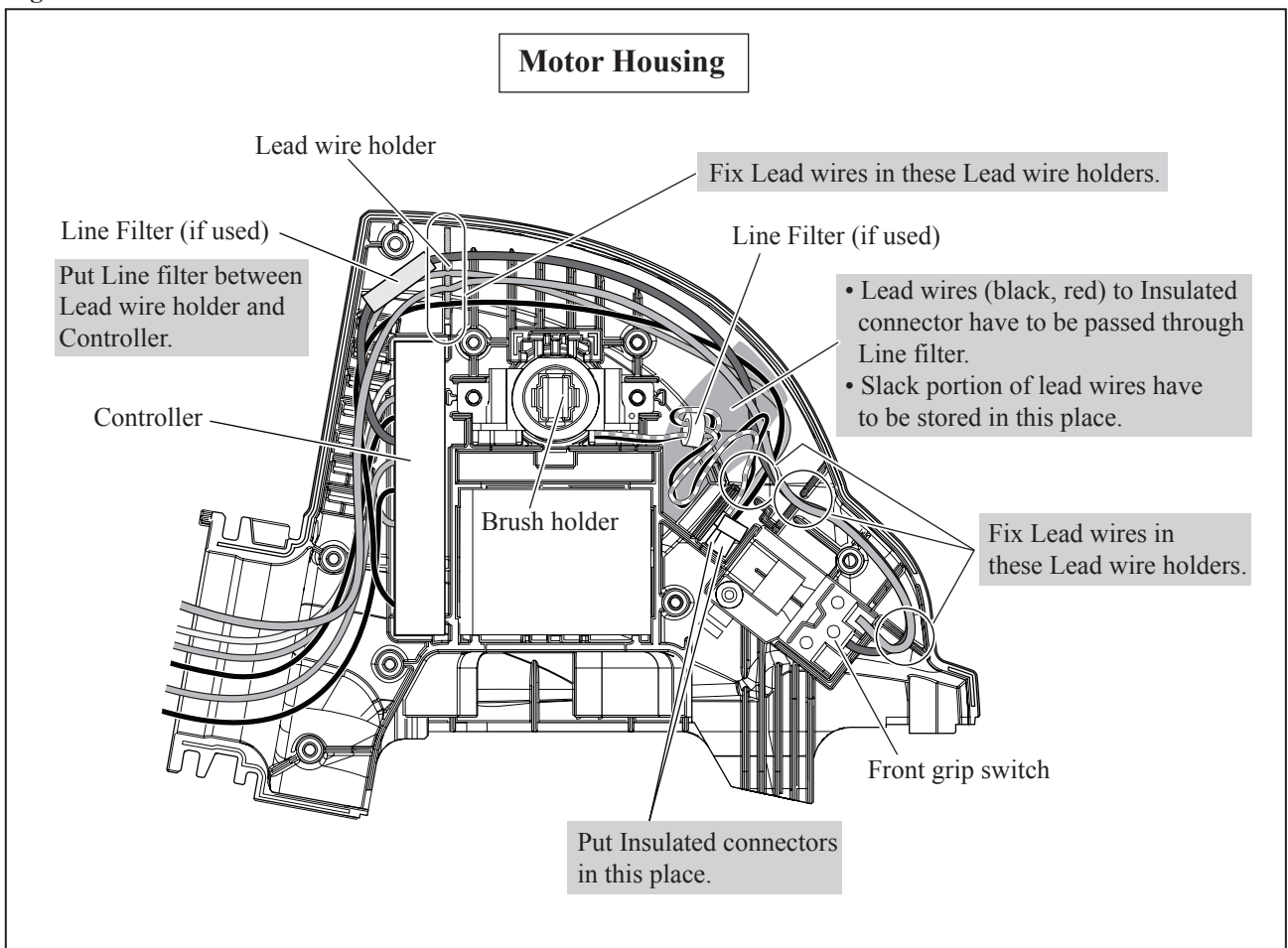

Fig. D-4



► **Wiring diagram**

Fig. D-5

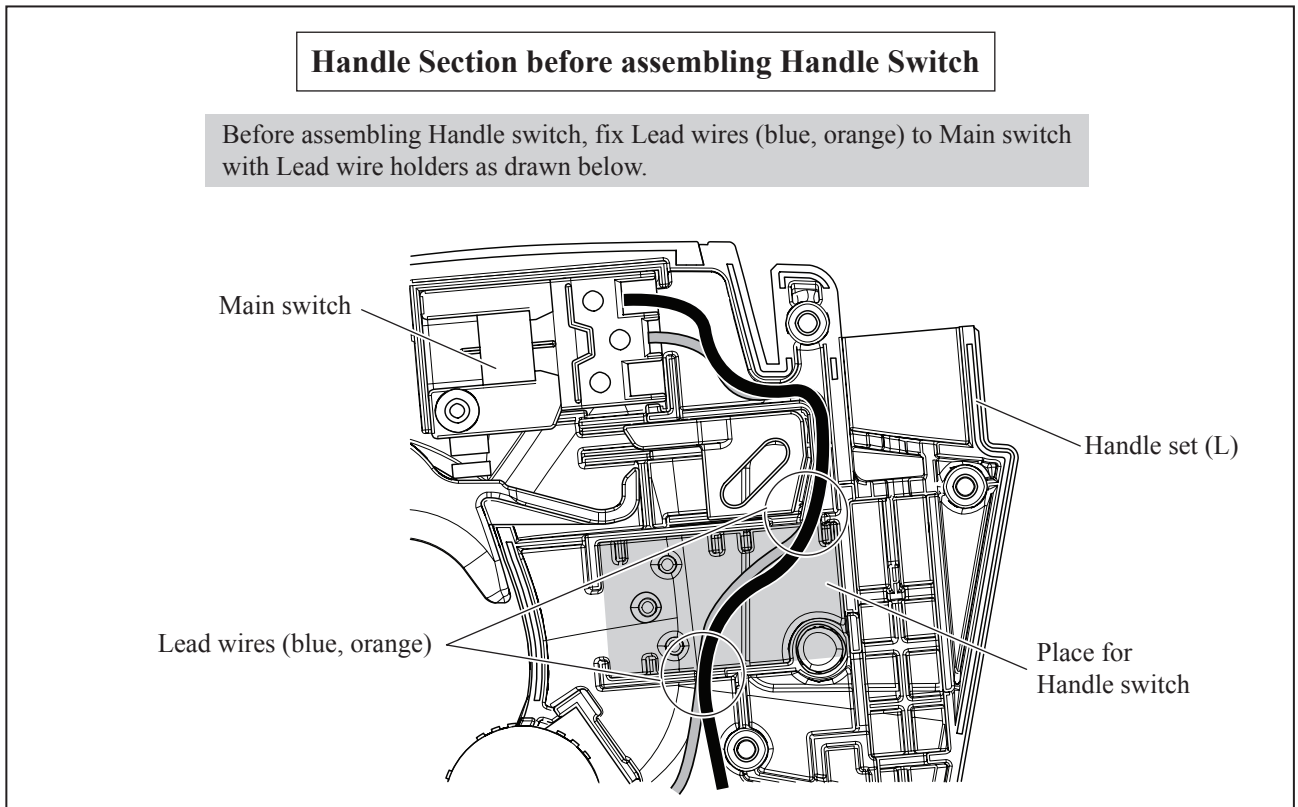
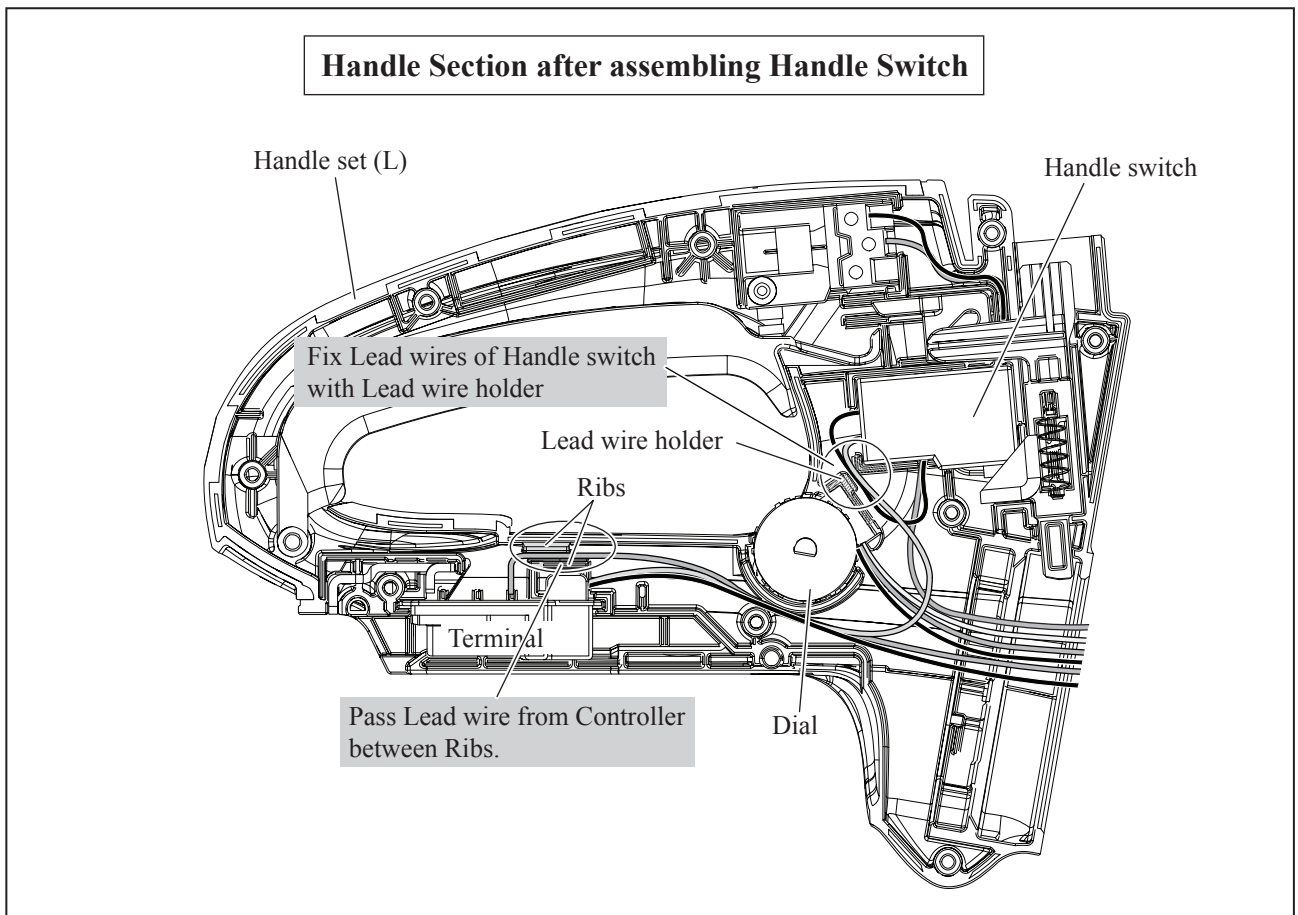

Fig. D-6



Free Manuals Download Website

<http://myh66.com>

<http://usermanuals.us>

<http://www.somanuals.com>

<http://www.4manuals.cc>

<http://www.manual-lib.com>

<http://www.404manual.com>

<http://www.luxmanual.com>

<http://aubethermostatmanual.com>

Golf course search by state

<http://golfingnear.com>

Email search by domain

<http://emailbydomain.com>

Auto manuals search

<http://auto.somanuals.com>

TV manuals search

<http://tv.somanuals.com>