



## PETROL HEDGE TRIMMER

**EH5000W**

**EH6000W**

**EH7500W**

### INSTRUCTION MANUAL

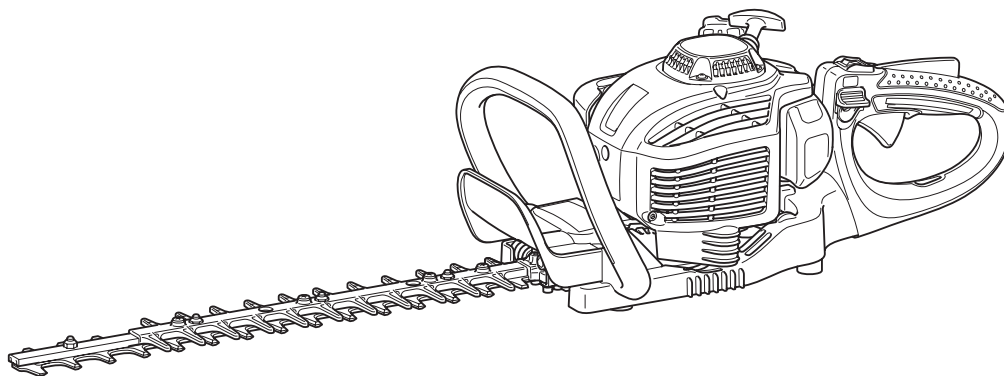

**WARNING:**

To reduce the RISK of injury, user must read and understand the instruction manual before using the hedge trimmer. Manufacturer reserves the right to change specifications without notice. Specifications may differ from country to country. Do only hand over the hedge trimmer together with this manual.

Thank you very much for selecting the MAKITA hedge trimmer. We are pleased to be able to offer you the MAKITA hedge trimmer which is the result of a long development program and many years of knowledge and experience.

The hedge trimmer models EH5000W, EH6000W and EH7500W combine the advantages of state-of-the-art technology with ergonomic design, light weight, handy, compact and represent professional equipment for a great variety of applications.

**Please read, understand and follow this booklet which refers in detail to the various points that will demonstrate its outstanding performance. This will assist you to safely obtain the best possible results from your MAKITA hedge trimmer.**

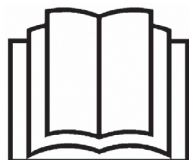

Table of Contents	Page
Symbols.....	2
Safety instructions.....	3
Technical data.....	6
Designation of parts.....	7
Fuels/refueling.....	8
Precautions before starting.....	9
Starting the machine.....	10
Stopping the machine.....	10
Operation of the machine.....	11
Adjusting rear handle angle.....	11
Maintenance instructions.....	12
Storage.....	15
Maintenance schedule.....	15
Fault location.....	15

## SYMBOLS

It is very important to understand the following symbols when reading this instructions manual.

	WARNING/DANGER		Fuel and oil mixture
	Read, Understand and Follow Instruction Manual		Engine-Manual start
	Forbidden		Emergency stop
	No smoking		First Aid
	No open flame		Recycling
	Protective gloves must be worn		ON/START
	Keep the area of operation clear of all persons and pets		OFF/STOP
	Wear eye and ear protection		

# SAFETY INSTRUCTIONS

## General Instructions

- THIS MACHINE CAN CAUSE SERIOUS INJURIES. Read the Instructions carefully for correct handling, preparation, maintenance, starting and stopping of the machine. Be familiar with all controls and the proper use of the machine. (1)
- It is recommended only to loan the hedge trimmer to people who have proven to be experienced with hedge trimmers. Always hand over the instruction manual.
- First-time users should ask the dealer for basic instructions to familiarize themselves with handling of an engine powered hedge trimmer.
- Children and young persons aged under 18 years must not be allowed to operate the hedge trimmer. Persons over the age of 16 years may however use the device for the purpose of being trained only while under the supervision of a qualified trainer.
- Use the hedge trimmer with the utmost care and attention.
- Operate the hedge trimmer only if you are in a good physical condition. Perform all work calmly and carefully. The user has to accept liability for others.
- Never use the hedge trimmer after consuming alcohol or drugs, or if feeling tired or ill. (2)

## Intended use of the machine

- The hedge trimmer is designed for only the purpose of trimming bushes and hedges, and must not be used for any other purpose. Do not abuse the Trimmer.

## Personal protective equipment

- The clothing worn should be functional and appropriate, i.e. it should be tight-fitting but not cause hindrance. Do not wear jewelry or loose clothing which could become entangled with bushes or shrubs, or the machine.
- In order to avoid eye, hand or foot injuries as well as to protect your hearing, the following protective equipment and protective clothing must be used during operation of the hedge trimmer.
- During operation of the hedge trimmer always wear goggles or a visor to prevent eye injuries. (3)
- Wear adequate noise protection equipment to avoid hearing impairment, ear muffs, ear plugs, etc. (3)
- We strongly recommend that the user wears work overalls. (4)
- Special gloves made of thick leather are part of the prescribed equipment and must always be worn during operation of the hedge trimmer. (4)
- When using the hedge trimmer, always wear sturdy shoes with a non-slip sole. This protects against injuries and ensures a good footing. (4)

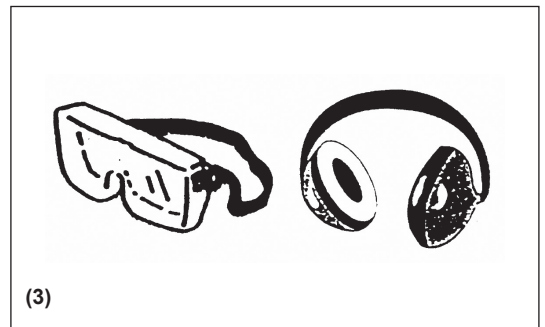
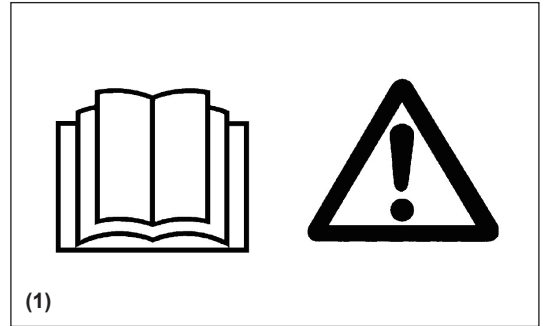

## Starting up the hedge trimmer

- Please make sure that there are no children or other people within a working range of 15 meters (5), also pay attention to any animal in the working vicinity.
- Before operating, always check the hedge trimmer is safe for operation.
- Check the security of the throttle lever. The throttle lever should be checked for the smooth and easy actions. Check for proper functioning of the throttle lever lock. Check for clean and dry handles and test the function of the I-O switch. Keep handles free of oil and fuel.

Start the hedge trimmer only in accordance with the instructions.

### Do not use any other methods for starting the engine (6)!

- Use the hedge trimmer only for applications specified.
- Start the hedge trimmer engine only after the entire assembly is done. Operation of the hedge trimmer is permitted only after all the appropriate accessories are attached!
- Before starting, make sure that the cutter blade will not contact any objects such as branches, stones, etc.
- Stop the engine immediately if there are any engine problems.
- During operation, hold both the front and rear handle firmly by wrapping your fingers around the handles. Keep handles clean and free of moisture, resin, oil or grease.

### Always ensure a safe, well-balanced footing.

- Only use outdoors.
- Always be aware of your surroundings and stay alert for possible hazards that you may not hear due to the noise of the machine.
- Operate the hedge trimmer in such a manner as to avoid inhalation of the exhaust gases. Never run the engine in enclosed rooms (risk of suffocation and gas poisoning). Carbon monoxide is an odorless gas. Always ensure there is an adequate ventilation.
- Stop the engine when resting and when leaving the hedge trimmer unattended. Place it in a safe location to prevent danger to others or, setting fire to combustible materials or damage to the machine.
- Never put the hot hedge trimmer onto dry grass or onto any combustible materials.
- To reduce fire hazard, keep the engine and silencer free of debris, leaves, or excessive lubricant.
- Never operate the engine with a faulty exhaust muffler.
- Stop the engine during transport (7).
- Stop the engine before:
  - Cleaning a blockage;
  - Checking, maintenance or working on the machine.
- Position the hedge trimmer safely during car or truck transportation to avoid a fuel leakage.
- When transporting the hedge trimmer ensure that the fuel tank is completely empty to avoid fuel leakage.
- When transporting or storing the machine always fit the cutting device guard.

## Refuelling

- Stop the engine before refuelling (7), keep well away from open flame (8) and do not smoke.
- Do not attempt to refuel a hot or a running engine.
- Avoid skin contact with petroleum products. Do not inhale fuel vapors. Always wear protective gloves during refuelling. Change and clean protective clothing at regular intervals.
- Take care not to spill either fuel or oil in order to prevent soil contamination (environmental protection). Wipe down the hedge trimmer immediately after fuel has been spilled. Dry the cloths used for wiping the fuel at a well ventilated area before disposing them. Failure to do so may cause spontaneous combustion.
- Avoid any fuel contact with your clothes. Change your clothes immediately if fuel has been spilled on it (dangerous hazard).
- Inspect the fuel cap at regular intervals making sure that it stays securely fastened.
- Carefully tighten the fuel tank cap. Change locations to start the engine (at least 3 meters away from the place of refuelling) (9).
- Never refuel in closed rooms. Fuel vapors accumulate at ground level (risk of explosions).
- Only transport and store fuels in approved containers. Make sure stored fuel is not accessible to children.
- When mixing gasoline with two-stroke engine oil, use only gasoline which contains no ethanol or methanol (types of alcohol). This will help to prevent damage to fuel lines and other engine parts.

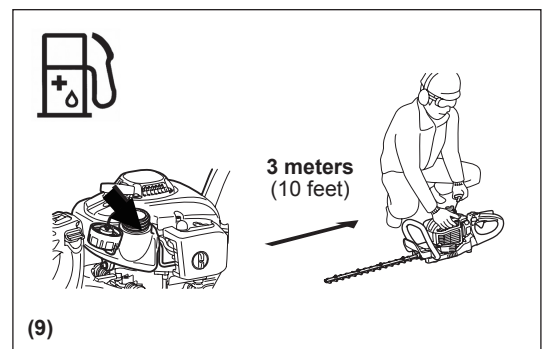
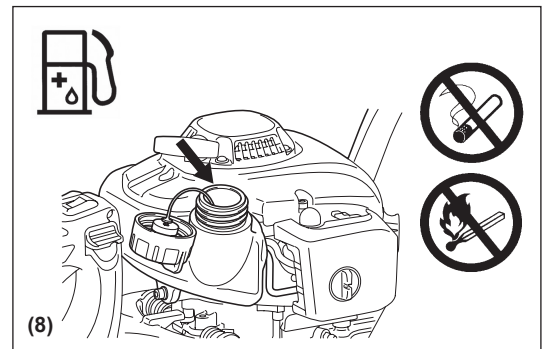
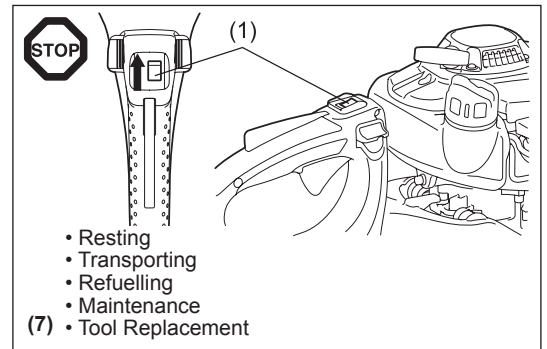
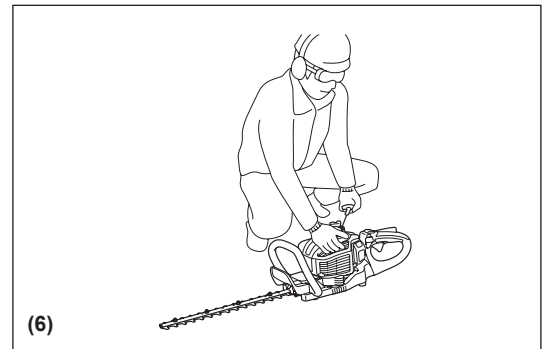
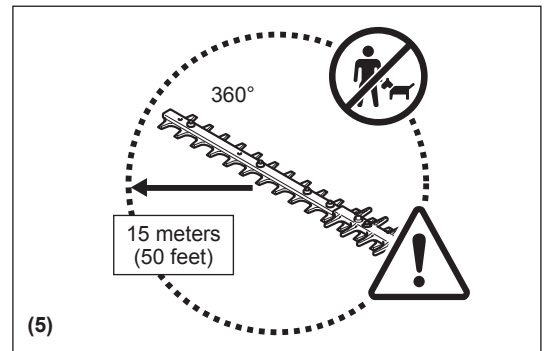

## Method of operation

- Always use two hands to grip each handle during operation.
- Use the hedge trimmer only in a good light and visibility. During cold seasons beware of slippery or wet areas, ice and snow (risk of slipping). Always ensure a safe footing.
- Never work on unstable surfaces or steep terrain.
- Never stand on a ladder and run the hedge trimmer.
- Never climb up onto trees to perform cutting operation with the hedge trimmer.
- To reduce the risk of stumbling and loss of control, do not walk backward while operating the machine.
- Always stop the engine before cleaning or servicing the unit or replacing parts.
- Do not operate the machine with a damaged or excessively worn cutting device.



## Maintenance instructions

- Be kind to the environment. Operate the hedge trimmer with as little noise and pollution as possible. In particular check the correct adjustment of the carburetor.
- Clean the hedge trimmer at regular intervals and check that all screws and nuts are securely tightened.
- Never service or store the hedge trimmer in the vicinity of open flames, sparks, etc. (11).
- Empty the fuel tank before storing the hedge trimmer.
- Never store the hedge trimmer in the vicinity of naked flames to avoid fires.
- Store the hedge trimmer in well ventilated and high or locked location out of reach of children.
- Do not attempt to repair the machine unless you are qualified to do so.

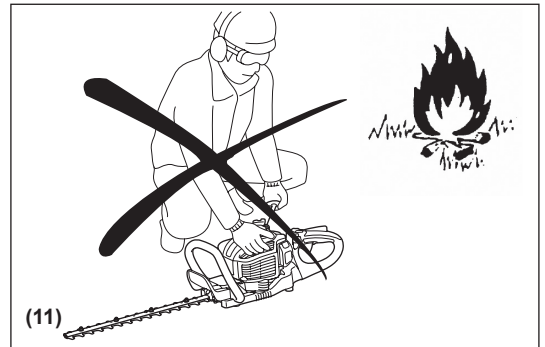

**Observe and follow all relevant accident prevention instructions issued by the trade associations safety board and by insurance companies.**

**Do not perform any modifications to the hedge trimmer as this will risk your safety.**

The performance of maintenance or repair work by the user is limited to those activities as described in this instruction manual. All other works are to be done by Authorized Service Agents.

Use only genuine spare parts and accessories supplied by MAKITA authorized or factory service centers.

Use of non-approved accessories and tools means increased risk of accidents and injuries. MAKITA will not accept any liability for accidents or damage caused by the use of any non-approved accessories.

## First aid

In case of an accident make sure that a well-stocked first-aid kit according to DIN 13164, is available in the vicinity of the cutting operations. Immediately replace any item taken from the first aid kit.

**When asking for help, please give the following information:**

- Place of accident
- What happened
- Number of injured persons
- Extend of injuries
- Your name

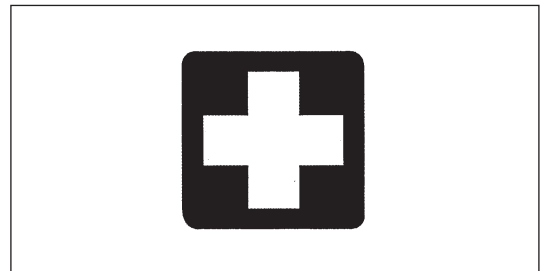

## Packaging

The MAKITA hedge trimmer is delivered in a protective cardboard box to prevent shipping damage. Cardboard is a basic raw material and is therefore consequently reusable or suitable for recycling (waste paper recycling).



## TECHNICAL DATA

Model			EH5000W	EH6000W	EH7500W	
Dimension (L x W x H)	mm		1,014 x 262 x 216	1,119 x 262 x 216	1,259 x 262 x 216	
Mass (without blade cover)	kg		4.8	5.0	5.2	
Volume (fuel tank)	L			0.4		
Engine displacement	cm <sup>3</sup>			22.2		
Cutting length	mm		483	588	728	
Maximum engine performance	kW			0.68		
Stroke per minute	min <sup>-1</sup>			4,270		
Idling speed	min <sup>-1</sup>			3,000		
Clutch engagement speed	min <sup>-1</sup>			4,000		
Carburetor type	type		WALBRO WYL			
Ignition system	type		Solid state ignition			
Spark plug	type		NGK CMR6A			
Electrode gap	mm		0.7 - 0.8			
Vibration per EN ISO 10517	Right handle	$a_{hv\ eq}$	m/s <sup>2</sup>	2.5	2.7	2.3
		Uncertainty K	m/s <sup>2</sup>	1.3	1.1	1.6
	Left handle	$a_{hv\ eq}$	m/s <sup>2</sup>	2.5	2.8	2.3
		Uncertainty K	m/s <sup>2</sup>	1.3	1.1	1.2
Noise per EN ISO 10517	Sound pressure level		dB (A)	93.0	92.8	93.9
		Uncertainty K	dB (A)	1.4	2.2	1.2
	Sound power level		dB (A)	103.0	103.2	103.8
		Uncertainty K	dB (A)	2.1	1.5	1.3
Mixture ratio (fuel: engine oil)	MAKITA genuine two-stroke engine oil			50 : 1		
	Other manufacturer's two-stroke engine oil			25 : 1		
Gear ratio				9 : 43		

## DESIGNATION OF PARTS

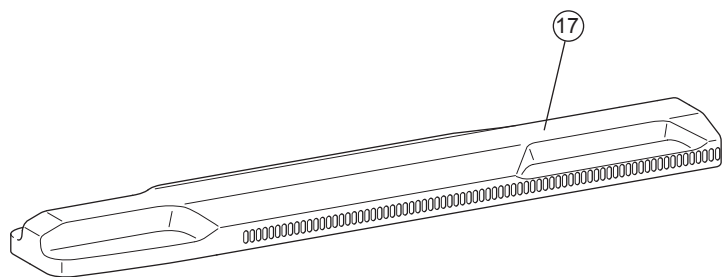
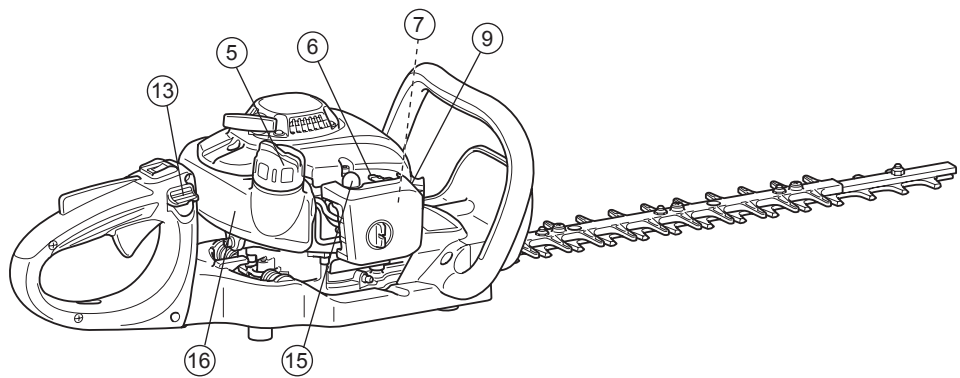
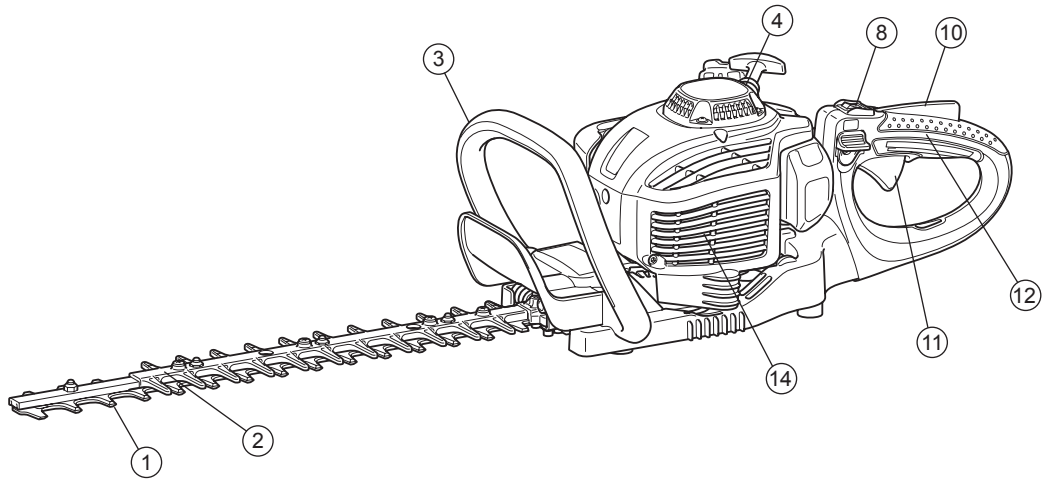

	DESIGNATION OF PARTS		DESIGNATION OF PARTS		DESIGNATION OF PARTS
1	Blade	7	Carburetor (not shown)	13	Release lever
2	Blunt extension	8	I-O switch (ON-OFF)	14	Muffler
3	Front handle	9	Spark plug	15	Primer pump
4	Recoil starter	10	Lock-off lever	16	Fuel tank
5	Fuel tank cap	11	Throttle lever	17	Blade cover
6	Choke lever	12	Rear handle		

# FUELS/REFUELING

## Fuel and oil mixture



- The engine of the hedge trimmer is a high-efficiency two-stroke engine. It is run with a mixture of fuel and two-stroke engine oil. The engine is designed for unleaded regular fuel with a min. octane value of 91 ROZ. In case no such fuel is available, you can use fuel with a higher octane value. This will not damage the engine, but may cause poor operating behaviour. A similar situation will arise from the use of leaded fuel. To obtain optimum engine operation and to protect your health and the environment, only unleaded fuel should be used!
- For lubricating the engine use a two-stroke engine oil (quality grade: TSC-3), which is added to the fuel. The engine has been designed for use with MAKITA two-stroke engine oil and a mixture ratio of 50:1 only to protect the environment. In addition, a long service life and a reliable operation with a minimum emission of exhaust gases is guaranteed. It is absolutely essential to observe a mixture ratio of 50:1 (MAKITA 2-stroke engine oil), otherwise the reliable function of the hedge trimmer cannot be guaranteed.
- The correct mixture ratio:  
Gasoline: Specified two-stroke engine oil = 50 : 1 or  
Gasoline: Other manufacturer's two-stroke engine oil = 25 : 1 recommended

**NOTE:** For preparing the fuel-oil mixture, first mix the entire oil quantity with half of the fuel required in an approved canister which meets or exceeds all local code standards. Then add the remaining fuel. Thoroughly shake the mixture before filling it into the hedge trimmer's tank. Do not add more engine oil than specified to ensure safe operation. It will only result in a higher production of combustion residues which will pollute the environment and clog the exhaust channel in the cylinder as well as the muffler. In addition, the fuel consumption will rise and the performance will decrease.

## Handling petroleum products

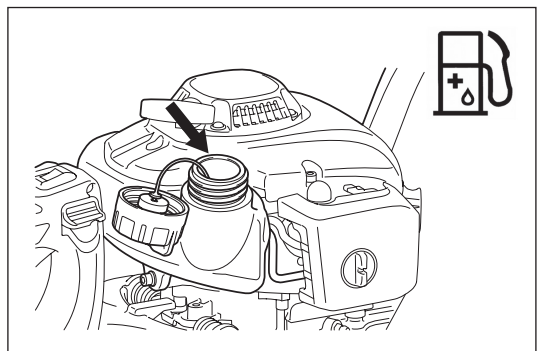
Utmost care is required when handling fuels. Fuels may contain substances similar to solvents. Refuel either in a well ventilated area or outdoors. Do not inhale fuel vapors, avoid any contact of fuel or oil with your skin. If your skin comes in contact with these substances repeatedly and for an extended period of time, it will desiccate. Various skin diseases may result. In addition, allergic reactions are known to occur. Eyes can be irritated by contact with oil, fuel etc. If oil, fuel, etc., comes into your eyes, immediately wash them with clear water. If your eyes are still irritated, see a doctor immediately!



Gasoline	+	Oil
	50:1	
	+	
	50:1	
1,000 cm <sup>3</sup> (1 liter) 5,000 cm <sup>3</sup> (5 liter) 10,000 cm <sup>3</sup> (10 liter)		20 cm <sup>3</sup> 40 cm <sup>3</sup> 100 cm <sup>3</sup> 200 cm <sup>3</sup> 200 cm <sup>3</sup> 400 cm <sup>3</sup>



## Refuelling

- The engine must be switched off.
- Stop the engine during refuelling, keep away from flames and do not smoke.
- Take care not to spill either fuel or oil in order to prevent soil contamination. Clean the hedge trimmer immediately after fuel has been spilled.
- Do not spill fuel onto the engine. Wipe down if the fuel is spilled.
- Avoid any fuel contact with your clothes. Change your clothes instantly if fuel has been spilled on it (to prevent clothes catching fire).
- Inspect the fuel cap regularly making sure that it can be securely fastened and does not leak the fuel.
- Carefully tighten the fuel tank cap. Change location to start the engine (at least 3 meters away from the place of refuelling.)
- Never refuel in closed rooms. Fuel vapors accumulate at ground level. (Risk of explosions.)
- Transport and store fuel only in approved containers. Make sure the fuel stored is not accessible to children.
- Thoroughly clean the area around the tank cap to prevent dirt from getting into the fuel tank.
- Unscrew the plug and fill the tank with fuel. Use a gauze funnel to filter the fuel.
- Tightly screw on the plug by hand only.
- Clean around the screw plug and the tank after refuelling.
- Always wipe up any spilled fuel to prevent a fire.

## Storage of fuel

- Fuel cannot be stored for an unlimited period of time.
- Purchase only the quantity required for a 4 week operation period.
- Use approved fuel storage containers only.

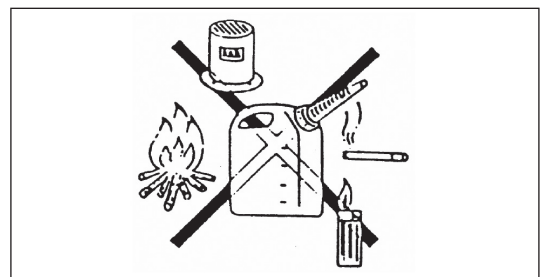
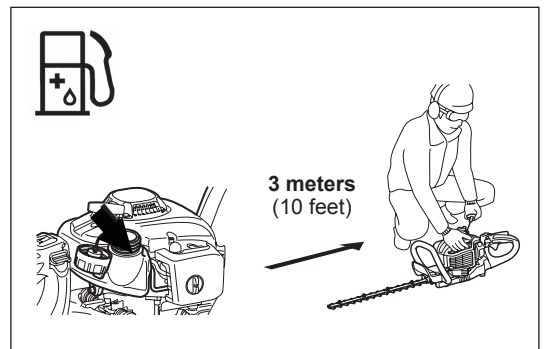
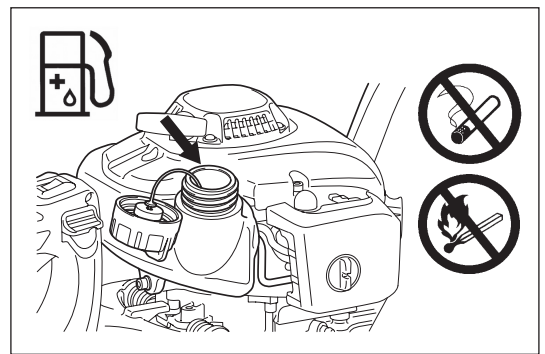

## PRECAUTIONS BEFORE STARTING

- Make sure that there are no children or other people within a working range of 15 meters. Also pay attention to any animal in the working vicinity.
- Before use always check that the hedge trimmer is safe for operation. Check the cutting device is not damaged, the control lever for easy action and check for the proper function of the I-O switch. Make sure that the cutting blades do not run when the engine is idling. Check with your dealer for adjustment if in doubt. Check for clean and dry handles and test function of the I-O switch.
- Start the hedge trimmer only in accordance with the instructions. Do not use any other methods for starting the engine. (See Starting)
- Start the engine only after the entire assembly is done. Operation of the engine is only permitted after all the appropriate accessories are attached. Otherwise there is a risk of injury.
- Before starting, make sure that the cutting blades have no contact with objects such as branches, stones, etc.
- Before trimming, inspect the area for wires, cords, glass, or other foreign objects which could come in contact with the blade.
- Electrical shock. Be aware of any and all electric lines and electric fences. Check all areas for electrical lines before cutting.

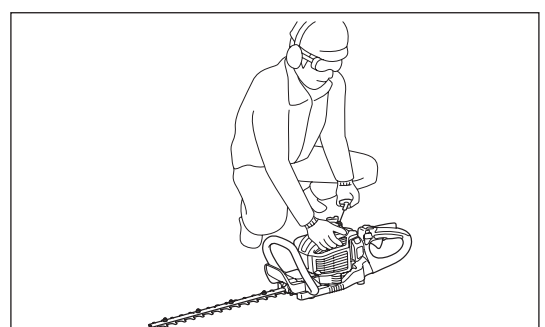
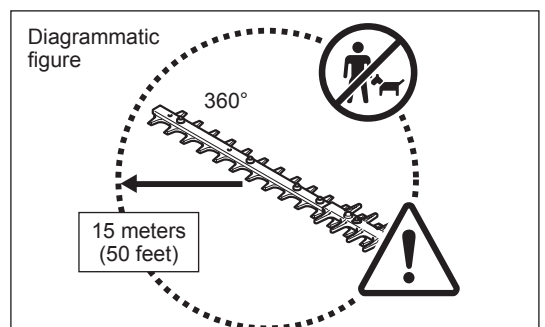

## STARTING THE MACHINE

Move at least 3 meters away from the place of refuelling. Place the hedge trimmer on a clean area of ground. Make sure that the cutting blades do not come into contact with the ground or any other objects.

**Cold starting:** (When the engine is cold or it has been stopped for more than 5 minutes or when fuel is added to the engine.)

1. Push the I-O switch (1) to "I" position.
2. Repeat pushing the primer pump (2) gently (7 to 10 times) until the fuel comes into the primer pump.
3. Move the choke lever (3) to position "I".
4. Hold the hedge trimmer down firmly to avoid loss of control while cranking the engine. Failure to do so may cause serious injury and/or property damage due to falling or contact with the cutting blade.
5. Pull the starter handle slowly for 10 to 15 cm until you feel the resistance.
6. Pull the starter handle strongly with feeling the resistance and start the engine.
7. When the engine starts or pop-up and stop, return the choke lever (4) to "O".
8. Run the engine for approximately one minute at a moderate speed before accelerating to full throttle.

**Note:**

- If the starter handle is pulled repeatedly when the choke lever remains at "I" position, the engine will not start easily due to excessive fuel intake.
- In case of excessive fuel intake, remove the spark plug and pull the starter handle slowly to remove excess fuel. Also, dry the electrode section of the spark plug.

**Hot starting:** (Restarting immediately after the engine has stopped.) When restarting a hot engine, first try the above procedure: 1, 2, 4, 5, 6 with the choke lever (4) to "O". If the engine does not start, repeat above steps 1-8.

**Note:** Do not pull the starter rope to its full extension. Do not allow the starter grip to be retracted without control. Ensure that it is retracted slowly.

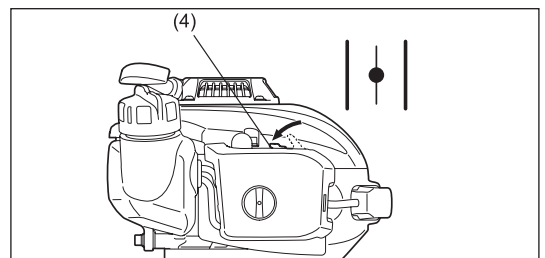
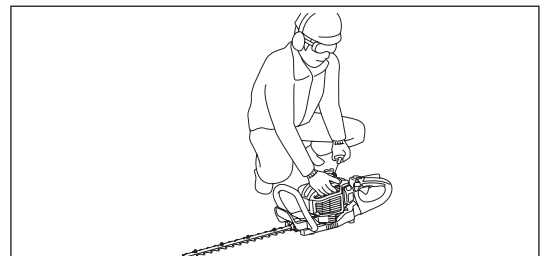
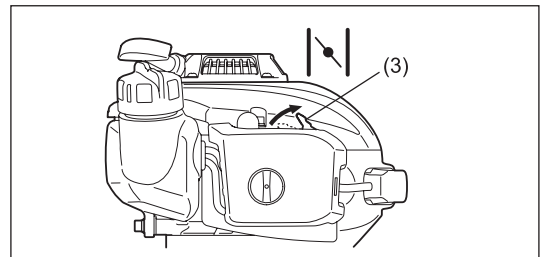
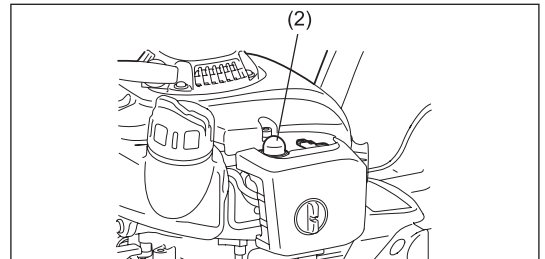
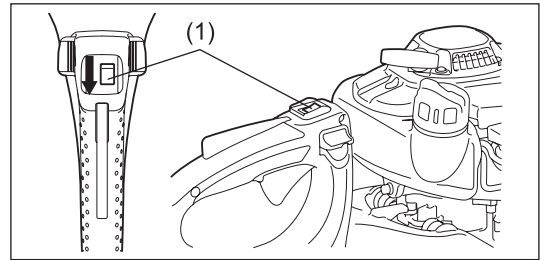

## STOPPING THE MACHINE

1. Release the throttle lever completely.
2. Push the I-O switch (1) to "O" position. The engine will slow down and stop.

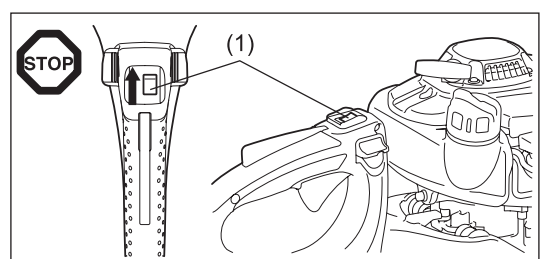

## OPERATION OF THE MACHINE

- Never operate the hedge trimmer with a loose grip.
- Never touch the cutting blades when starting the engine and during operation.
- Operate the hedge trimmer in such a manner as to avoid inhalation of the exhaust gases. Never run the engine in enclosed rooms (Risk of gas poisoning). Carbon monoxide is an odorless gas.
- All protective equipment such as a guard supplied with the machine must be used during operation.
- Never operate the engine if the muffler is faulty or missing.
- Use the hedge trimmer only in good light and visibility.
- During the winter season beware of slippery or wet areas, ice and snow. (Risk of slipping.) Always ensure a safe footing.
- Never stand on a ladder and run the hedge trimmer. Keep both feet on the ground.
- Never climb up the trees with the hedge trimmer to perform cutting operation.
- Never work on unstable surfaces.
- Remove sand, stone, nails, wire, etc. found within the working area. Foreign objects may damage the cutting blades.
- Prior to the cutting operation, cut away 8 mm or thicker branches with pruning shears.
- Before commencing cutting, the cutting blades must have reached full working speed.
- Always hold the hedge trimmer firmly with both hands on the handles.
- Use a firm grip with thumbs and fingers encircling the handles.
- When you release the throttle, it takes a few moments before the cutting blades stop.
- Do not operate the hedge trimmer with high idle speed. You cannot adjust the cutting speed with the throttle control if the idle speed is too high.
- During the cutting operation, hold the hedge trimmer so that the blades form a 15-30° angle with the cutting line.
- Pay special attention when cutting hedges close to or against wire fences.
- Do not touch hard objects such as wire fence, stone or ground with the cutter blades. It may cause blades to crack, chip or break.
- Should the cutting blades hit stones or other hard objects, immediately switch off the engine and inspect the cutting blades for damage. Replace damaged blades before re-commencing work.
- Take a rest periodically. Makita recommends to take a 10- to 20-minute rest every 50 minutes of use.
- Switch off the engine immediately in case of any engine problems.
- Operate the hedge trimmer with as little noise and contamination as possible. In particular check the correct setting of the carburetor and the fuel/oil ratio.
- Never attempt to remove jammed cut material when blades are running. Put unit down, turn it off, and remove necessary cuttings.

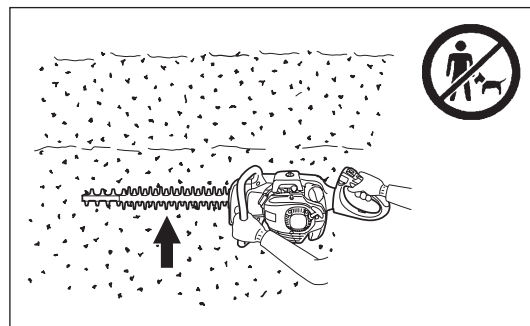
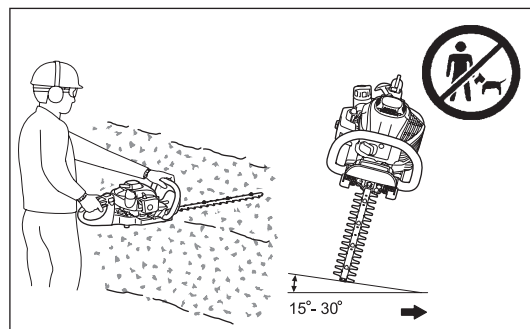

## ADJUSTING REAR HANDLE ANGLE

The rear handle can be turned down to 90° to the left or right side and set at every 45°.

To change the angle:

1. Press the release lever to release the lock.
2. Turn the handle to an angle of 0°, 45° or 90°.
3. Make sure that the release lever returns to the original position to engage the lock.

Do not pull the throttle lever while the lock is released.

Do not release the lock during operation.

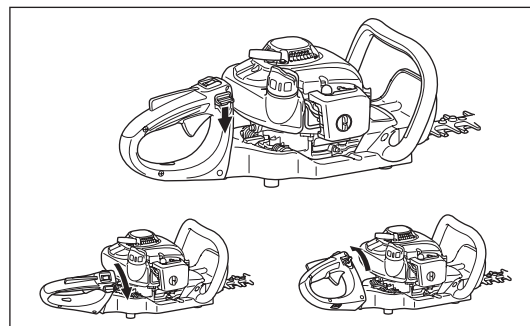

## MAINTENANCE INSTRUCTIONS

- Turn off the engine and remove the spark plug connector when cleaning/replacing/sharpening the cutting blades or carrying out any maintenance.
- Never straighten or weld a damaged cutting blade.
- Frequently inspect the cutting blades for damage with the engine switched off.
- Keep the cutting blades sharp.
- Clean the hedge trimmer and check that all screws and nuts are well tightened regularly.
- Never service the hedge trimmer in the vicinity of naked flames to avoid fires.
- Always wear leather gloves when handling or sharpening the blades, as they are sharp.

### Sharpening blade

If the edges are rounded and do not cut well any more, grind off only the shaded portions in the figure. Do not grind the contact surfaces (sliding surfaces) of the top and bottom edges.

- Before grinding, be sure to secure the blade firmly and switch off the engine and remove the spark plug cap.
- Wear gloves, protective glasses, etc.
- Do not remove too much material. It loses the hardened layer and causes the blades to get dull very quickly in use.

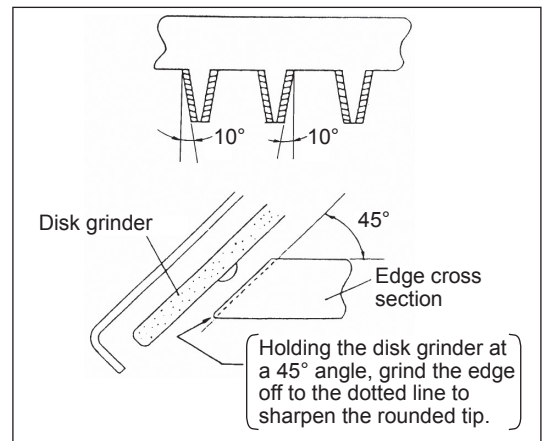

### Adjusting blade clearance

The upper/lower blades wear. If you cannot get a clean cut though the blades are sharp enough, adjust the clearance as follows.

1. Remove the blunt extension by loosening the screws.
2. Loosen the nut (1) with a box or open-ended wrench.
3. Tighten the truss bolt (2) with a hex wrench lightly till it stops and screw it back a quarter turn.
4. Tighten the nut (1), holding the truss bolt (2).
5. Apply light oil on the friction surface of the blades.
6. Start the engine, operate the throttle on and off for a minute.
7. Measure the time necessary for the blades to stop after releasing the throttle. If it is two seconds or longer, stop the engine and repeat the step 2 to 7.
8. Stop the engine and touch the blade surface. If they are not too hot to touch, you have made a proper adjustment. If they are too hot to touch, turn the truss bolt (2) back a little and repeat the step 6 to 8.
9. Attach the blunt extension by tightening the screws.

**NOTE:** Before making the adjustment, stop the engine and wait for the blades to stop. The blades have a slot around screw (2). In case you find dust in the end of any of the slots, clean it.

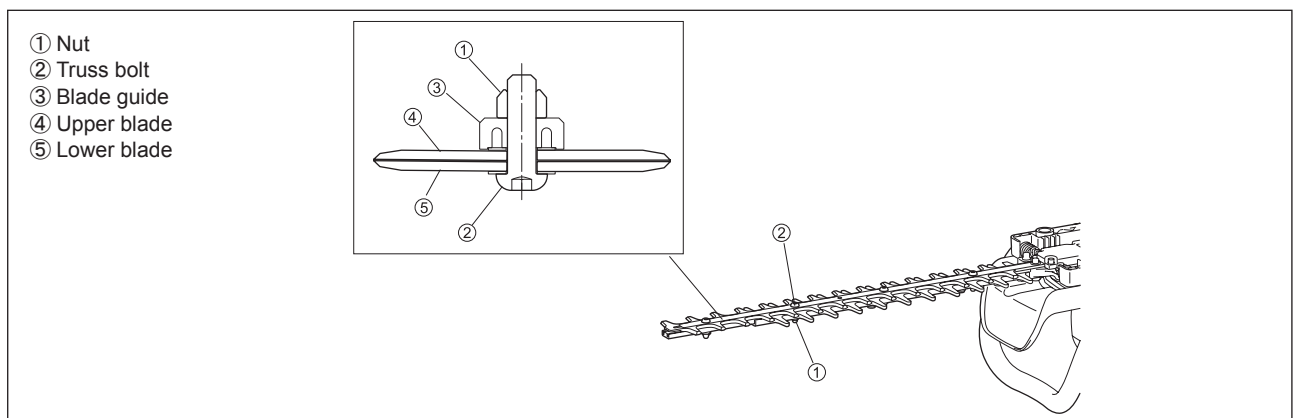

## Checking and adjusting the idling speed

The cutting blades should not run when the engine is at idle.

- Idle speed should be set to 3,000 min<sup>-1</sup> (rpm).
- If necessary, adjust the idle screw (the cutting blades must not run when the engine is on idle).
  - The cutting blades run while idling - turn the idle screw counterclockwise to decrease the idle speed.
  - The engine stops while idling - turn the idle screw clockwise to increase the idle speed.

If the cutting blades still continue to run at idle after the adjustment, consult your nearest authorized service agent.

- The clutch should engage at 3,750 min<sup>-1</sup> (rpm) or higher revolution.
- Check the functioning of the I-O switch, the lock-off lever and the throttle lever.

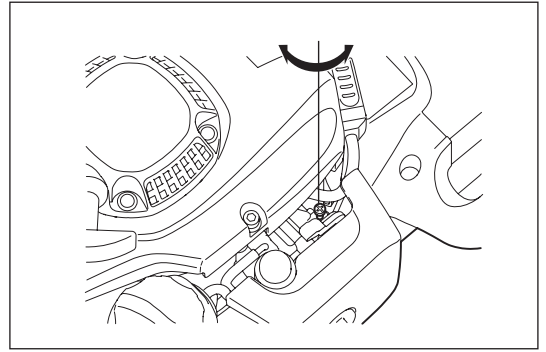

## Cleaning the air cleaner



**DANGER: Inflammables strictly prohibited**

Check and clean the air cleaner daily or every 10 operating hours.

- Turn the choke lever to the close side fully, and keep the carburetor free from dust or dirt.
- Loosen the fixing bolt.
- Pull the rear side of the air cleaner cover and move it forward to detach.
- If oil adheres to the element (sponge), squeeze it firmly.
- For heavy contamination:
  - 1) Remove the element (sponge), immerse it in warm water or in water-diluted neutral detergent, and dry it completely.
  - 2) Clean the element (felt) with gasoline, and dry it completely.
- Before attaching the elements, be sure to dry it completely. Insufficient drying of the elements may lead to difficult startup.
- Wipe out oil adhering around the air cleaner with waste cloth.
- Immediately after cleaning is finished, attach the cleaner cover and tighten it with fixing bolts. (In remounting, first place the upper claw.)

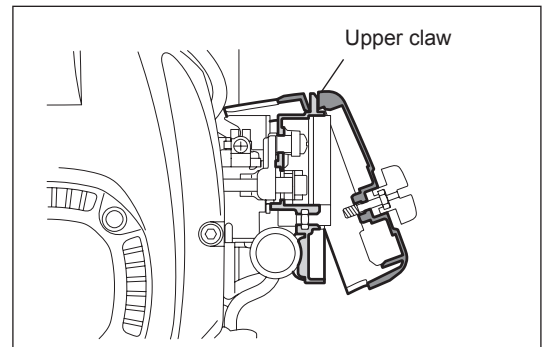
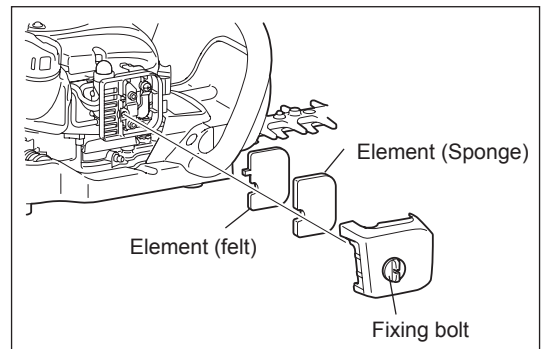

### Points in handling the air cleaner elements

- Clean the elements several times a day, if excessive dust adheres to it.
- If operation continues with the elements remaining not cleared of oil, oil in the air cleaner may fall outside, resulting in oil contamination.

## Checking the spark plug

Check and clean the spark plug daily or every 8 operating hours.

- Only use the supplied universal wrench to remove or install the spark plug.
- The gap between the two electrodes of the spark plug should be 0.7 to 0.8 mm. If the gap is too wide or too narrow, adjust it. If the spark plug is clogged with carbon or fouled, clean it thoroughly or replace it. Use an exact replacement.

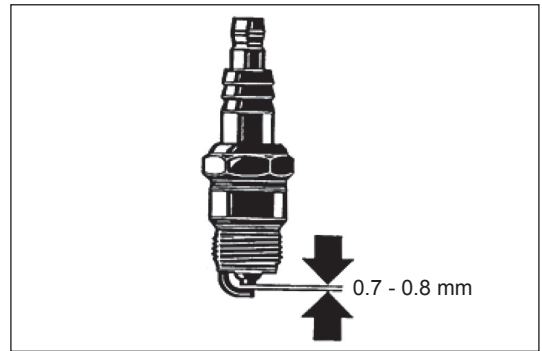

## Supplying grease and lubricant

- Supply grease through the grease nipple every 50 operating hours. (Shell Alvania No. 3 or equivalent)

**NOTE:** Be sure to observe the specified time and amount of grease supply. Otherwise an insufficient grease supply will cause a machine trouble.

## Cleaning the fuel filter (suction head in the fuel tank)

**WARNING: Inflammables strictly prohibited**

Check and clean the fuel filter monthly or every 50 operating hours.

- The felt filter (1) of the suction head is used to filter the fuel required by the carburetor.
- Visually check the felt filter regularly.
- To check the felt filter, open the tank cap, use a wire hook and pull out the suction head through the tank opening. Replace the felt filter if it has hardened, been contaminated or be clogged.
- Replace the felt filter at least quarterly to ensure an enough fuel supply to the carburetor. Otherwise an insufficient fuel supply will cause the engine start failure and limited maximum speed.

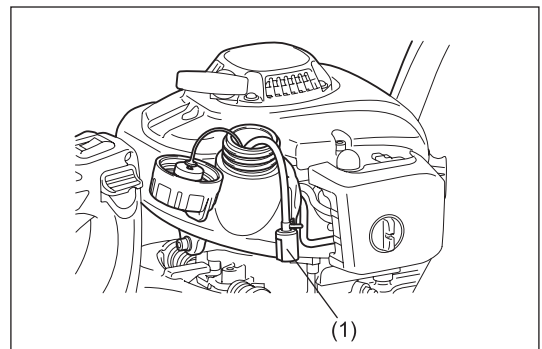
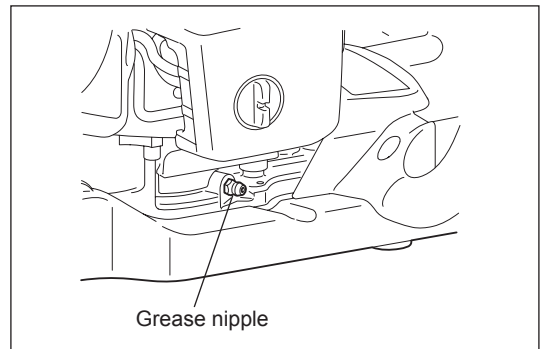

## Replacing the fuel pipe

**CAUTION: Inflammables strictly prohibited**

Check and clean the fuel pipe daily or every 10 operating hours.

Replace the fuel pipe every 200 operating hours or every year regardless of operating frequency. Otherwise fuel leakage may lead to fire.

If you find any leakage during inspection, replace the oil pipe immediately.

## Replacing the tank cap

- If there is any flaw or damage on the tank cap, replace it.
- The tank cap wears out in course of time. Replace it every two or three years.

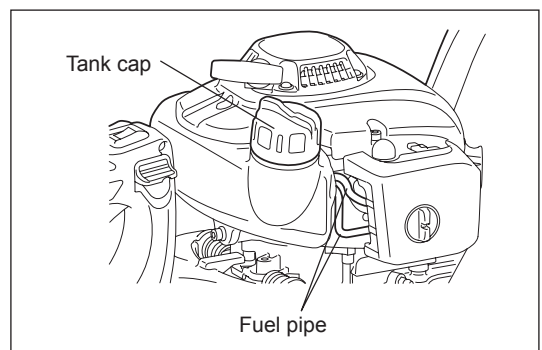

For any maintenance or adjustment not described in this manual, ask your local Makita authorized service center.

## Daily checkup and maintenance

To ensure a long service life and to avoid any damage to the equipment, the following servicing operations should be performed at regular intervals.

- Before use;
  - Check the machine for loose screws or missing parts. Pay particular attention to the tightness of the cutter blade screws.
  - Check for clogging of the cooling air passage and the cylinder fins. Clean them if necessary.
  - Clean and check the fuel tank for fuel leakage or foreign object in the tank.
- After use;
  - Clean the hedge trimmer externally and inspect for damage.
  - Clean the air filter. When working under extremely dusty conditions, clean the filter several times a day.
  - Check the blades for damage and make sure they are firmly mounted.

## STORAGE

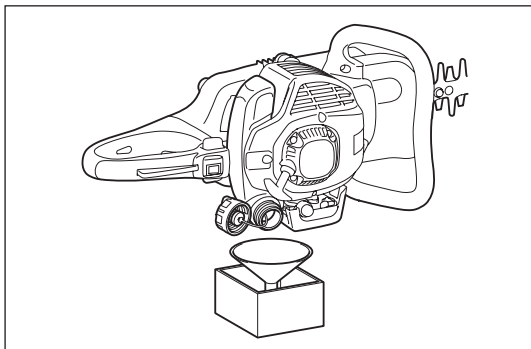

- When keeping the machine in storage for a long time, drain fuel from the fuel tank and carburetor, as follows: Drain all fuel from the fuel tank.
- Remove the spark plug and add a few drops of oil into the spark plug hole. Then, pull the starter gently to confirm that oil film covers inside of the engine and tighten the spark plug.
- Clear dirt or dust from the cutter blade and outside of the engine, wipe them with a oil-immersed cloth and keep the machine at a place as dry as possible.

## MAINTENANCE SCHEDULE

<b>After each refuelling</b>	Throttle lever I-O switch	Check the function Check the function
<b>Before each use</b>	Engine assembly, screws and nuts Air filter Cooling air duct Cutting tool Idling speed Fuel tank	Visually check for damage and tightness Check for general condition and security Clean Clean Check for damage and sharpness Inspection (cutting tool must not move) Check and clean
<b>Every 50 hours</b>	Gear case	Supply grease
<b>Weekly</b>	Spark plug	Check and replace if necessary
<b>Yearly</b>	Fuel pipe	Replace
<b>Biyearly</b>	Tank cap	Replace
<b>Before long term storage</b>	Fuel tank Carburetor Suction head	Empty and clean Operate until the engine runs out of fuel Replace

## FAULT LOCATION

Fault	System	Observation	Cause
Engine not starting or under difficulties	Ignition system	Ignition spark is present	Faulty fuel supply or compression system, mechanical defect
		No ignition spark	I-O switch operated, wiring fault or short circuit, spark plug or connector defective, ignition module faulty
	Fuel supply	Fuel tank filled	Incorrect choke position, carburetor defective, suction head (gas line filter) dirty, fuel supply line bent or interrupted
	Compression	Inside of engine	Cylinder bottom gasket defective, crankshaft seals damaged, cylinder or piston rings defective
		Outside of engine	Improper sealing of spark plug
Mechanical fault		Starter not engaging	Broken starter spring, broken parts inside of the engine
		Tank filled Ignition spark existing	Carburetor contaminated, have it cleaned
Warm start problems			
Engine starts but dies immediately	Fuel supply	Tank filled	Incorrect idling adjustment, suction head or carburetor contaminated
			Fuel tank vent defective, fuel supply line interrupted, cable or I-O switch faulty
Insufficient performance	Several systems may simultaneously be affected	Engine idling	Air filter contaminated, carburetor contaminated, muffler clogged, exhaust duct in the cylinder clogged

Makita Corporation

[www.makita.com](http://www.makita.com)

885103-9

ALA



## Free Manuals Download Website

<http://myh66.com>

<http://usermanuals.us>

<http://www.somanuals.com>

<http://www.4manuals.cc>

<http://www.manual-lib.com>

<http://www.404manual.com>

<http://www.luxmanual.com>

<http://aubethermostatmanual.com>

Golf course search by state

<http://golfingnear.com>

Email search by domain

<http://emailbydomain.com>

Auto manuals search

<http://auto.somanuals.com>

TV manuals search

<http://tv.somanuals.com>