

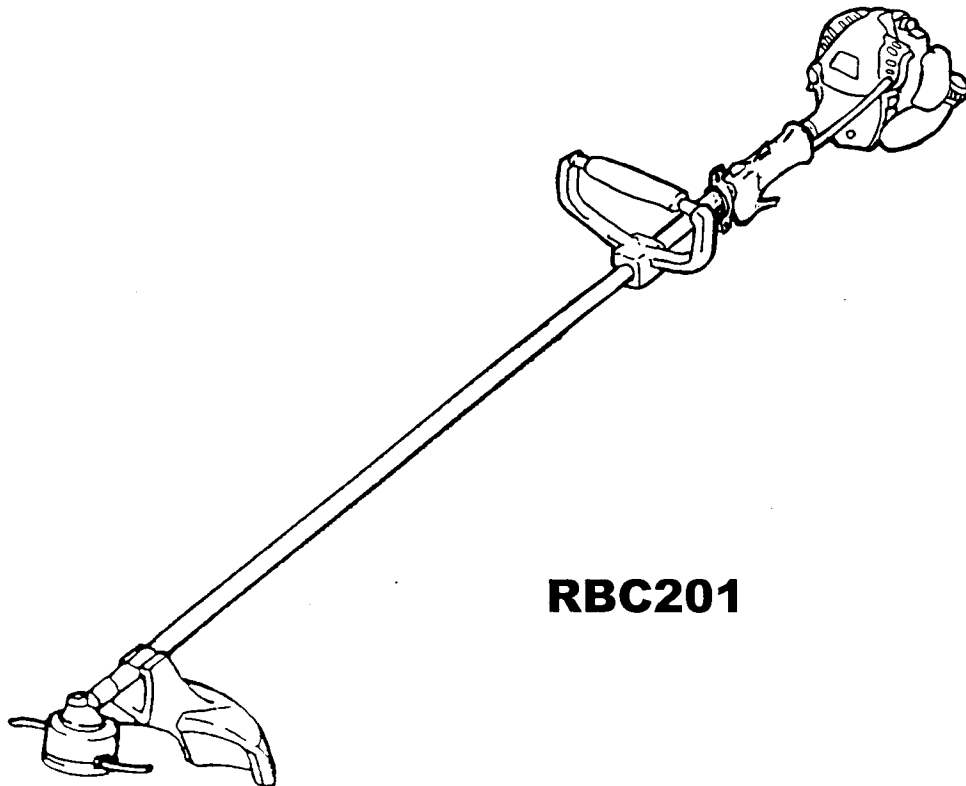

String Trimmer

RBC201

INSTRUCTION MANUAL



RBC201

Important:

Read this instruction manual carefully before putting the String Trimmer into operation and strictly observe the safety regulations!
Preserve instruction manual carefully!

Thank you very much for purchasing the MAKITA String Trimmer. We are pleased to recommend to you the MAKITA String Trimmer which is the result of a long development programme and many years of knowledge and experience.

Please read this booklet which refers in detail to the various points that will demonstrate its outstanding performance. This will assist you to obtain the best possible result from your MAKITA String Trimmer.



Table of Contents	Page
Symbols	2
Safety instructions	3
Technical data	6
Designation of parts	7
Assembly of engine and shaft.....	8
Mounting of handle.....	8
Mounting of protector	9
Mounting of nylon cutting head.....	9
Fuels/Refuelling	10
Correct handling of machine.....	11
Putting into operation	11
Idle adjustment.....	12
Nylon cutting head.....	12
Servicing instructions	14
Storage	16
California emission control warranty statement.....	17
Federal emission component defect warranty.....	21

SYMBOLS

You will note the following symbols when reading the instructions manual.

	Read instruction Manual		Do not use metal blades
	Take Particular Care and Attention		Top permissible tool speed
	Forbidden		Fuel and oil mixture
	Keep distance		Engine-Manual start
	Flying object hazard		Emergency stop
	No smoking		First Aid
	No naked flame		Recycling
	Protective gloves must be worn		ON/START
	Keep the area of operation clear of all persons and pets		OFF/STOP
	Wear eye and ear protection (for grass trimmer)		EC-mark

SAFETY INSTRUCTIONS

General Instructions

- To ensure correct operation, user has to read this instruction manual to make himself familiar with the handling of the string trimmer. Users insufficiently informed will risk danger to themselves as well as others due to improper handling.
- It is recommended only to lend the string trimmer to people who have proven to be experienced with string trimmers. Always hand over the instruction manual.
- First users should ask the dealer for basic instructions to familiarize oneself with the handling of an engine powered trimmer.
- Children and young persons aged under 18 years must not be allowed to operate the string trimmer. Persons over the age of 16 years may however use the device for the purpose of being trained only whilst under supervision of a qualified trainer.
- Use string trimmers with the utmost care and attention.
- Operate the string trimmer only if you are in good physical condition. Perform all work calmly and carefully. The user has to accept liability for others.
- Never use the string trimmer after consumption of alcohol or drugs, or if feeling tired or ill.

Intended use of the machine

- The String Trimmer is only intended for cutter grass, weeds, Bushes, undergrowth it should not be used for any other purpose such as Edging or hedge cutting as this may cause injury.

Personal protective equipment

- The clothing worn should be functional and appropriate, i.e. it should be tight-fitting but not cause hindrance. Do not wear either jewelry or clothing which could become entangled with bushes or shrubs.
- In order to avoid either head-, eye-, hand- or foot injuries as well as to protect your hearing the following protective equipment and protective clothing must be used during operation of the string trimmer.
- Always wear a helmet where there is a risk of falling objects. The protective helmet (1) is to be checked at regular intervals for damage and is to be replaced at the latest after 5 years. Use only approved protective helmets.
- The visor (2) of the helmet (or alternatively goggles) protects the face from flying debris and stones. During operation of the string trimmer always wear goggles, or a visor to prevent eye injuries.
- Wear adequate noise protection equipment to avoid hearing impairment (ear muffs (3), ear plugs etc.).
- The work overalls (4) protect against flying stones and debris. We strongly recommend that the user wears work overalls.
- Special gloves (5) made of thick leather are part of the prescribed equipment and must always be worn during operation of the string trimmer.
- When using the string trimmer, always wear sturdy shoes (6) with a non-slip sole. This protects against injuries and ensures a good footing.

Starting up the string trimmer

- Please make sure that there are no children or other people within a working range of 15 meters (49ft), also pay attention to any animals in the working vicinity.
- Before use always check that the string trimmer is safe for operation: Check the security of the nylon cutting head, the control lever for easy action.
- Rotation of the nylon cutting head during idling speed is not allowed. Check with your dealer for adjustment if in doubt. Check for clean and dry handles and test the function of the start/stop switch.

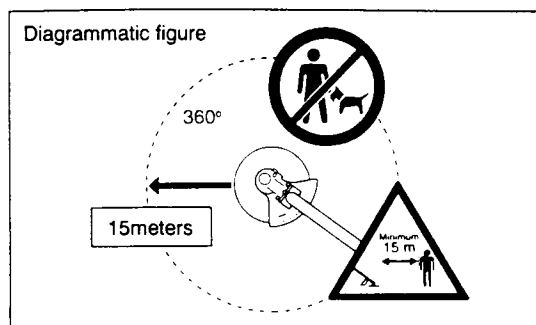
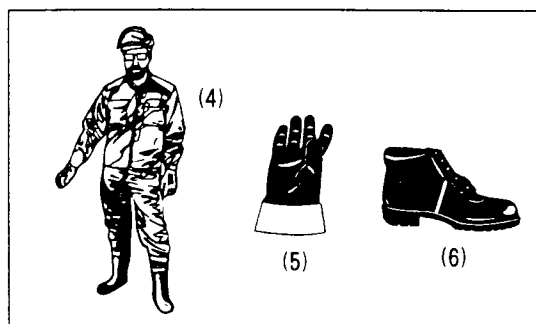
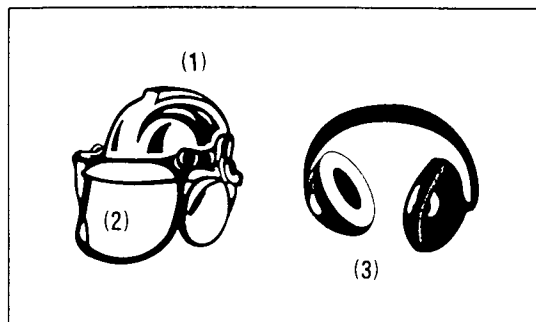
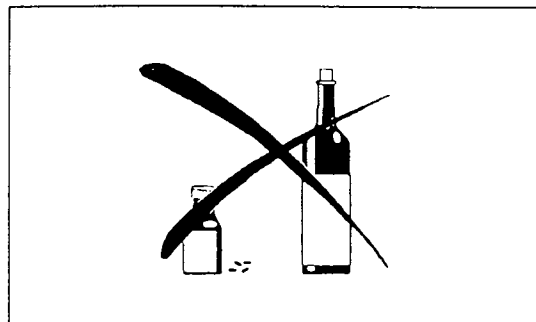
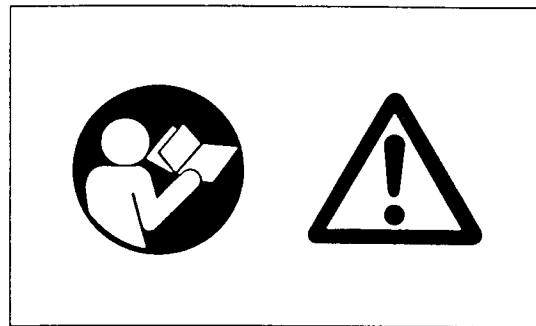

Start the string trimmer only in accordance with the instructions.
Do not use any other methods for starting the engine!

- Use the string trimmer and the tools only for such applications as specified.
- Only start the string trimmer engine, after the entire assembly is done. Operation of the device is only permitted after all the appropriate accessories are attached!
- Before starting make sure that the nylon cutting head has no contact with hard objects such as branches, stones etc. as the cutting tool will revolve when starting.
- The engine is to be switched off immediately in case of any engine problems.
- Should the nylon cutting head hit stones or other hard objects, immediately switch off the engine and inspect the nylon cutting head.
- Inspect the nylon cutting head at short regular intervals for damage (detection of hairline cracks by means of tapping-noise test).
- Operate the string trimmer only with the shoulder strap attached which is to be suitably adjusted before putting the string trimmer into operation. It is essential to adjust the shoulder strap according to the use's size to prevent fatigue occurring during use.
- During operation always hold the string trimmer with both hands. Always ensure a safe footing.
- Operate the string trimmer in such a manner as to avoid inhalation of the exhaust gases. Never run the engine in enclosed rooms (risk of gas poisoning). Carbon monoxide is an odorless gas.
- Switch off the engine when resting and when leaving the string trimmer unattended, and place it in a safe location to prevent danger to others or damage to the machine.
- Never put the hot string trimmer onto dry grass or onto any combustible materials.
- The nylon cutting head has to be equipped with it's appropriate guard. Never run the trimmer without this guard!
- All protective installations and guards supplied with the machine must be used during operation.
- Never operate the engine with faulty exhaust muffler.
- Shut off the engine during transport.
- During transport over long distances the tool protection included with the equipment must always be used.
- Ensure safe position of the string trimmer during car transportation to avoid fuel leakage.
- When dispatching the string trimmer, ensure that the fuel tank is completely empty.
- When unloading the String Trimmer from the truck, never drop the Engine to the ground or this may severely damage the fuel tank.
- Except in case of emergency, never drop or cast the String Trimmer to the ground or this may severely damage the String Trimmer
- Remember to lift the entire equipment from the ground when moving the equipment. Dragging the fuel tank is highly dangerous and will cause damage and leakage of fuel, possibly causing fire.

Refuelling

- Shut off the engine during refuelling, keep away from naked flames and do not smoke.
- Avoid skin contact with mineral oil products. Do not inhale fuel vapor. Always wear protective gloves during refuelling. Change and clean protective clothing at regular intervals.
- Take care not to spill either fuel or oil in order to prevent soil contamination (environmental protection). Clean the string trimmer immediately after fuel has been spilt.
- Avoid any fuel contact with your clothing. Change your clothing instantly if fuel has been spilt on it (to prevent clothing catching fire).
- Inspect the fuel cap at regular intervals making sure that it can be securely fastened and does not leak.
- Carefully tighten the fuel tank cap. Change location to start the engine (at least 3 meters away from the place of refuelling).
- Never refuel in closed rooms. Fuel vapors accumulate at ground level (risk of explosions).
- Only transport and store fuel in licensed containers. Make sure the fuel stored is not accessible to children.

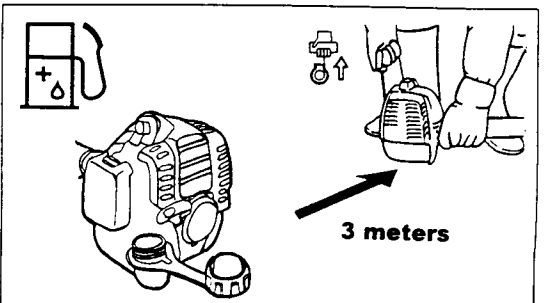
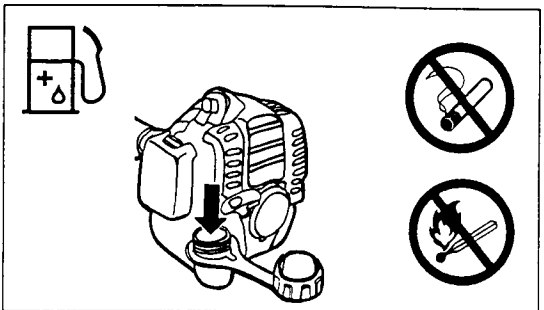
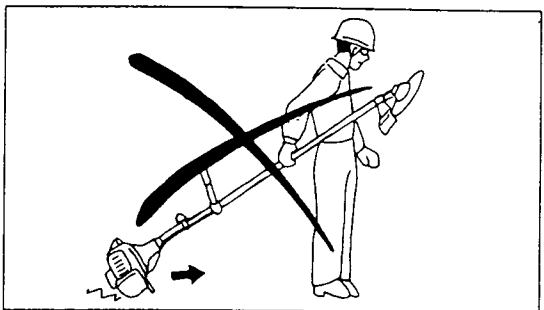
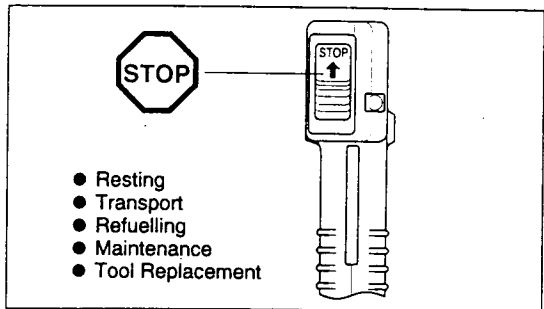
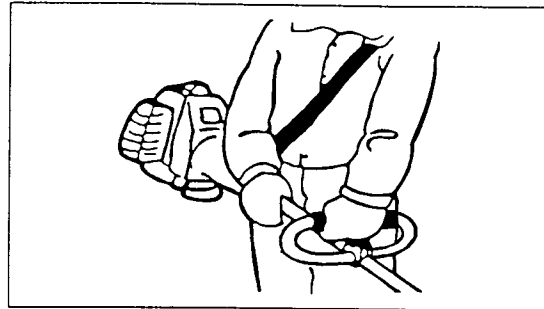
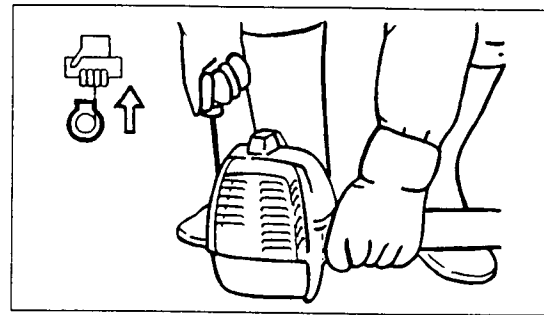

Method of operation

- Only use the string trimmer in good light and visibility. During the winter season beware of slippery or wet areas, ice and snow (risk of slipping). Always ensure a safe footing.
- Never cut above waist height.
- Never stand on a ladder and run the string trimmer.
- Never climb up into trees to perform cutting operation with the string trimmer.
- Never work on unstable surfaces.
- Remove sand, stones, nails etc. found within the working range. Foreign particles may damage the nylon cutting head and can cause dangerous kick-backs.
- Before commencing cutting, the nylon cutting head must have reached full working speed.



Cutting Tools

Employ only the correct nylon cutting head for the job in hand.

For cutting thick materials, such as weed, high grass, bushes, shrubs, underwood, thicket etc. (max. 2 cm dia. thickness). Perform this cutting work by swinging the string trimmer evenly in half-circles from right to left (similar to using a scythe).



Maintenance instructions

- The condition of the trimmer also of the shoulder strap must be checked before commencing work.
- Turn off the engine and remove spark plug connector when replacing, and also when cleaning the nylon cutting head.
- Operate the string trimmer with as little noise and contamination as possible. In particular check the correct setting of the carburetor.
- Clean the string trimmer at regular intervals and check that all screws and nuts are well tightened.
- Never service or store the string trimmer in the vicinity of naked flames.
- Always store the string trimmer in locked rooms and with an emptied fuel tank.

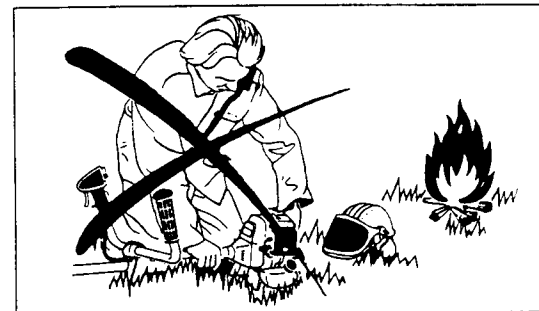

Observe the relevant accident prevention instructions issued by the relevant trade associations and by the insurance companies.
Do not perform any modifications on the string trimmer as this will endanger your safety.

The performance of maintenance or repair work by the user is limited to those activities as described in the instruction manual. All other work is to be done by an Authorized Service Agent. Use only genuine spare parts and accessories released and supplied by MAKITA.
Use of non-approved accessories and tools means increased risk of accidents. MAKITA will not accept any liability for accidents or damage caused by the use of non-approved nylon cutting heads and fixing devices of nylon cutting heads, or accessories.

First Aid

In case of accident make sure that a first-aid box is available in the vicinity of the cutting operations. Immediately replace any item taken from the first aid box.

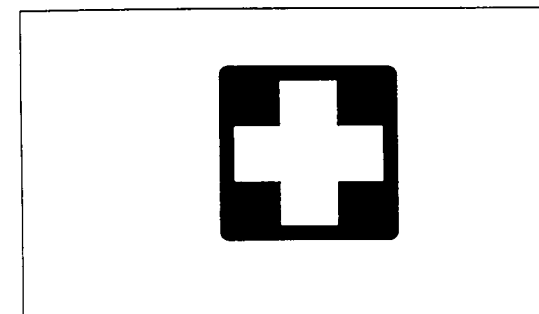

When asking for help, please give the following information:

- Place of accident
- What happened
- Number of injured persons
- Kind of injuries
- Your name

TECHNICAL DATA

Model		RBC201
Dimensions : length x width x height (without nylon cutting head)	mm	1735 x 235 x 220 (68" x 9.3" x 8.7")
Mass (without plastic guard and nylon cutting head)	kg	3.7 (8.2 lb)
Volume (fuel tank)	cm ³	400
Engine displacement	cm ³	20.0
Maximum engine performance	kw	0.57/7000 1/min
Engine speed at recommended max. spindle speed	1/min	8800
Maximum spindle speed (corresponding)	1/min	6000
Fuel consumption	kg/h	—
Specific fuel consumption	g/kwh	—
Idling speed	1/min	3000
Clutch engagement speed	1/min	4000
Carburetor (Diaphragm - carburetor)	type	WALBRO WYL
Ignition system	type	Solid state ignition
Spark plug	type	NGK BM7A
Electrode gap	mm	0.6 ~ 0.7
Fuel		Mixed gas (gasoline : two stroke oil = 50 : 1)
Gear ratio		14/18

1) The data takes equally into account the idling and reving or wide open throttle speed operating modes.

*** WARNING: MODEL RBC201 must not be used with a metal blade.**

DESIGNATION OF PARTS

RBC201 String Trimmer

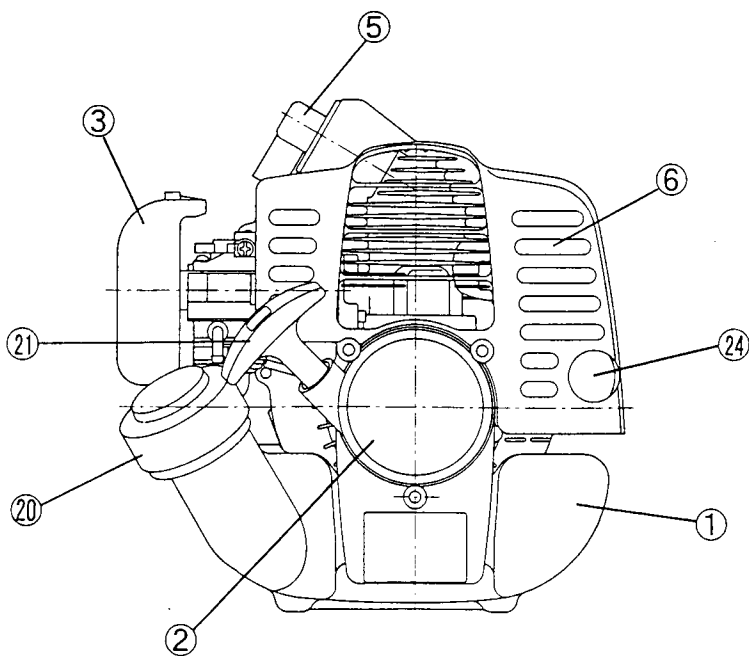
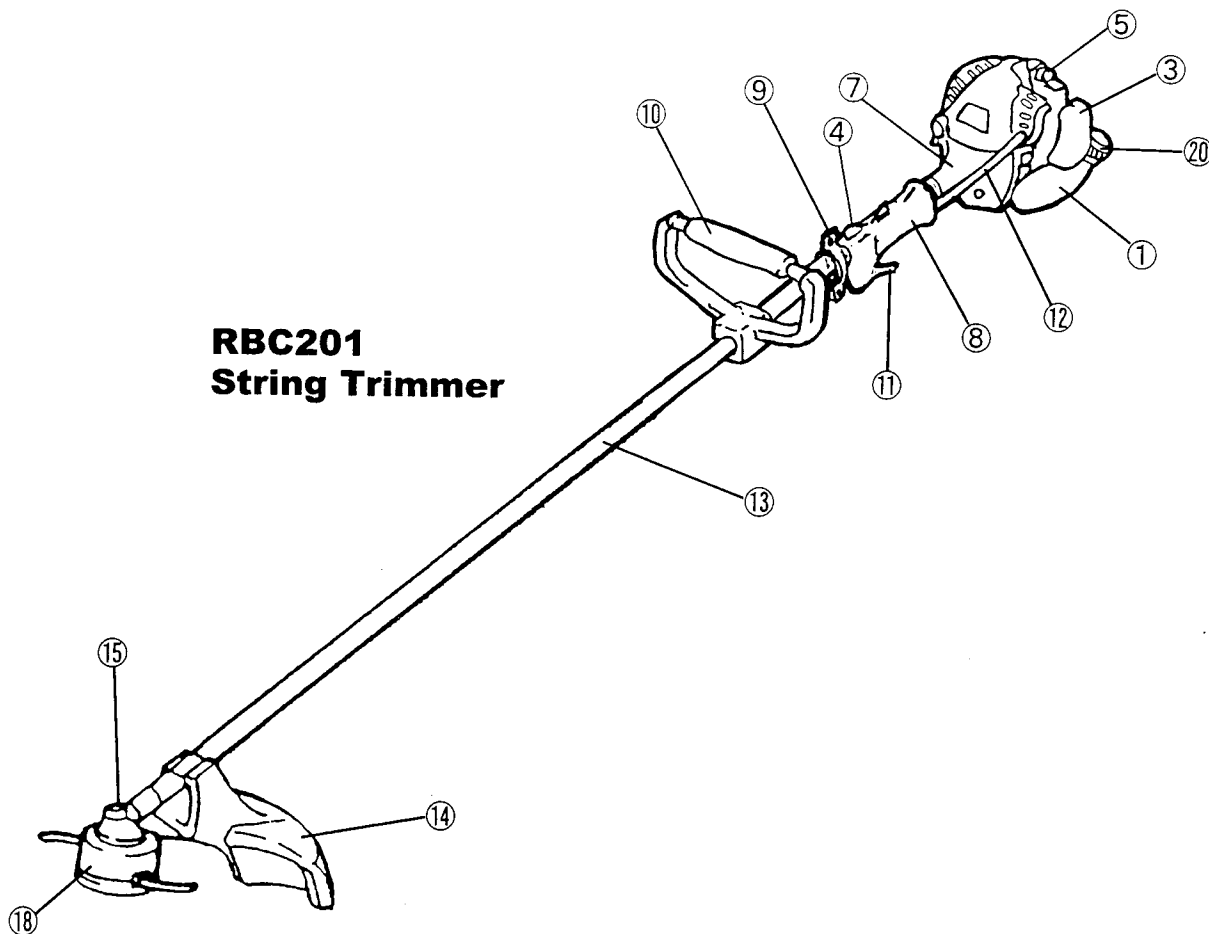

GB	DESIGNATION OF PARTS
1	Fuel Tank
2	Rewind Starter
3	Air Cleaner cover
4	I-O Switch (on/off)
5	Spark Plug
6	Exhaust Muffler
7	Clutch Case
8	Rear Grip
9	Hanger
10	Handle
11	Control Lever
12	Control Cable
13	Shaft
14	Protector
15	Gear Case/Head Case
18	Nylon Cutting Head
20	Fuel Filler Cap
21	Starter Knob
24	Exhaust Pipe

ASSEMBLY OF ENGINE AND SHAFT

CAUTION: Before doing any work on the Grass Trimmer, always switch off the engine and pull the spark plug connector off the spark plug.
Always wear protective gloves!

CAUTION: Start the Grass Trimmer only after having assembled it completely.

- Insert the drive shaft into the holder case (Fig).

Note: Always insert the drive shaft into the Clutch case fully (approx. 58 mm).
If the inner shaft resists full insertion of the drive shaft, try to insert it again after slightly rotating the drive shaft or the support washer on the gear case to match the inner shaft to the hole inside the holder case.

- After making sure that the drive shaft is installed fully and properly, tighten the tapping screw and socket head bolt M5 x 18 to secure the drive shaft.

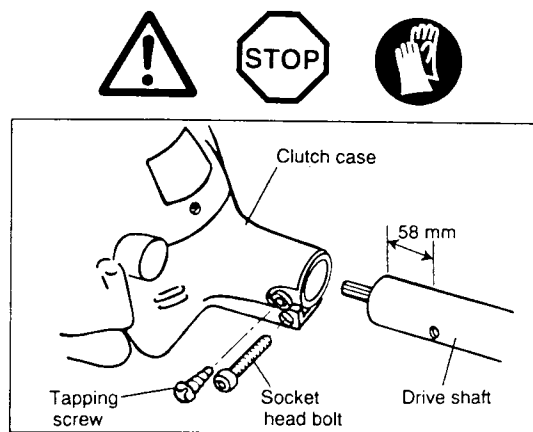

Remove the air cleaner cover from the carburetor.

- Inset control cable (1) through cylinder cover (2) and fit nipple of control cable into swivel (3) of carburetor.
- Re-fit air cleaner cover.

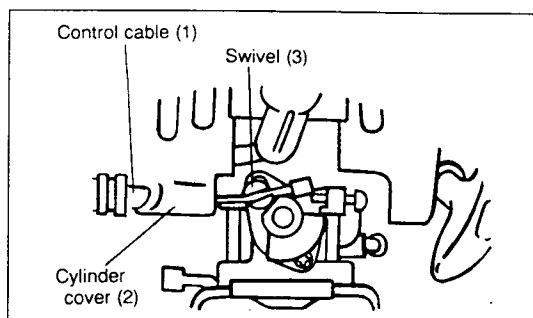

Connect the switch cords to the two cords from the engine by inserting one into the other.

- Fix the cord connector by clamp.

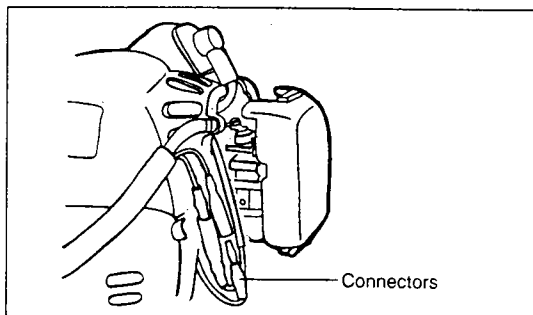

MOUNTING OF HANDLE

CAUTION: Before doing any work on the string trimmer, always switch off the engine and pull the spark plug connector off the spark plug.
Always wear protective gloves!

CAUTION: Start the string trimmer only after having assembled it completely.

- After the loop handle (8) is in place, tighten the four bolts (9). Be sure the bolts are tight, but do not over tighten.

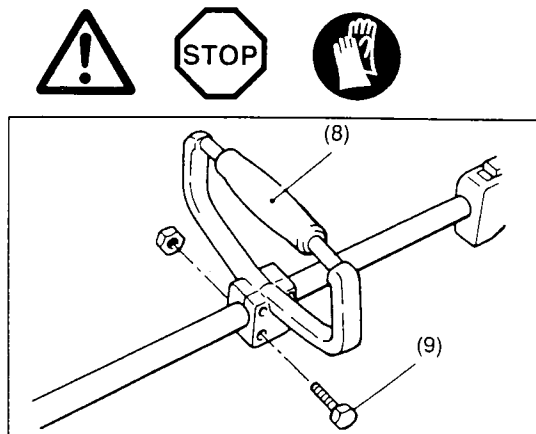

MOUNTING OF PROTECTOR

To meet the applicable safety provisions, only the tool/protector combinations as indicated in the table must be used.

Be sure to use genuine MAKITA nylon cutting head.

- If the nylon cutting head hits against a stone during operation, stop the engine and check the nylon cutting head immediately.

CAUTION: The appropriate protector must always be installed, for your own safety and in order to comply with accident-prevention regulations. Operation of the equipment without the guard being in place is not permitted.

- Install the clamp (3) on the shaft so that the projection of the clamp (3) is inserted into the opening between the gear case (1) and the shaft. Secure the protector (4) with the installation bolts M6 x 30 (2) and screw M5 x 8 (5).

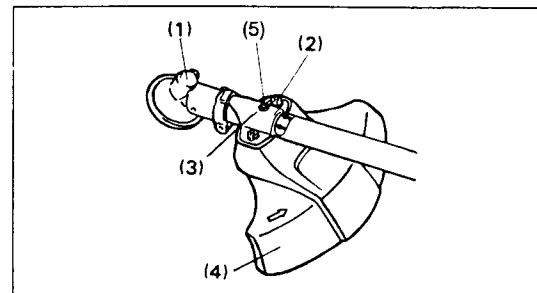
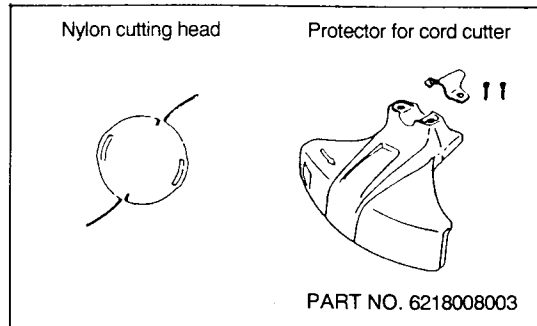

MOUNTING OF NYLON CUTTER HEAD

Turn the machine upside down, and you can replace the nylon cutting head.

- Insert the hex wrench through the hole in the gear case and rotate the receiver washer (3) until it is locked with the hex wrench.
- Loosen the nut (1) (left-hand thread) with the socket wrench and remove the nut (1), and clamp washer (2).

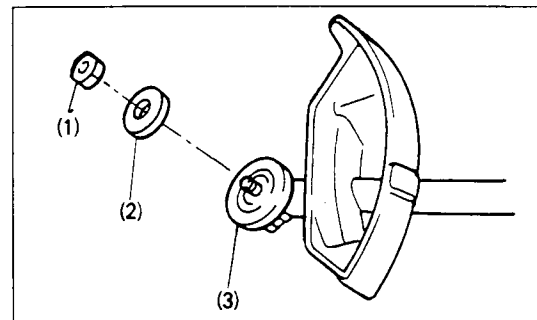

NOTE: The clamp washer (2), and nut (1) are not necessary for mounting the nylon cutting head. The nylon head should go on top of the receiver washer (3).

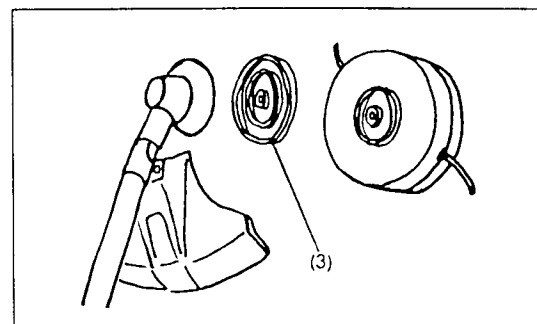

- Screw the nylon cutting head onto the shaft.

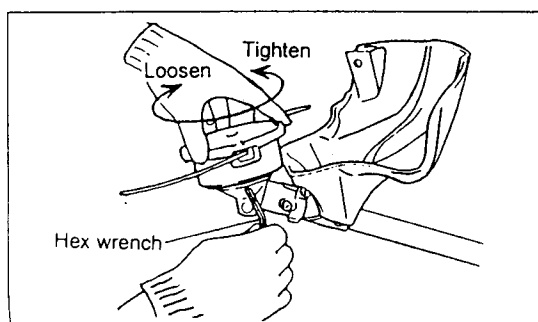

Make sure that the blade is the left way up.

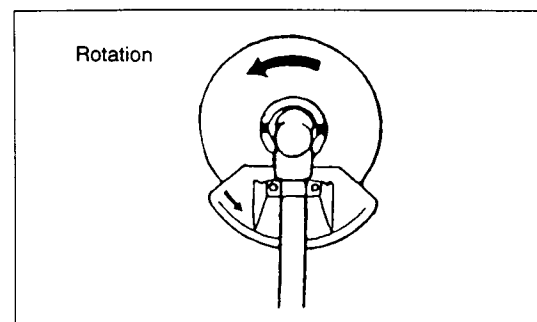

FUELS/REFUELING

Handling fuel

Utmost care is required when handling fuel. Fuel may contain substances similar to solvents. Refuel either in a well ventilated room or outdoors. Do not inhale fuel vapors, avoid any contact of fuel or oil with your skin. Mineral oil products degrease your skin. If your skin comes in contact with these substances repeatedly and for an extended period of time, it will desiccate. Various skin diseases may result. In addition, allergic reactions are known to occur. Eyes can be irritated by contact with oil. If oil comes into your eyes, immediately wash them with clear water. If your eyes are still irritated, see a doctor immediately!

Fuel and oil mixture

Inspect the fuel tank and fill with clean, fresh fuel of the proper mixture to assume the longer life of the tool.

Use the following mixed gas.

Gasoline : Makita genuine two-stroke engine oil = 50 : 1 or

Gasoline : Other Maker's Two-stroke oil = 25:1



Observe the Safety Instructions on page 3!

FOR CALIFORNIA REGULATION:

THIS EQUIPMENT IS CERTIFIED TO OPERATE ON GASOLINE + TWO STROKE OIL

When mixing gasoline with two-stroke engine oil, use only unleaded gasoline which contains no ethanol or methanol (type of alcohol).

This will help to avoid possible damage to engine fuel lines and other engine parts.

Do not mix gasoline and oil directly in the fuel tank.

IMPORTANT: Failure to follow proper fuel mix instructions may cause damage to the engine.

CAUTION: 1. When preparing fuel mixture, mix only the amount needed for the job you are to do.

Do not use fuel mixture that has been stored longer than two months.

Fuel mixture stored longer than two months will cause hard starting and poor performance.

If fuel mixture has stored longer than this time, it should be removed and filled with a fresh mixture.

2. Never fill the fuel to the very top.
3. Never add the fuel to the tank in a closed unventilated area.
4. Do not add fuel to this unit close to an open fire or sparks.
5. Be sure to wipe off spilled fuel before attempting to start the engine.
6. Do not attempt to refuel a hot engine.

Check points before operation

1. Check for loose bolts, nuts and fittings.
2. Check the air cleaner for dirt. Clean the air filter of all dirt, etc. before operation
3. Check to be sure that protector is securely in place.

Refuelling

The engine must be switched off!

- Thoroughly clean the area around the fuel filler cap (2), to prevent dirt from getting into the fuel tank (1).
- Unscrew the fuel filler cap (2) and fill the tank with fuel.
- Tightly screw on the fuel filler cap (2).
- Clean screw fuel filler cap (2) and tank after refueling!

Storage of Fuel

Fuel cannot be stored for an unlimited period of time.

Purchase only the quantity required for a 4 week operating period. Only use approved fuel storage containers.

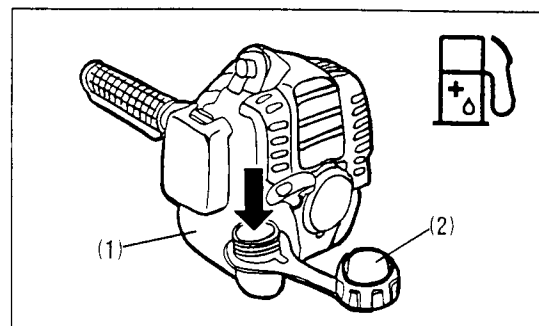
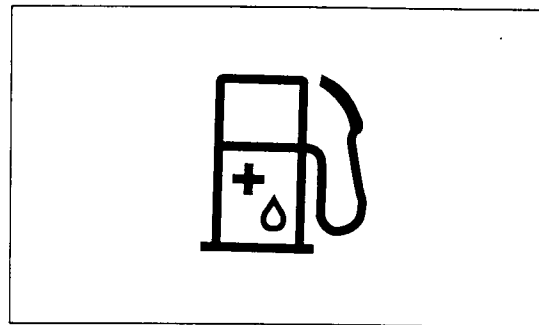

CORRECT HANDLING OF MACHINE

Attachment of shoulder strap

- Adjust the strap length so that the cutter blade will be kept parallel with the ground.

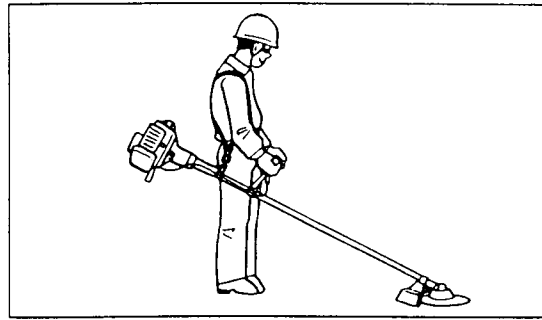

Detachment

- In an emergency, push the notches (1) at both sides, and you can detach the machine from you.
Be extremely careful to maintain control of the machine at this time. Do not allow the machine to be deflected toward you or anyone in the work vicinity.

WARNING: Failure to maintain complete control of the machine at all could result in serious bodily injury or DEATH.

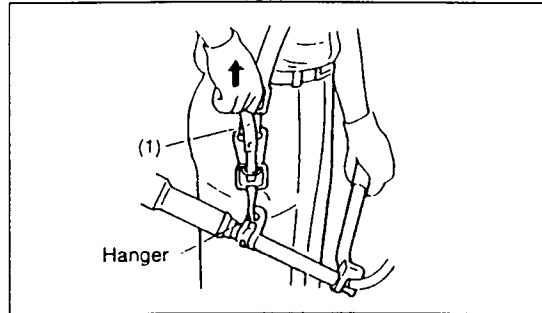

PUTTING INTO OPERATION

Observe the applicable accident prevention regulations!



Starting

Move at least 3m away from the place of refuelling. Place the string trimmer on a clean piece of ground taking care that the nylon cutting head does not come into contact with the ground or any other objects.

Cold start

For machine with Loop Handle

- Push the I-O switch (1) in the direction shown by the arrow.
- Grasp the handle (hand pressure activates the safety lock-off lever (5)).
- Press the throttle lever (6) and hold it down.
- Press the lock button (4) and release the control lever, and then release the lock button (the lock button holds the throttle lever in the start-up position).

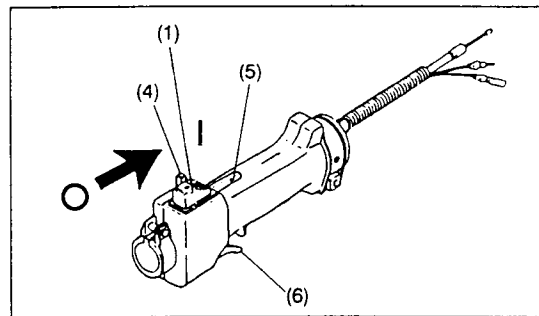

- First place the machine on the ground.
- Give a gentle push on the primer pump (1) repeatedly (7-10 times) until fuel comes into the primer pump.
- Move the choke lever (2) to the down position (|↓|)

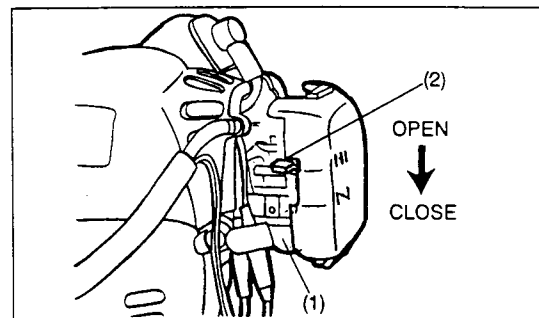

- Firmly hold the clutch case by your left hand, as illustrated.
- Slowly pull the starter grip until resistance is felt and continue with a smart pull.
- Do not pull out the starter rope to its full extent and do not allow the starter handle to be retracted without control, but ensure that it is retracted slowly.
- Repeat the starting operation until initial ignitions are heard.
- Depress the choke lever (|↓|) and pull the starter rope again until the engine starts.
- As soon as the engine starts, immediately tap and release the throttle, thus releasing the half-throttle lock so that the engine can run in idle.
- Run the engine for approximately one minute at a moderate speed before applying full throttle.

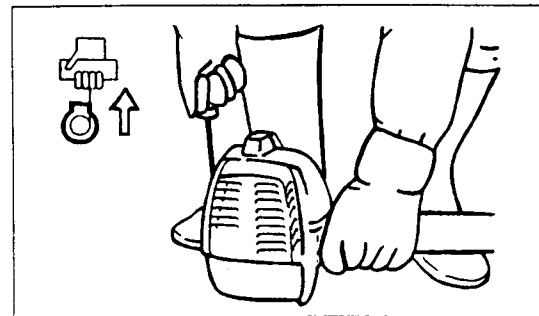

Note: – If the starter knob is pulled repeatedly when the choke lever remains at “ |←| ” position, the engine will not start easily due to excessive fuel intake.

- In case of excessive fuel intake, remove the spark plug and pull the starter knob slowly to remove excess fuel. Also, dry the electrode section of the spark plug.

Caution during operation:

If the control lever is opened fully in a no-load operation, the engine rotation is increased to 10,000 rpm or more. Never operate the engine at a higher speed than required and at an approximate speed of 6,000 - 8,000 rpm.

Starting the warm engine

- As described above, except without moving the choke lever (choke lever remains in the down position “ |↓| ”).
- Give a gentle push on the primer pump (1) repeatedly (7-10 times) until fuel comes into primer pump.

Stopping

- Release the control lever (6) fully, and when the engine rpm has lowered, push the I-O switch (1) to “O” position the engine will now stop.
- Be aware that the cutting head may not stop immediately and allow it to slow down fully.

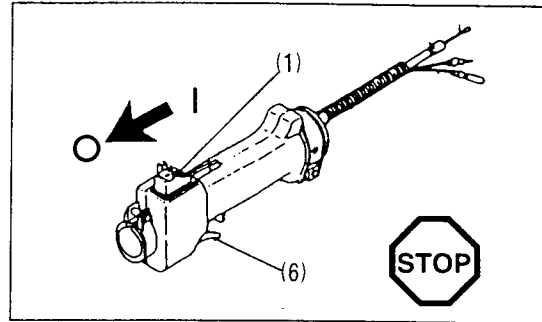

IDLE ADJUSTMENT

The nylon cutting head should not run when the control lever is fully released. If necessary, adjust the idle rpm using the idle adjusting screw.

Checking the Idling speed

- Idle speed should be set to 3,000 rpm.
If necessary correct it by means of the idle screw (the nylon cutting head must not turn when the engine is on idle).
Screwing in the screw (1) will cause an increase in the engine speed, whereas backing off the screw will reduce the engine speed.

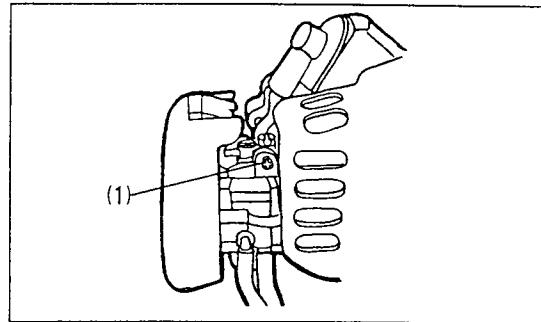

NYLON CUTTING HEAD

The nylon cutting head is a dual string trimmer head capable of bump & feed mechanisms.

The nylon cutting head will automatically feed out the proper length of nylon cord by the changes in centrifugal force caused by increasing or decreasing RPMS. However, to cut soft grass more efficiently, bump the nylon cutting head against the ground to feed out extra cord as indicated under operation section.

Operation

- Increase the nylon cutting head speed to approx. 6,000 rpm.
Low speed (under 4,800 rpm) is not suitable, the nylon cord will not feed out properly at low speed.
- The most effective cutting area is shown by the shaded area.

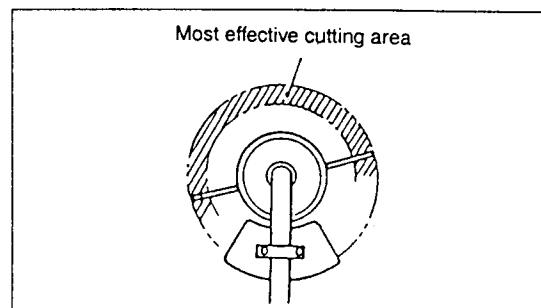

If the nylon cord does not feed out proceed as follows:

1. Release the control lever to run the engine idle and then squeeze the control lever fully. Repeat this procedure until the nylon cord feeds out to the proper length.
2. If the nylon cord is too short to feed out automatically with the above procedure, bump the knob of the nylon cutting head against the ground to feed out the nylon cord.
3. If the nylon cord does not feed out with procedure 2, rewind/replace the nylon cord by following the procedures described under "Replacing the nylon cord".

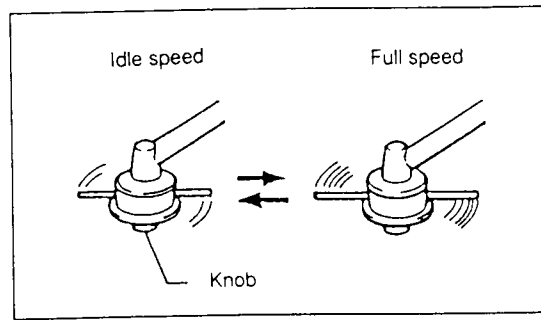

Replacing the nylon cord

- First, stop the engine.
- Press on the housing latches inward to lift off the cover, then remove the spool.

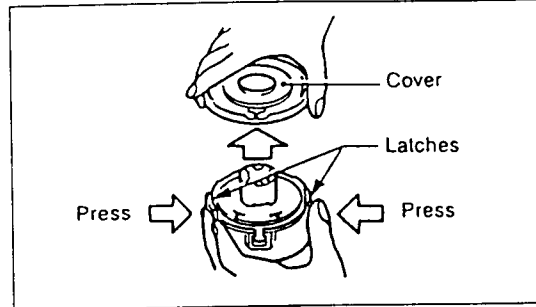

- Hook the center of new nylon cord into the notch in the center of the spool, with one end of the cord extending about 80mm (3-1/8") more than the other. Then wind both ends firmly around the spool in the direction of the head rotation (left-hand direction indicated by LH and right-hand direction by RH on the side of the spool).

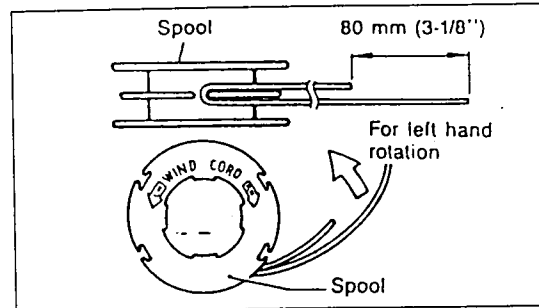

- Wind all but about 100mm (3-15/16") of the cords, leaving the ends temporarily hooked through a notch on the side of the spool.

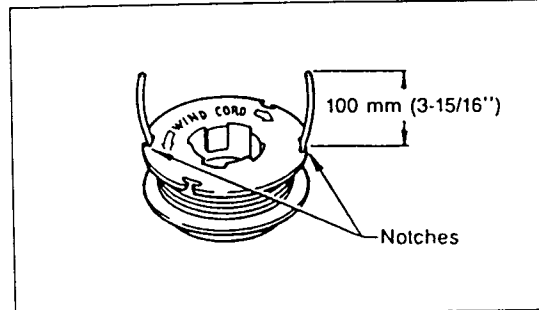

- Mount the spool in the housing so that the grooves and protrusions on the spool match up with those in the housing. Keep the side with letters on the spool visible on the top. Now, unhook the ends of the cord from their temporary position and feed the cords through the eyelets to come out of the housing.

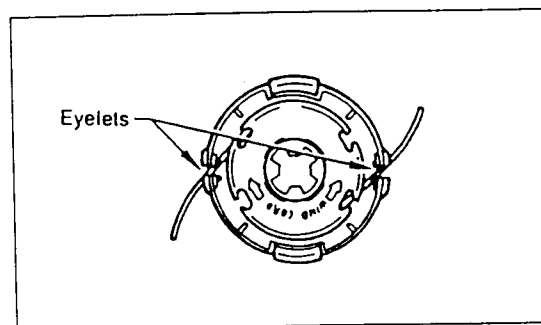

- Align the protrusion on the underside of the cover with the slots of the eyelets. Then push cover firmly onto the housing to secure it.

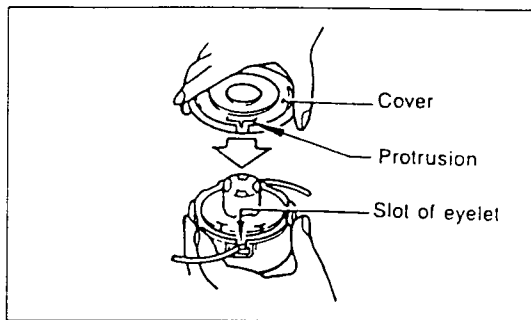

SERVICING INSTRUCTIONS



CAUTION: Before doing any work on the string trimmer, always switch off the engine and pull the plug cap off the spark plug (see "checking the spark plug").
Always wear protective gloves!

To ensure a long service life and to avoid any damage to the equipment, the following servicing operations should be performed at regular intervals.

Daily checkup and maintenance

- Before operation, check the machine for loose screws or missing parts. Pay particular attention to the tightness of the nylon cutting head.
- Before operation, always check for clogging of the cooling air passage and the cylinder fins. Clean them if necessary.
- Perform the following work daily after use:
 - Clean the string trimmer externally and inspect for damage.
 - Clean the air filter. When working under extremely dusty conditions, clean the filter the several times a day.
 - Check the nylon cutting head for damage and make sure it is firmly mounted.
 - Check that there is sufficient difference between idling and engagement speed to ensure that the nylon cutting head is at a standstill while the engine is idling (if necessary reduce idling speed).
- If under idling conditions the tool should still continue to run, consult your nearest Authorized Service Agent.
- Check the functioning of the I-O switch, the lock-off lever, the control lever, and the lock button.

Cleaning of air cleaner

- Remove the air cleaner cover.

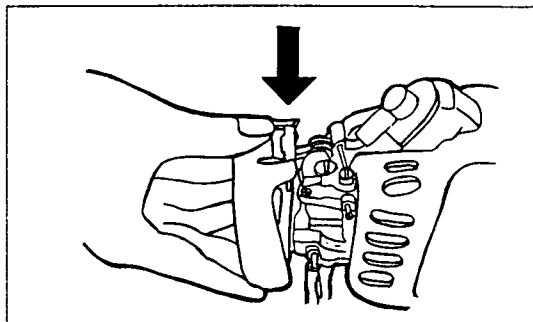

- Take out the sponge element (3), wash it in lukewarm water and dry it completely.
- After cleaning, put back the air cleaner cover (4).

NOTE: If there is excessive dust or dirt adhering to the air cleaner, clean it every day. A clogged air cleaner may make it difficult or impossible to start the engine or increase the engine rotational speed.

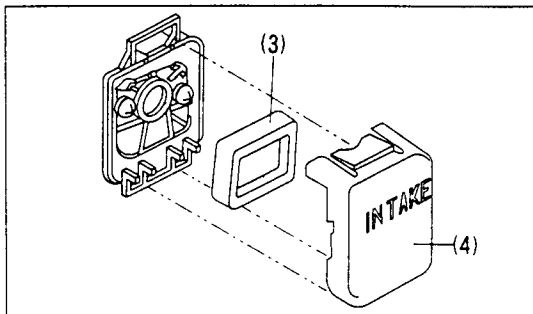

Checking the spark plug

- Only use the supplied universal wrench to remove or to install the spark plug.
- The gap between the two electrodes of the spark plug should be 0.6 - 0.7 mm (0.024" - 0.028"). If the gap is too wide or too narrow, adjust it. If the spark plug is clogged with carbon or fouled, clean it thoroughly or replace it.

CAUTION: Never touch the spark plug connector while the engine is running (danger of high voltage electric shock).

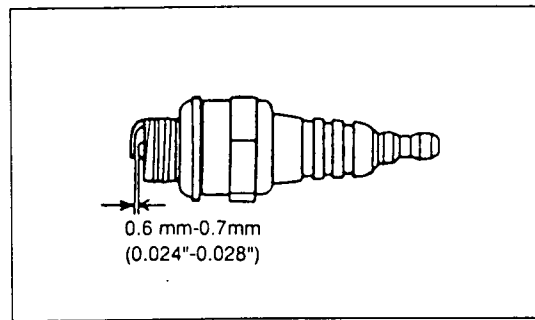

Supply of grease to gear case

- Supply grease (Shell Alvania 3 or equivalent) to the gear case through the grease hole every 30 hours. (Genuine MAKITA grease may be purchased from your MAKITA dealer.)

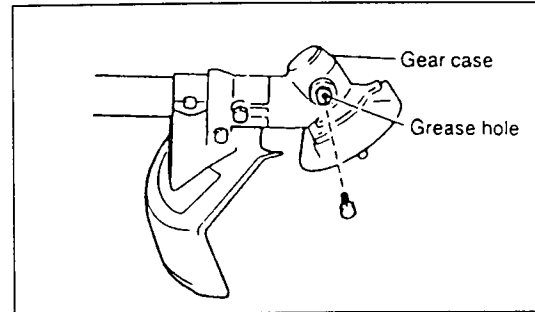

Suction head in the fuel tank

- The felt filler (1) of the suction head is used to filter the fuel required by the carburetor.
- A periodical visual inspection of the felt filter is to be conducted. For that purpose open the tank cap, use a wire hook and pull out the suction head through the tank opening. Filters found to have hardened, been polluted or clogged up are to be replaced.
- Insufficient fuel supply can result in the admissible maximum speed being exceeded. It is therefore important to replace the felt filter at least quarterly to ensure satisfactory fuel supply to the carburetor.

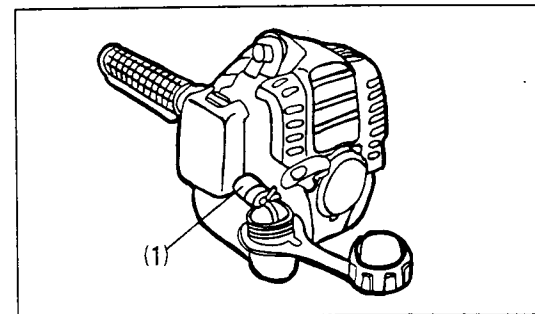

Cleaning of muffler exhaust port

- Check of muffler exhaust port (2) regularly.
- If it is clogged by carbon deposits, carefully scratch the deposits out with a suitable tool.

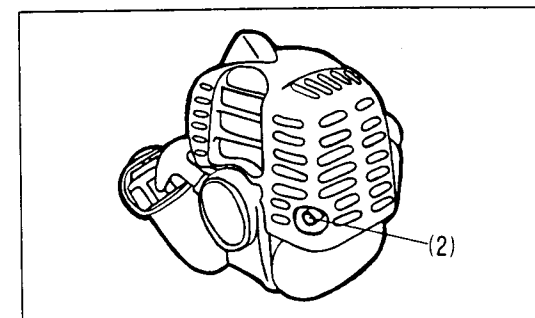

Any maintenance or adjustment work that is not included and described in this manual is only to be performed by Authorized Service Agents.

STORAGE

- When the machine is in storage for a long time, drain fuel from the fuel tank and carburetor, as follows: Drain all fuel from the fuel tank. Dispose of properly and in accordance with all local laws.
- Remove the spark plug and a few drops of oil into the spark plug hole. Then, pull the starter gently, so that oil covers the engine inside and tighten the spark plug.
- Clear dirt or dust from the nylon cutting head and outside of engine, wipe them with a oil-immersed cloth and keep the machine in a place as dry as possible.

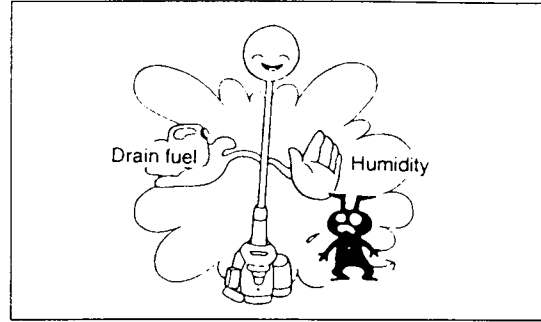

Maintenance schedule

General	Engine assembly, screws and nuts	Visual inspection for damage and tightness Check for general condition and security
After each refuelling	Control lever I-O-switch	Functional check Functional check
Daily	Air filter Cooling air duct Cutting tool Idling speed	To be cleaned To be cleaned Check for damage Inspection (cutting tool must not move)
Weekly	Spark plug Muffler	Inspection, replace if necessary Check and if necessary clean the opening
Quarterly	Suction head Fuel tank	To be replaced To be cleaned
Shutting down procedure	Fuel tank Carburetor	Empty fuel tank Operate until engine runs out of fuel

Fault location

Fault	System	Observation	Cause
Engine not starting or with difficulty	Ignition system	Ignition spark O.K.	Fault in fuel supply or compression system, mechanical defect
		No ignition spark	STOP-switch operated, wiring fault or short circuit, spark plug or connector defective, ignition module faulty
	Fuel supply	Fuel tank filled	Incorrect choke position, carburetor defective, fuel supply line bent or blocked, fuel dirty.
	Compression	No compression when pulled over	Cylinder bottom gasket defective, crankshaft seals damaged, cylinder or piston rings defective or improper sealing of spark plug
Warm start problems	Mechanical fault	Starter not engaging	Broken starter spring, broken parts inside of the engine
		Tank filled ignition spark existing	Carburetor contaminated, have it cleaned
Engine starts but dies	Fuel supply	Tank filled	Incorrect idling adjustment, carburetor contaminated Fuel tank vent defective, fuel supply line interrupted, cable or STOP-switch faulty
Insufficient performance	Several systems may simultaneously be affected	Engine idling poor	Air filter contaminated, carburetor contaminated, muffler clogged, exhaust duct in the cylinder clogged

California Emission Control Warranty Statement

[This warranty does not apply in any other state.]

YOUR WARRANTY RIGHTS AND OBLIGATIONS

The California Air Resources Board and Makita U.S.A., Inc. are pleased to explain the emission control warranty on your 1995 and later utility and/or lawn and garden equipment engine. In California, new utility and lawn and garden equipment engine must be designed, built and equipped to meet the State's stringent anti-smog standards. Makita U.S.A., Inc. must warrant the emission control system on your utility and/or lawn and garden equipment engine for the periods of time listed below provided there has been no abuse, neglect or improper maintenance of your utility and/or lawn and garden equipment engine.

Your emission control system includes parts such as the carburetor or fuel injection systems, the ignition system and the catalytic converter. Also included are the hoses and connectors and other emission-related assemblies.

Where a warrantable condition exists, Makita U.S.A., Inc. will repair your utility and/or lawn and garden equipment at no cost to you including diagnosis, parts and labor.

MANUFACTURER'S WARRANTY COVERAGE:

The 1995 and later utility and/or lawn and garden equipment engines are warranted for two years. If any emission-related part on your engine is defective, the part will be repaired or replaced by Makita U.S.A., Inc.

OWNER'S WARRANTY RESPONSIBILITIES:

As the utility and lawn and garden equipment engine owner, you are responsible for the performance of the required maintenance listed in your owner's manual. Makita U.S.A., Inc. recommends that you retain all receipts covering maintenance on your utility and/or lawn and garden equipment engine, but Makita U.S.A., Inc. cannot deny warranty solely for the lack of receipts or for your failure to ensure the performance of all scheduled maintenance.

As the utility and/or lawn and garden equipment engine owner, you should be aware, however, that Makita U.S.A., Inc. may deny you warranty coverage if your utility and/or lawn and garden equipment engine or a part has failed due to abuse, neglect, improper maintenance or unapproved modifications.

You are responsible for presenting your utility and/or lawn and garden equipment engine to a Makita U.S.A., Inc. service center as a problem exists. The warranty repairs should be completed in a reasonable time, not to exceed 30 days.

If you have any questions regarding your warranty rights and responsibilities, you should contact a Makita Factory Service Center Manager nearest you. A list of the Factory Service Center locations and phone numbers is provided on page 20 for your convenience.

LIMITED WARRANTY

- California Only -

Makita U.S.A., Inc. a distributor of utility and lawn and garden equipment in the U.S., warrants to the owner of 1995 and later utility and/or lawn and garden equipment engines that the engine (1) has been designed, built, and equipped at the time of manufacture so as to conform with the applicable regulations of the California Air Resources Board, and (2) is free from defects in materials and workmanship which may cause it to fail to conform with those regulations as applicable according to the terms and conditions stated below.

WARRANTY PERIOD

The warranty period begins on the date which the utility and/or lawn and garden equipment engine is delivered to the original retail purchaser and ends two years after that date. During this two year period Makita U.S.A., Inc. warrants to the original retail purchaser and each subsequent purchaser that the engine is free from defect in material and workmanship that can cause the failure of a warranted emission-related part.

WHAT IS COVERED UNDER THIS WARRANTY

Repair and/or replacement of any warranted emission-related part will be performed at no charge provided the work is performed at an authorized warranty station. There will also be no charge for any diagnostic labor performed at an authorized warranty station which leads to the determination that a warranted emission-related part is defective.

Any warranted part which is not scheduled for replacement as required maintenance, or which is scheduled only for regular inspection to the effect of "repair or replace as necessary" shall be warranted for the warranty period. Any warranted part which is scheduled for replacement as required maintenance shall be warranted for the period of time up to the first scheduled replacement of the part. This warranty shall apply only towards the repair, replacement, and/or adjustment of the component parts listed below.

EMISSION-RELATED PARTS COVERED UNDER THIS WARRANTY

1. Fuel Metering Systems
 - (a) Carburetor and its internal parts
 - (b) Air cleaner plate
 - (c) Air cleaner case
 - (d) Air cleaner element
 - (e) Fuel filter
2. Ignition Systems
 - (a) Spark Plug
 - (b) Flywheel Magneto
 - (c) Ignition Coil
3. Other Miscellaneous Items Used in Above Systems
 - (a) Fuel Hoses
 - (b) Sealing Gaskets

If it is determined by an authorized warranty station that other engine components have been damaged due to the failure of a warranted emission-related part during the warranty period, Makita U.S.A., Inc. will repair and/or replace the necessary components.

WHAT IS NOT COVERED UNDER THIS WARRANTY

This warranty does not cover any emission-related part which malfunctions, fails, or is damaged due to alterations and/or modifications such as changing, adding, or removing parts.

When an engine is being serviced under warranty, Makita U.S.A., Inc. and any of its authorized dealers, distributors, or warranty stations shall not be liable for any loss of use of the engine, for any damage to goods, or loss of time or inconvenience.

This limited warranty also does not apply to any emission-related part which malfunctions, fails, or is damaged due to failure to follow the maintenance and operating instructions specified in the 1995 and later Owner's Manual including:

- (a) Improper or inadequate maintenance of any warranted emission-related part.
- (b) Improper installation, adjustment, or repair of the engine or any warranted emission-related part unless performed by a factory authorized warranty station.
- (c) Failure to use recommended fuel as specified in the 1995 and later Owner's Manual.
- (d) Repairs and diagnosis performed outside of an authorized warranty station.
- (e) Use of parts which are not authorized by Makita U.S.A., Inc.

MAINTENANCE SCHEDULE

The engine owner is responsible for having all scheduled inspection and maintenance services performed at the intervals specified in the 1995 and later Owner's Manual and to retain records of these services as having been performed. These records should be transferred to each subsequent owner of the engine. Makita U.S.A., Inc., cannot deny a claim solely because there are no records of scheduled maintenance; however, a warranty claim may be denied if the failure to perform the scheduled maintenance and inspection resulted in the failure of a warranted emission-related part. As a minimum, the engine owner is responsible for the scheduled inspection and maintenance described below which are based on the procedures described in the Owner's Manual.

PROCEDURE

- (a) Check all nuts and bolts and tighten as necessary
- (b) Check air passages and engine cylinder fins for clogging.
Remove all obstructions as necessary.
- (c) Clean air cleaner.
- (d) Check the spark plug. Clean and adjust it if necessary.
- (e) Check the muffler exhaust port. Clean it if necessary.
- (f) Check the fuel filter. If clogged, replace it with new filter.
- (g) Replace fuel lines.
- (h) Overhaul the engine.
- (i) Replace the packings and gaskets.

INTERVAL

- Every 8 hours of use or daily.
- Every 8 hours of use or daily.
- Every 8 hours of use or daily.
- Every 8 hours of use or daily.
- Every 50 hours of use or monthly.
- Every 50 hours of use or monthly.
- Every 200 hours of use or annually.
- Every 200 hours of use or annually.
- Every time the engine is reassembled.

REPAIR AND REPLACEMENT OF EMISSION-RELATED PARTS

It is recommended that only engine replacement parts which have been authorized and approved by Makita U.S.A., Inc. should be used in the performance of any warranty maintenance or repairs of emission-related parts. These replacement parts will be provided at no charge if the part is still under warranty.

HOW TO FILE A WARRANTY CLAIM AND WHERE TO GET WARRANTY SERVICES

Contact the nearest Makita Factory Service Center Manager to determine the appropriate location where the required warranty services are to be performed. A list of the Factory Service Center locations and phone numbers are provided below for your convenience.

14930 Northam Street
La Mirada, CA 90638-5753
(714) 522-8088

41850 Christy Street
Fremont, CA 94538-5107
(510) 657-9881

1421N. Clovis Ave., Ste. 112
Fresno, CA 93727
(209) 252-5166

7674 Clairemont Mesa Blvd.
San Diego, CA 92111
(619) 278-4471

1440 South "E" Street
San Bernardino, CA 92408
(909) 885-1289

1714 E McFadden Ave., Unit M
Santa Ana, CA 92705
(714) 667-5066

16735 Saticoy St., Ste. 105
Van Nuys, CA 91406
(818) 782-2440

1565 Winchester Blvd.
Campbell, CA 95008-0501
(408) 379-0377

1970 Fulton Avenue
Sacramento, CA 95825
(916) 482-5197

FEDERAL EMISSION COMPONENT DEFECT WARRANTY

EMISSION COMPONENT DEFECT WARRANTY COVERAGE - This emission warranty is applicable in all States, except the State of California

Makita U.S.A., Inc., La Mirada, California, (herein "MAKITA") warrant to the initial retail purchaser and each subsequent owner, that this utility equipment engine (herein "engine") was designed, built, and equipped to conform at the time of initial sale to all applicable regulations of the U.S. Environmental Protection Agency (EPA), and that the engine is free of defects in materials and workmanship which would cause this engine to fail to conform with EPA regulations during its warranty period.

For the components listed under PARTS COVERED, Makita Factory Service Center or service center authorized by MAKITA will, at no cost to you, make the necessary diagnosis, repair, or replacement necessary to ensure that the engine complies with applicable U.S. EPA regulations.

EMISSION COMPONENT DEFECT WARRANTY PERIOD

The warranty period for this engine begins on the date of sale to the initial purchaser and continues for a period of 2 years.

PARTS COVERED

Listed below are the parts covered by the Emission Component Defect Warranty. Some of the parts listed below may require scheduled maintenance and are warranted up to the first scheduled replacement point for that part.

- 1) Fuel Metering System
 - (i) Carburetor and internal parts
 - (ii) Fuel filter, if applicable
 - (iii) Throttle stopper, if applicable
 - (iv) Choke System, if applicable
- 2) Air Induction System
 - (i) Air cleaner plate
 - (ii) Air cleaner case
 - (iii) Air cleaner element
- 3) Ignition System
 - (i) Spark plug
 - (ii) Flywheel Magneto
 - (iii) Ignition Coil
- 4) Miscellaneous Items Used in Above Systems
 - (i) Fuel hoses, clamps and sealing gaskets

OBTAINING WARRANTY SERVICE

To obtain warranty service, take your engine to the nearest Makita Factory Service Center or Service Center authorized by MAKITA. Bring your sales receipts indicating date of purchase for this engine. The dealer or service center authorized by MAKITA will perform the necessary repairs or adjustments within a reasonable amount of time and furnish you with a copy of the repair order. All parts and accessories replaced under this warranty become the property of MAKITA.

WHAT IS NOT COVERED

- * Conditions resulting from tampering, misuse, improper adjustment (unless they were made by the dealer or service center authorized by MAKITA during a warranty repair), alteration, accident, failure to use the recommended fuel and oil, or not performing required maintenance services.
- * The replacement parts used for required maintenance services.
- * Consequential damages such as loss of time, inconvenience, loss of use of the engine of equipment, etc.
- * Diagnosis and inspection charges that do not result in warranty-eligible service being performed.
- * Any non-authorized replacement part, or malfunction of authorized parts due to use of non-authorized parts.

OWNER'S WARRANTY RESPONSIBILITIES

As the engine owner, you are responsible for the performance of the required maintenance listed in your owner's manual, MAKITA recommends that you retain all receipts covering maintenance on your engine, but MAKITA can not deny warranty solely for the lack of receipts or for your failure to ensure the performance of all scheduled maintenance.

As the engine owner, you should however be aware that the MAKITA may deny your warranty coverage if your engine or a part has failed due to abuse, neglect, improper maintenance or unapproved modifications.

You are responsible for presenting your engine to the nearest Makita Factory Service Center or service center authorized by MAKITA when a problem exists.

If you have any questions regarding your warranty rights and responsibilities, you should contact the Makita Warranty Service Department at 1-800-4-MAKITA for the information.

THINGS YOU SHOULD KNOW ABOUT THE EMISSION CONTROL SYSTEM WARRANTY

MAINTENANCE AND REPAIRS

You are responsible for the proper use and maintenance of the engine. You should keep all receipts and maintenance records covering the performance of regular maintenance in the event questions arise. These receipts and maintenance records should be transferred to each subsequent owner of the engine. MAKITA reserves the rights to deny warranty coverage if the engine has not been properly maintained. Warranty claims will not be denied, however, solely because of the lack of required maintenance or failure to keep maintenance records.

MAINTENANCE, REPLACEMENT OR REPAIR OF EMISSION CONTROL DEVICES AND SYSTEMS MAY BE PERFORMED BY ANY REPAIR ESTABLISHMENT OR INDIVIDUAL; HOWEVER, WARRANTY REPAIRS MUST BE PERFORMED BY MAKITA FACTORY SERVICE CENTER OR SERVICE CENTER AUTHORIZED BY MAKITA. THE USE OF PARTS THAT ARE NOT EQUIVALENT IN PERFORMANCE AND DURABILITY TO AUTHORIZED PARTS MAY IMPAIR THE EFFECTIVENESS OF THE EMISSION CONTROL SYSTEM AND MAY HAVE A BEARING ON THE OUTCOME OF WARRANTY CLAIM.

If other than the parts authorized by MAKITA are used for maintenance replacements or for the repair of components affecting emission control, you should assure yourself that such parts are warranted by their manufacturer to be equivalent to the parts authorized by MAKITA in their performance and durability.

HOW TO MAKE A CLAIM

All repairs qualifying under this limited warranty must be performed by Makita Factory Service Center or service center authorized by MAKITA. In the event that any emission-related part is found to be defective during the warranty period, you shall notify Makita Warranty Service Department at 1-800-4-MAKITA and you will be given the appropriate warranty service facilities where the warranty repair can be performed.



WARNING: The Engine Exhaust from this product contains chemicals known to the state of California to cause cancer, birth defects or other reproductive harm.

Makita Corporation

3-11-8, Sumiyoshi-cho,
Anjo, Aichi 446-8502, Japan

Free Manuals Download Website

<http://myh66.com>

<http://usermanuals.us>

<http://www.somanuals.com>

<http://www.4manuals.cc>

<http://www.manual-lib.com>

<http://www.404manual.com>

<http://www.luxmanual.com>

<http://aubethermostatmanual.com>

Golf course search by state

<http://golfingnear.com>

Email search by domain

<http://emailbydomain.com>

Auto manuals search

<http://auto.somanuals.com>

TV manuals search

<http://tv.somanuals.com>