



NETWORK
TECHNOLOGIES
INCORPORATED

1275 Danner Dr Tel:330-562-7070
Aurora, OH 44202 Fax:330-562-1999
www.networktechinc.com

XTENDEX™ Series

ST-C5VA-WL500

WALL MOUNT VGA VIDEO AND STEREO AUDIO EXTENDER

Installation and Operation Manual



TRADEMARK

XTENDEX is a trademark of Network Technologies Inc in the U.S. and other countries.

COPYRIGHT

Copyright © 2006 by Network Technologies Inc. All rights reserved. No part of this publication may be reproduced, stored in a retrieval system, or transmitted, in any form or by any means, electronic, mechanical, photocopying, recording, or otherwise, without the prior written consent of Network Technologies Inc, 1275 Danner Drive, Aurora, Ohio 44202.

CHANGES

The material in this guide is for information only and is subject to change without notice. Network Technologies Inc reserves the right to make changes in the product design without reservation and without notification to its users.

Note: *Shielded CAT 5,5e, or 6 cable must be used to connect to LOCAL and REMOTE units in order to meet CE emission requirements.*

Note: *CAT5 connection cable used between NTI XTENDEX Series Local and Remote or any XTENDEX Series products should not be run underground, outdoors or between buildings.*



WARNING: *Outdoor or underground runs of CAT5 cable could be dangerous and will void the warranty.*

TABLE OF CONTENTS

Introduction.....	1
Materials	1
Features and Functions.....	2
Limitations	3
Preparation for Installation	3
Installation	4
Installing The Local Unit	4
Connect The CAT5 Cable.....	4
Connect the CPU.....	5
Connect a Local User	6
Installing The Remote Unit	7
Attach Wall Mount Brackets.....	7
Connect Monitor and Speakers	7
Connect the CAT5 cable.....	8
Plug-in and Power Up.....	8
Video Quality	9
Technical Specifications.....	9
Interconnection Cable Wiring Method	10
Troubleshooting.....	10
Warranty Information.....	11

TABLE OF FIGURES

Figure 1- Install Local Unit to 2 gang outlet box.....	4
Figure 2- Connect the Local Unit to the CPU.....	5
Figure 3- Connect the local user to the XTENDEX Local Unit	6
Figure 4- Attach wall mount brackets to Remote Unit.....	7
Figure 5- Connect monitor and speakers to the Remote Unit.....	7
Figure 6- Connect the CAT5 cable to the Remote Unit.....	8
Figure 7- Connect the AC adapter to the Remote Unit	8
Figure 8- View looking into RJ45 female.....	10

INTRODUCTION

The XTENDEX Series Wall Mount VGA Video and Stereo Audio Extender (XTENDEX) is designed to enable the VGA video and stereo audio signals from one CPU to be viewed and heard by two users, one local and one remote. The remote user can be located as much as 500 feet away via Category 5 unshielded twisted-pair cable. The local user will be located near the CPU.

The XTENDEX Series Wall Mount VGA Video and Stereo Audio Extender is extremely simple to install and has been thoroughly tested to insure reliable performance. Through the use of Category 5 cable it is possible to economically increase the flexibility of a computer system. Here are some of the features and ways this can benefit any workplace:

- Allows the placement of computer monitor and speakers in a location where only these parts are needed without having the CPU there too, taking up valuable space
- Allows a CPU video and audio signal to be accessed by both a local and remote user (up to 500 feet away)
- Compatible with VGA, SVGA, and XGA systems
- Provides crisp and clear resolution up to 1024 x 768 @ 500 feet (see page 8 for more details)
- Compatible with all NTI switches and splitters, enabling the joining of products to create a system that satisfies all networking needs
- Video quality adjustment, for varying lengths of cable, is automatic providing optimum image quality
- Digital transmission of audio signals reduces any loss in quality

MATERIALS

Materials Included with this kit:

- ✓ NTI XTENDEX ST-C5VA-WL500 Local Unit
- ✓ NTI XTENDEX ST-C5VA-WL500 Remote Unit
- ✓ 120VAC or 240VAC at 50 or 60Hz-12VDC/1.0A AC Adapter
- ✓ VEXT-6 NTI 6 foot video cable with 15HD male on one end, 15HD female on the other end
- ✓ SA-6-MM NTI 6 foot audio cable with 3.5mm stereo audio plugs on each end
- ✓ 2- Wall Mount Brackets
- ✓ 4- 4-40x1/4" Flat Head Screws
- ✓ 4- 6-32x1/2" Flat Head Screws
- ✓ CD with a pdf file of this owner's manual
- ✓ NTI Product Registration Card

Additional materials may need to be ordered, depending upon the configuration:

- CAT5/5e/6 unshielded twisted-pair cable(s) terminated with RJ45 connectors wired straight thru- pin 1 to pin 1, etc. (see pg. 10 for proper EIA/TIA 568 B wiring method)

Contact your nearest NTI distributor or NTI directly for all of your KVM needs at 800-RGB-TECH (800-742-8324) in US & Canada or 330-562-7070 (Worldwide) or at our website at <http://www.networktechinc.com> and we will be happy to be of assistance.

ST-C5VA-WL500

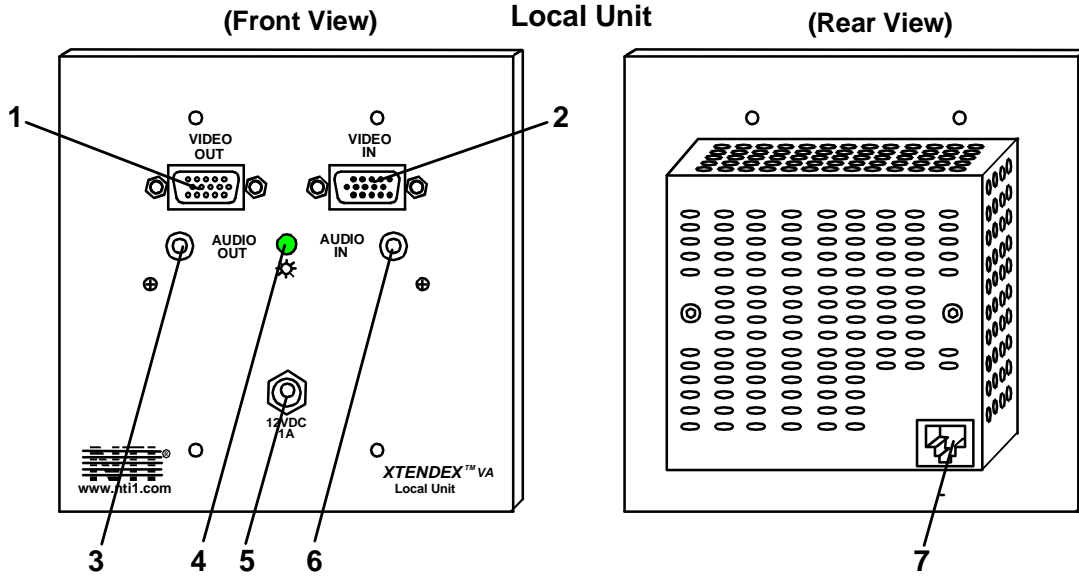

FEATURES AND FUNCTIONS

1. VIDEO OUT- 15HD female video connector- for connecting the local user's VGA monitor
2. VIDEO IN- 15HD male video connector- for connecting to the video port on the CPU or KVM switch
3. AUDIO OUT- 3.5mm stereo audio jack- for connecting to local speakers
4. Power Indicator LED- to indicate that power has been supplied to the XTENDEX
5. 12VDC- 1.0A- connection jack for the AC adapter
6. AUDIO IN- 3.5mm stereo audio jack- for connecting to the audio port on the CPU or audio source
7. Cat5- RJ45 female- for connecting the CAT5 cable to the Local Unit
8. Cat5- RJ45 female- for connecting the CAT5 cable to the Remote Unit
9. Yellow LED- traffic indicator- illuminates when there is communication between the Local and Remote Units.
10. Green LED- power indicator- illuminates when power has been supplied to the Remote Unit (supplied through the CAT5 cable)
11. Audio Jack- 3.5mm stereo audio jack- for connecting to remote speakers
12. Video Connector- 15HD female- for connecting the remote user's VGA monitor
13. Wall Mount Bracket- to be attached if wall mounting the Remote Unit
14. 4-40 x 1/4" Flat Head Phillips screws- (qty. 4 supplied)- for attaching Wall Mount Bracket to Remote Unit
15. 6-32 x 1/2" Flat Head Phillips screws- (qty. 4 supplied) - for attaching Local Unit to 2 gang outlet box

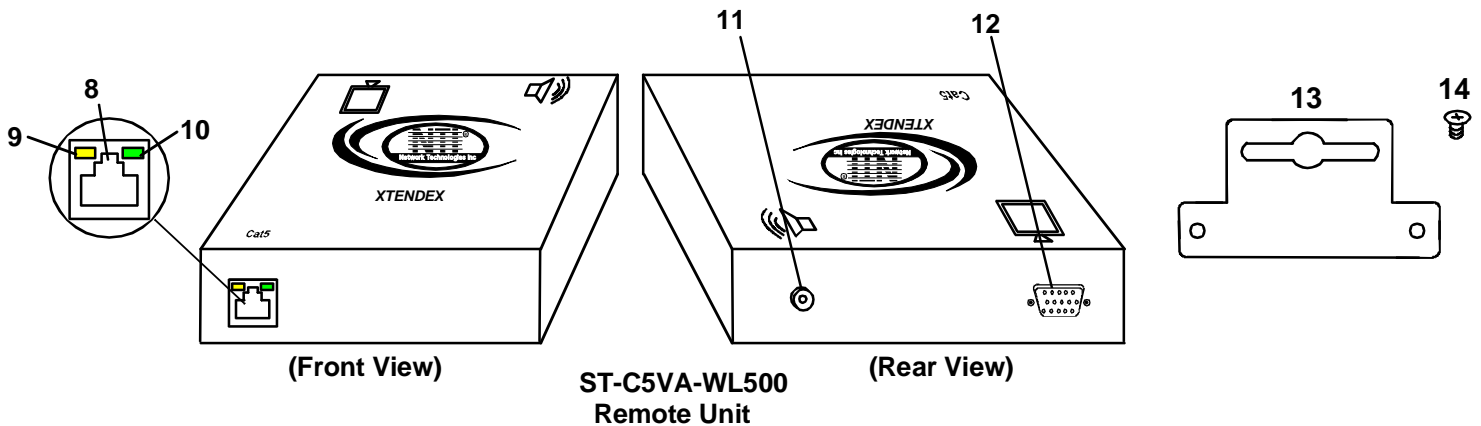

LIMITATIONS

- Hot-plugging of devices is supported provided devices were originally connected at power-up.
- The audio input of the XTENDEX is compatible with the following standard CPU audio outputs:
 - Line out - typically lime green in color
 - Speaker out- typically orange in color
 - Headphone out- typically located on the CD-ROM
- The audio output of the XTENDEX is compatible with self-powered stereo speakers.

PREPARATION FOR INSTALLATION

- Locations should be chosen for the monitors and speakers that also have space to connect the Remote Unit within the distance provided by the cables. If extension cables are needed, contact NTI for the cables required.
- The CAT5 cables must be run to the locations where the Remote and Local Units will be connected. Be careful to route the cables away from any sources of magnetic fields or electrical interference that might reduce the quality of the video signal (i.e. AC motors, welding equipment, etc.).
- All cables should be installed in such a way that they do not cause stress on their connections to the equipment. Extended lengths of cable hanging from a connection may interfere with the quality of that connection. Secure cables as needed to minimize this.
- Properly shut down and disconnect the power from the CPU, monitors, and speakers to be separated. If other equipment is involved whose connections are being interrupted, be sure to refer to the instruction manuals for that equipment for proper disconnection and re-connection procedures before proceeding.

Note: CAT5 connection cable used between NTI XTENDEX Series Local and Remote or any XTENDEX Series products should not be run underground, outdoors or between buildings.



WARNING: Outdoor or underground runs of CAT5 cable could be dangerous and will void the warranty.

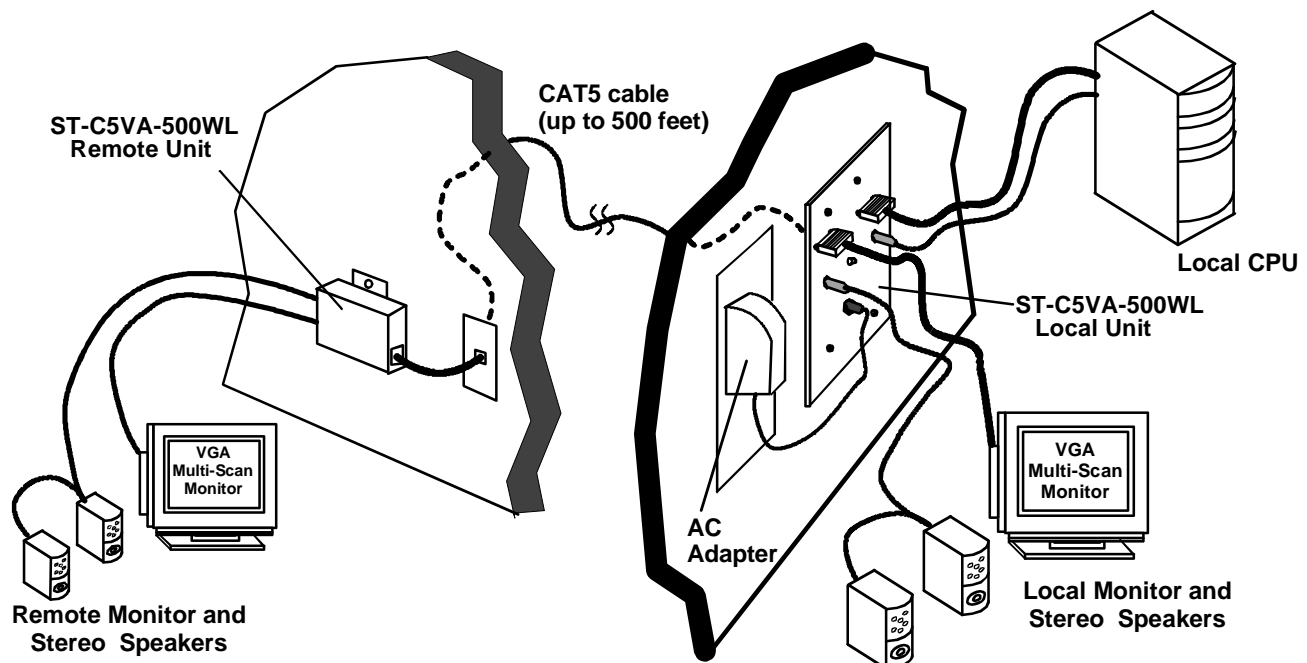

Typical Application

INSTALLATION

Installing The Local Unit

Connect The CAT5 Cable

A CAT5 cable with an RJ45 connector wired straight through (see specification on page 10) should extend from a UL Listed 2 gang electrical box at least far enough to make connection to the RJ45 connector on the back of the Local Unit (see Fig. 1). The outlet box must be at least 2 inches deep.

1. Connect the CAT5 cable to the Local Unit. When properly inserted the cable end should snap into place.



WARNING: Never connect the XTENDEX to an Ethernet card, Ethernet router, hub or switch or other Ethernet RJ45 connector of an Ethernet device. Damage to devices connected to the Ethernet may result.

2. Secure the Local Unit to the 2 gang outlet box using the 6-32X1/2" Phillips Flat Head screws (4) provided.

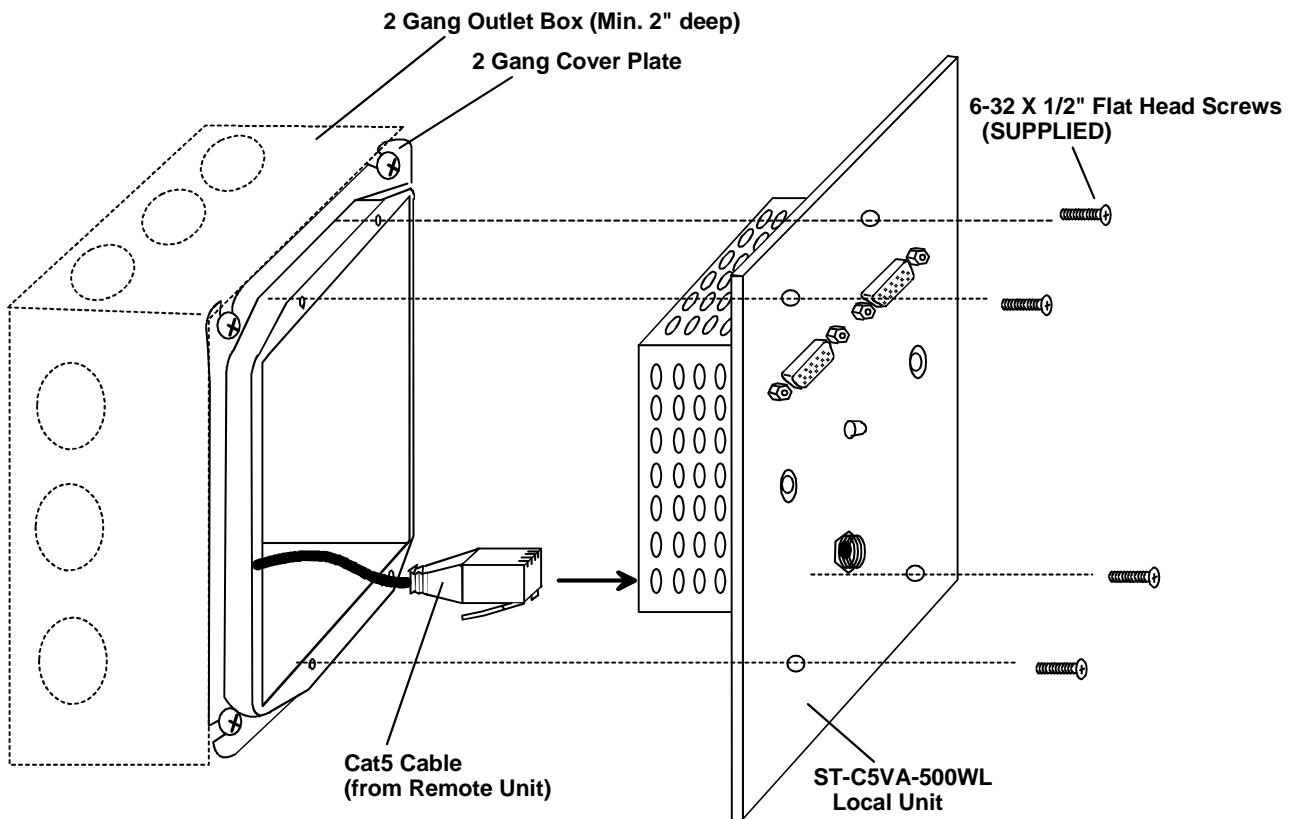

Figure 1- Install Local Unit to 2 gang outlet box

Connect the CPU

1. Connect the VEXT-6 video cable (provided) to the male 15HD connector on the Local Unit labeled "VIDEO IN". Connect the other end of the cable to the video port on the CPU (see Fig. 2).
2. Connect the SA-6-MM audio cable (provided) between the connector on the Local Unit labeled "AUDIO IN" and the audio output jack on the CPU marked "line out", "spkr", or "headphones" (see Fig. 2).

Notes:

If all 3 jacks are available, use the jack marked "line out".

The "line out" jack is typically lime green and may be marked with this symbol 

The "spkr" jack is typically orange, and may be marked with this symbol 

The "headphones" jack may be marked with this symbol 

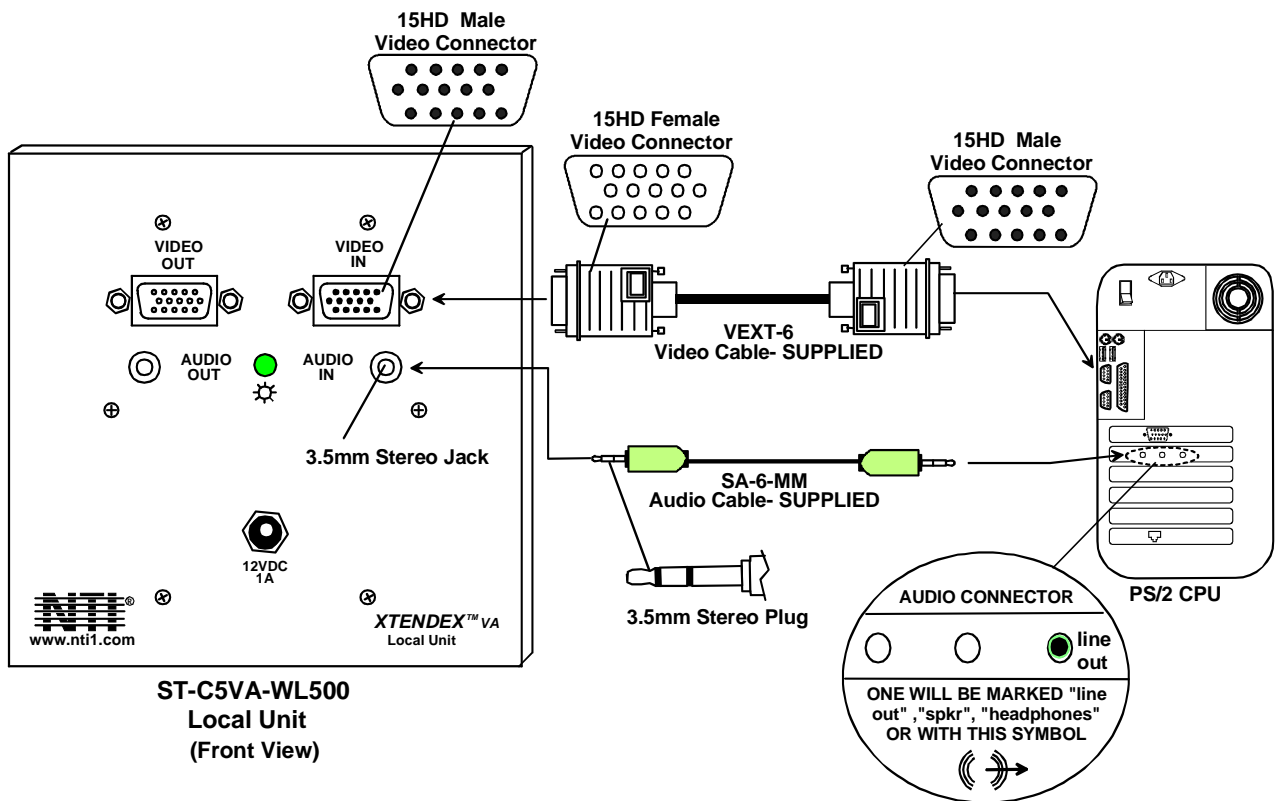

Figure 2- Connect the Local Unit to the CPU

Connect a Local User

(Optional)

1. Connect the cable from the local user's VGA monitor to the female 15HD connector labeled "VIDEO OUT" on the Local Unit.
2. Connect the cable from the local speakers to the 3.5mm stereo audio jack labeled "AUDIO OUT" on the Local Unit.

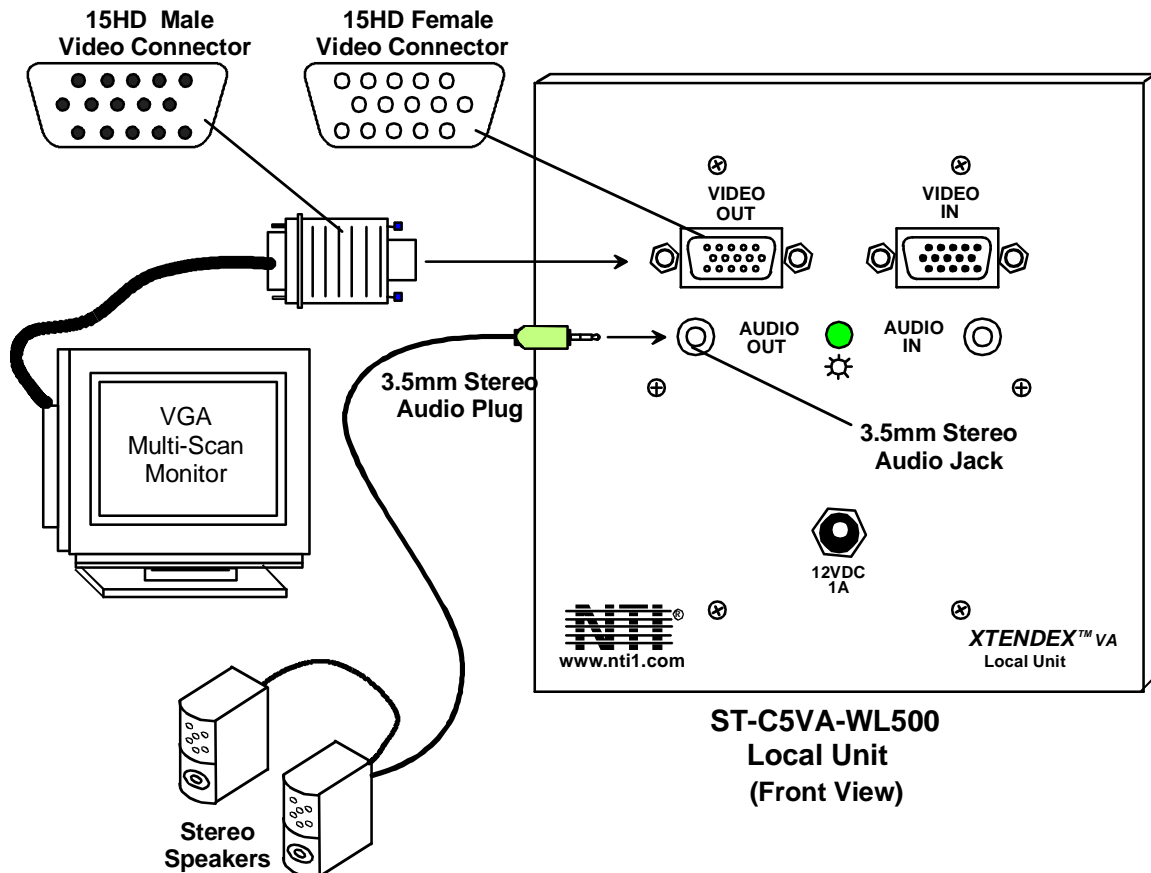

Figure 3- Connect the local user to the XTENDEX Local Unit

Installing The Remote Unit

The Remote Unit can either set on a desk near the monitor and speakers to be connected, or it can be mounted to a vertical surface using the wall mount brackets provided.

Attach Wall Mount Brackets

The two wall mount brackets can be secured to the Remote Unit using the four #4-40 x 1/4" screws provided (see Fig. 4). With the brackets attached, mount the Remote Unit to any desired surface using suitable hardware (not included). Be sure to position the Remote Unit such that the CAT5 cable, the monitor cable, and the speakers cable can each reach the Remote Unit without putting strain on the cables.

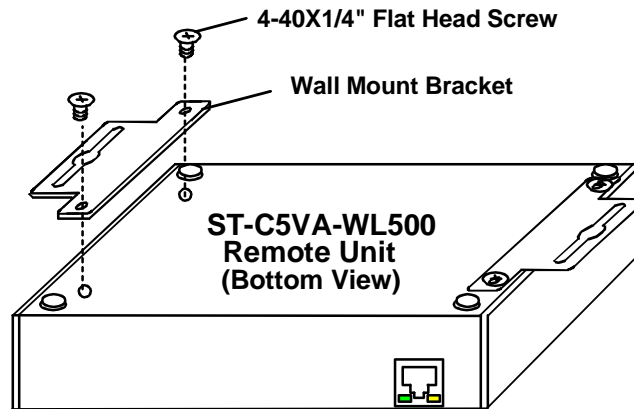

Figure 4- Attach wall mount brackets to Remote Unit

Connect Monitor and Speakers

1. Position the Remote Unit such that the CAT5 cable, the monitor cable, and the stereo audio cable can each reach the Remote Unit without putting strain on the cables.
2. Connect the monitor cable to the female 15HD video connector on the Remote Unit.
3. Connect the cable from the remote speakers to the 3.5mm stereo audio jack on the Remote Unit (see Fig. 5).

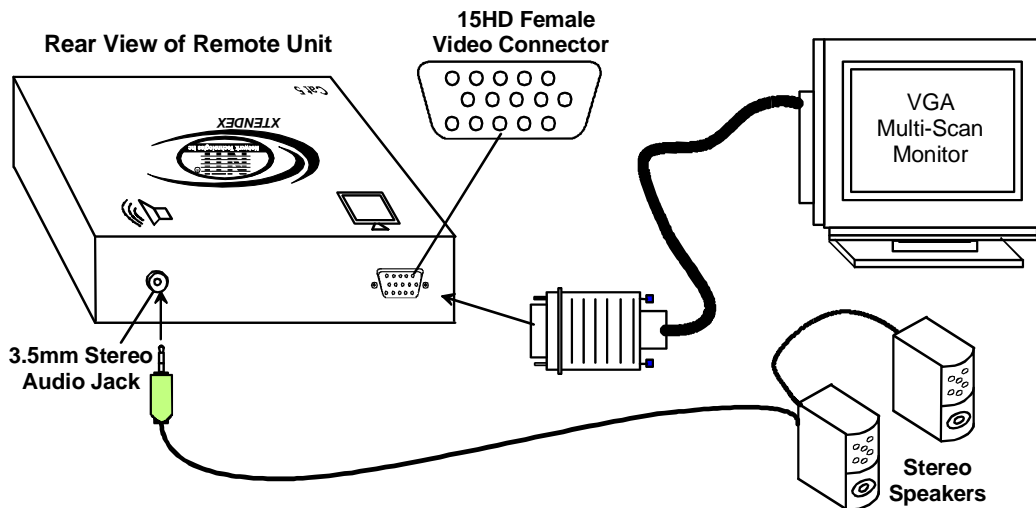

Figure 5- Connect monitor and speakers to the Remote Unit

Connect the CAT5 cable

Make sure the CAT5 cable has been installed in accordance with the “Preparation for Installation” instructions on page 3. Connect the CAT5 cable to the “Cat 5” port on the Remote Unit (see Fig. 6). When properly inserted the CAT5 cable end should snap into place.



WARNING: Never connect the XTENDEX to an Ethernet card, Ethernet router, hub or switch or other Ethernet RJ45 connector of an Ethernet device. Damage to devices connected to the Ethernet may result.

Note: The yellow LED on the RJ45 connector on the Remote Unit will illuminate anytime data traffic is passing between the Local and Remote Units.

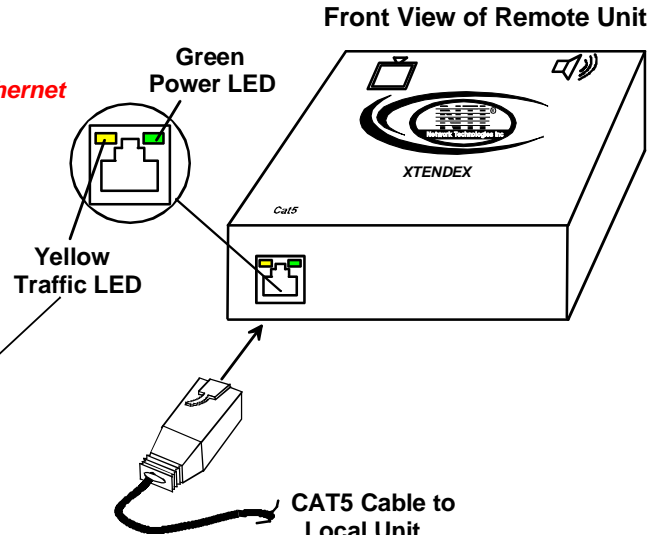

Figure 6- Connect the CAT5 cable to the Remote Unit

Plug-in and Power Up

1. Plug the power cord from the monitors into power outlets. Also power up the speakers if they have external power supplies.
2. Connect the 12VDC AC adapter power connector to the 12VDC port on the Local Unit (see Fig. 7). Plug the AC adapter into a power outlet. The green LED on the RJ45 connector of the Remote Unit and the power LED on the wallplate of the Local Unit should each illuminate, indicating that a proper power connection has been made to them (see Fig. 6). (The Remote Unit is powered by the Local Unit through the CAT5 cable.)
3. Turn ON the CPU and Monitors. They should each react as if they were directly connected to each other.

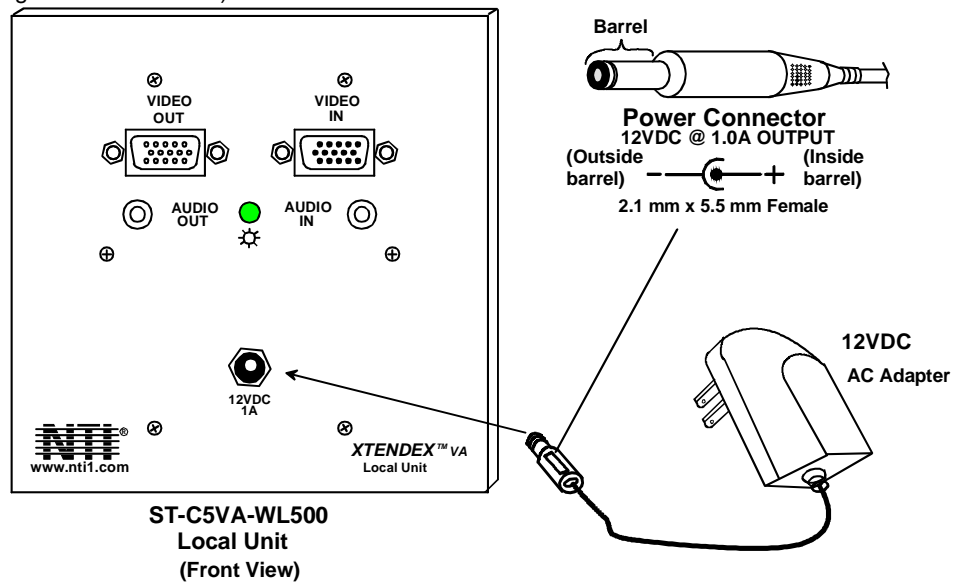

Figure 7- Connect the AC adapter to the Remote Unit

VIDEO QUALITY

Automatic Video Quality Adjustment

Video quality adjustment is done automatically to assure the image is as clear as possible.

Note: When the cable is longer than 300 feet some colored lines can be seen at the black-to-white transitions. This is a normal behavior and is caused by the different twisting rates of each pair of wires in the CAT5 cable.

TECHNICAL SPECIFICATIONS

Video	
Video Compatibility	VGA, SVGA, XGA
Video Coupling	DC
Video Connectors	HD15 male to CPU HD15 female to monitor
Input / Output Impedance	75 Ohms
Input Horizontal Frequency Range	15kHz to 130 Hz
Input Vertical Frequency Range	30 Hz to 150 Hz
Sync Types Supported	Separate and composite TTL Level and sync on green
Video Maximum I/O Levels	1.45Vp-p
Audio	
Audio Connectors	3.5mm stereo jack to speakers 3.5mm stereo jack to CPU
Signal Type	Line Level, stereo, unbalanced
Audio Frequency Response	20Hz to 20Khz, \pm 2dB
Signal-to-noise ratio	73 dBA
Total Harmonic Distortion and Noise	0.011%
Stereo Crosstalk	-69 dB
Audio Maximum I/O Levels	3.1Vp-p
Output Impedance	Max 2K Ohms, unbalanced
General	
Interconnect Cable (General applications)	CAT5/5e/6 Solid UTP EIA/TIA 568 B wiring w/ male RJ45 connectors
Interconnect Cable (CE applications)	CAT5/5e/6 Solid STP EIA/TIA 568 B wiring w/ male RJ45 connectors
Local Unit Power	120V or 240V at 50 or 60Hz-12VDC/1.0A via AC Adapter
Remote Unit Power	Powered by Local Unit
Local Unit Size (In.) WxDxH	4.5x1.4x4.5
Remote Unit Size (In.) WxDxH	3.5x3.1x1.2

Distances and Resolutions for CAT5/CAT5e and CAT6 Cables Unshielded Twisted Pair (UTP) Resolutions

UTP CABLE	DISTANCE (feet)	RESOLUTION
CAT5/CAT5e	500	1024x768 at 60Hz
CAT5/CAT5e	400	1280x1024 at 60Hz
CAT5/CAT5e	300	1600x1200 at 60Hz
CAT5/CAT5e	100	1920x1440 at 60Hz
CAT6	300	1024x768 at 60Hz
CAT6	200	1280x1024 at 60Hz
CAT6	100	1920x1440 at 60Hz

INTERCONNECTION CABLE WIRING METHOD

The CAT5 connection cable between the remote and local is terminated with RJ45 connectors and must be wired according to the EIA/TIA 568 B industry standard. Wiring is as per the table and drawing below.

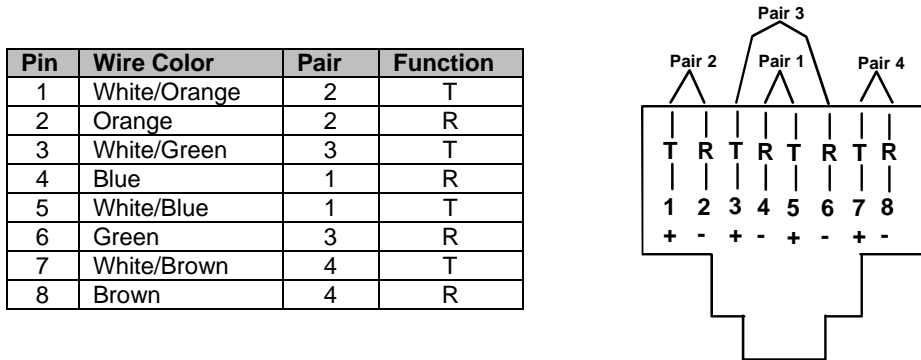

Figure 8- View looking into RJ45 female

Note: *Shielded CAT 5,5e, or 6 cable must be used to connect to LOCAL and REMOTE units in order to meet CE emission requirements.*

Note: *CAT5 connection cable used between NTI XTENDEX Series Local and Remote or any XTENDEX Series products should not be run underground, outdoors or between buildings.*



WARNING: *Outdoor or underground runs of CAT5 cable could be dangerous and will void the warranty.*

TROUBLESHOOTING

Each and every piece of every product produced by Network Technologies Inc is 100% tested to exacting specifications. We make every effort to insure trouble-free installation and operation of our products. If problems are experienced while installing this product, please look over the troubleshooting chart below for answers to any questions that might arise. If the answer is not found in the chart, please check the FAQs (Frequently Asked Questions) at our website at <http://www.networktechinc.com> or contact us directly for help at 1-800-742-8324 (800-RGB-TECH) in US & Canada or 1-330-562-7070 worldwide. We will be happy to assist in any way we can.

Problem	Cause	Solution
Remote or Local Unit power indicator LED does not illuminate	<ul style="list-style-type: none"> Power supply is not connected or plugged-in. 	<ul style="list-style-type: none"> Make sure outlet is live and AC adapter is plugged-in. Make sure 12VDC power connector is fully inserted Make sure CAT5 cable is connected at both ends (Remote Unit is powered via the CAT5 cable)
No Video on monitor	<ul style="list-style-type: none"> One or more video cables is loose or disconnected. No power to Remote or Local Units. Video Cable was not attached when CPU was booted. CAT5 cable is not connected. 	<ul style="list-style-type: none"> Check all video cable connections Make sure power LEDs are illuminated for Local and Remote (green LEDs). If not, see solutions for first two problems above. With all the cables properly connected, reboot the CPU. Check cable connections. Make sure they are snapped-in properly and completely and reboot.

Problem	Cause	Solution
Video Picture is not sharp or is smeared	<ul style="list-style-type: none"> All Video Cables are not firmly seated. CAT5 cable is too long. The CAT5 cable is not properly connected. Video not adjusted 	<ul style="list-style-type: none"> Check all connections. Make sure all cables are fully seated. Verify length is within specified limits-500'. Check cable connections. Make sure they are snapped-in properly and completely. Check cable connections and power cycle.
The picture on the monitor is black and white, rather than color	The video cable was not attached to the CPU when it was booted.	With the cables all properly connected, reboot the CPU.
A constant vertical wobble appears down the screen	CAT5 cable is too close to a strong power source.	Reroute CAT5 cable if possible.
Monitor sometimes loses sync, causing it to go blank for a second or two	<ul style="list-style-type: none"> Electrical power system is very noisy, particularly the ground. The CAT5 cable is not properly connected. 	<ul style="list-style-type: none"> Make sure the interconnection cable is not near any power lines. Check cable connections. Make sure they are snapped-in properly and completely.
Image is not displayed properly, lacks definition	Signal is being skewed by the CAT5 cable and not being received correctly by the monitor .	<ul style="list-style-type: none"> Check the user's manual for the monitor, projector, or display equipment for an "automatic adjustment" or "auto-configure". This is most common to LCD type monitors.
No audio	<ul style="list-style-type: none"> Audio cable is not properly plugged in Speakers are not plugged in CAT5 cable is not properly connected 	<ul style="list-style-type: none"> Check all cable connections Verify speakers are connected and powered Check CAT5 cable connections

WARRANTY INFORMATION

The warranty period on this product (parts and labor) is one (1) year from the date of purchase. Please contact Network Technologies Inc at **(800) 742-8324** (800-RGB-TECH) or **(330) 562-7070** or visit our website at <http://www.networktechinc.com> for information regarding repairs and/or returns. A return authorization number is required for all repairs/returns.

Free Manuals Download Website

<http://myh66.com>

<http://usermanuals.us>

<http://www.somanuals.com>

<http://www.4manuals.cc>

<http://www.manual-lib.com>

<http://www.404manual.com>

<http://www.luxmanual.com>

<http://aubethermostatmanual.com>

Golf course search by state

<http://golfingnear.com>

Email search by domain

<http://emailbydomain.com>

Auto manuals search

<http://auto.somanuals.com>

TV manuals search

<http://tv.somanuals.com>