



BigVizion
1080p HIGH DEFINITION DISPLAY

Installation Guide
HDBV3100, HDBV3090, HDBV3080

High-Definition Lifestyle

BigVizion In-Wall Rear Projection Display

Optoma's BigVizion is an in-wall modular rear projection display consisting of a framing system, system control components, a mirror, screen frame assembly and DLP® light engine.

The BigVizion is a modular designed system and offers front access to all components through a movable front screen frame assembly.

HDBV3100, HDBV3090, HDBV3080

The BigVizion is available in three models: HDBV3100 (100"), HDBV3090 (90") and HDBV3080 (80"). These models differ only by size. The installation details with front and side views are included in the master frame installation section of this guide.

About this Manual

This manual exclusively describes the set-up and use of Optoma's in-wall rear projection displays.

This manual covers the installation steps in the following order:

- Creating wall openings for BigVizion 100", 90", 80"
- Unpacking and identifying all system parts and components
- Preparing the BigVizion for installation
- Installing the BigVizion frame components
- Configuring all system components
- Adjustment, alignment, and operation
- Servicing

FCC WARNING

This equipment has been tested and found to comply with the limits for a “Class B” digital device, pursuant to Part 15 of the FCC rules. These limits are designed to provide reasonable protection against harmful interference in a residential installation. This equipment generates, uses, and can radiate radio frequency energy, and if not installed and used in accordance with the instructions, may cause harmful interference to radio communications. However, there is no guarantee that interference will not occur in a particular installation. If this equipment does cause harmful interference to radio or television reception (this can be determined by turning the equipment off and on), the user is encouraged to try to correct the interference by one or more of the following measures:

- Reorient or relocate the receiving antenna
- Increase the separation between the equipment and the receiver
- Connect the equipment to an outlet on a circuit that the receiver is not connected to
- Consult the dealer or an experienced radio/TV technician for help

Any changes or modifications to this “Class B” digital device that has not been expressly approved by Optoma Technology, Inc. will void the user’s authority to operate the equipment.

TRADEMARK NOTICE

The BigVizion™ is a trademark of Optoma Technology, Inc. All other trademarks and registered trademarks are the property of their respective owners.

COPYRIGHT NOTICE

© Copyright 2006 Optoma Technology, Inc.

This document contains proprietary information protected by copyright. All rights are reserved. No part of this manual may be reproduced by any mechanical, electronic, or other means, in any form, without prior written permission of the manufacturer.

Installation Preparation

WARNING:

All installations must be performed in accordance with standard utility practice; The National Electric Code, The National Electric Safety Code, The Local Electric Code, and any local city ordinances that may apply to building construction and/or modification to residential structures.

In the event of a conflict regarding any standards governing the installation/construction of the BigVizion system, or any component thereof, the strongest standard shall apply.



MIRROR HANDLING

The mirror is extremely fragile. Exercise extreme caution when moving.

Mirror weight is ~150 lbs.



TYPICAL TOOLS FOR INSTALL

Installation requires:

- 1) Power drill
- 2) 1/2" open-ended wrench and socket set
- 3) Level
- 4) Flathead and Philips head screwdriver
- 5) Utility knife

Contents

Section I: Preparation for the Installation

- 1) Position and Placement of the BigVizion
- 2) Preparing the Wall
- 3) Shipment of Box 1 (Master Outer Frame) to Job Site
- 4) Master Outer Frame Assembly
- 5) Installation of the Master Outer Frame

Section II: Installation of the Frame Components

- 1) Shipment of the Internal Frame Components to the Job Site
- 2) Unpacking the Mirror
- 3) Installation of the Mirror
- 4) Unpacking of the Base Unit Components
- 5) Assembly of the Base Unit
- 6) Installation of the Base Unit
- 7) Installation of the Screen Frame
- 8) Installation of the Wood Bezel

Section III: Alignment of the Light Engine

- 1) Alignment Platform Adjustment Procedure

Appendix A: Cable Wiring/Connections

- 1) Cables
- 2) Connectors
- 3) Instructions

Appendix B: Discrete IR/RS-232C Codes

- 1) HD3000 RS-232C Protocol Function List

Appendix C: Exploded View of the Product

Section I: Preparation for the Installation

1. Position and Placement of the BigVizion

Wall selection is crucial in the BigVizion installation for producing the desired image quality. The BigVizion may be installed during new home construction or aftermarket remodels. New home construction lends itself to better placement, since the BigVizion could be implemented during the design phase. Aftermarket installation requires more detailed thought for its placement. Consider the following guidelines:

- 1) Select a wall position that does not allow any direct sunlight or lighting
- 2) Select a wall placement that allows side or rear access for installation
- 3) Adhere to the minimum wall depths required for installation

2. Preparing the Wall

For new home construction, the roughing stage to the final installation may take several months. The BigVizion packaging has been designed for the master frame (Outer Master Frame) to be installed during the roughing stage. Follow the listed steps for installation:

Wall Preparation:

Step 1:

The location of the installation will be determined by environmental factors such as wall depth, lighting and ideal viewing heights.

The ideal vertical placement of the BigVizion in the wall opening created, as measured from the floor to the sill (bottom of the screen) for seated viewing, is as follows:

Model	Screen Size	Height from seated position
BVHD3100	100"	~ 20.5"
BVHD3090	90"	~ 23"
BVHD3080	80"	~ 25.5"

NOTE: The above are recommendations, the final decision will be determined by the installation professional based on room and environmental factors.

Step 2:

Cut a rough opening through the wall at the correct height, so when finished with the standard 2" x 4" wood framing, the opening corresponds to the following dimensions:

- BVHD3100 (100"), the rough wall opening must measure at least: 91-11/16" W x 54-13/16" H.
100" BigVizion Wall Opening Diagram. (Figure 1-1)
- BVHD3090 (90"), the rough wall opening must measure at least: 83" W x 50" H.
90" BigVizion Wall Opening Diagram. (Figure 1-2)
- BVHD3080 (80"), the rough wall opening must measure at least: 74-1/4" W x 45" H.
80" BigVizion Wall Opening Diagram. (Figure 1-3)

NOTE: The above listed dimensions are suggested minimums, and can be made slightly larger to accommodate shim material. *Wall must be level on all sides. Check with plumb lines and level.*

IMPORTANT!

See the next three diagrams of the 100"/90"/80" for detailed dimensions of required wall opening.

Figure 1-1: 100" BigVizion Wall Opening

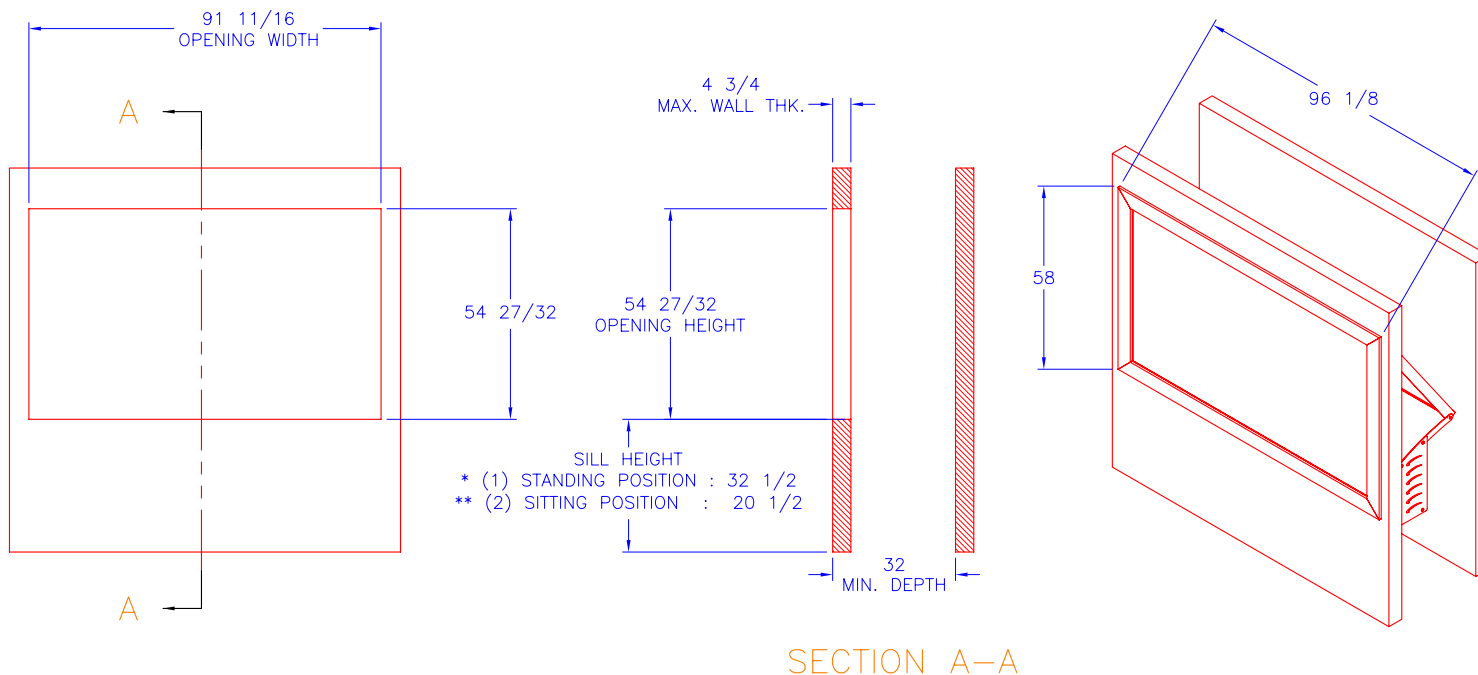

- * STANDING POSITION PREDICATED ON 60" CENTER SCREEN HEIGHT
- ** SITTING POSITION PREDICATED ON 48" CENTER SCREEN HEIGHT

Figure 1-2: 90" BigVizion Wall Opening

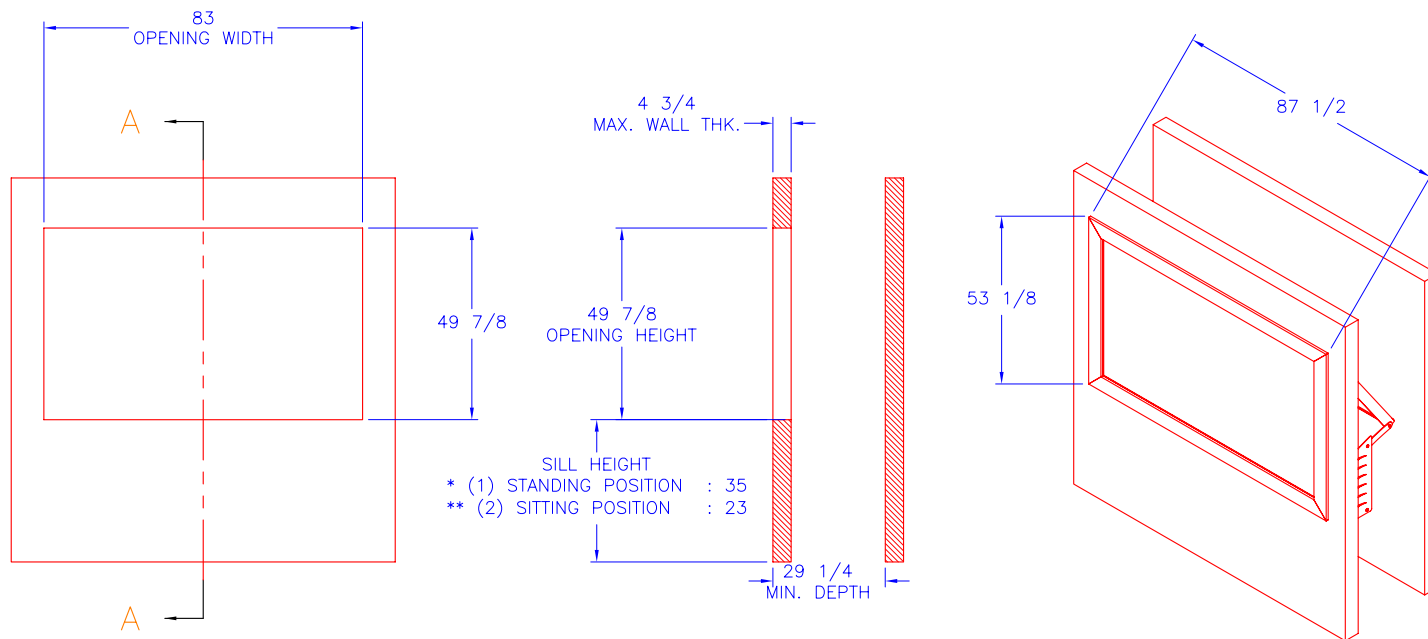

SECTION A-A

- * STANDING POSITION PREDICATED ON 60" CENTER SCREEN HEIGHT
- ** SITTING POSITION PREDICATED ON 48" CENTER SCREEN HEIGHT

Figure 1-3: 80" BigVizion Wall Opening

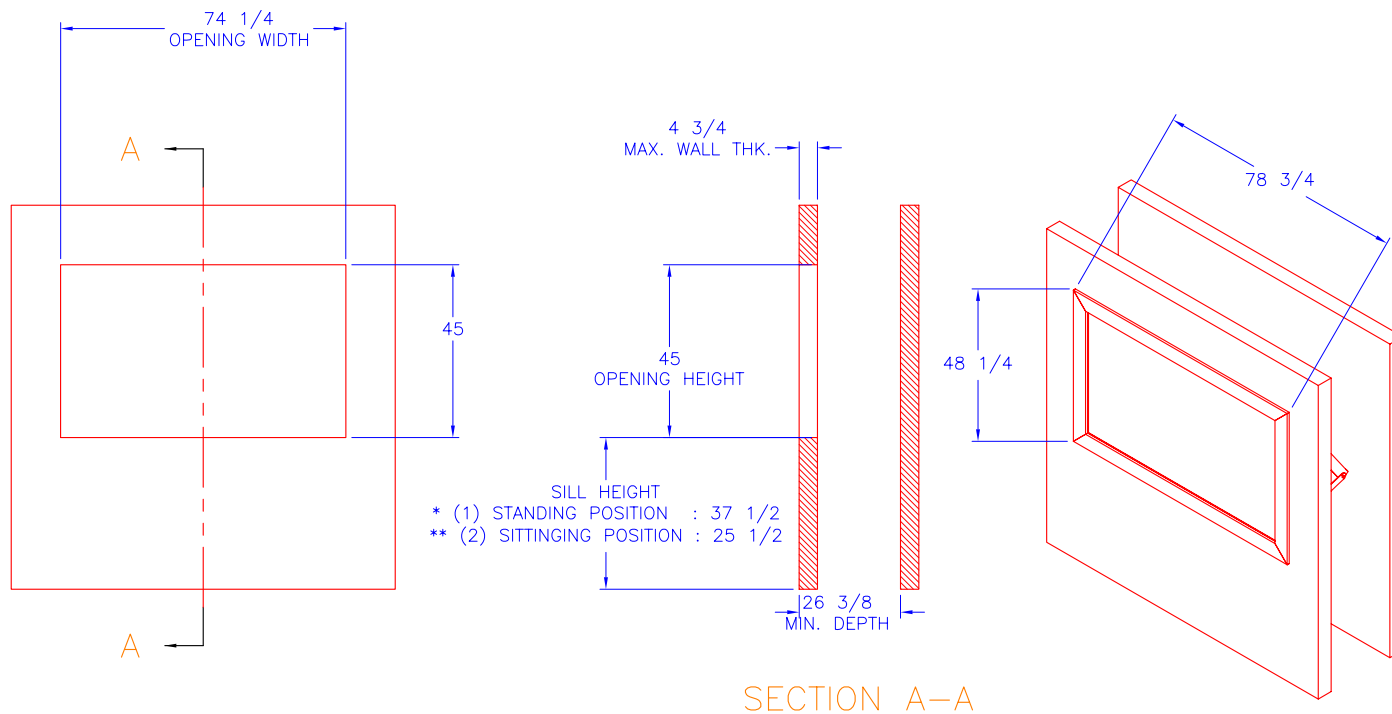

- * STANDING POSITION PREDICATED ON 60" CENTER SCREEN HEIGHT
- ** SITTING POSITION PREDICATED ON 48" CENTER SCREEN HEIGHT

3. Shipment of Box 1 (Master Outer Frame)

The master outer frame is located in a knock down box as part of the master BigVizion shipment module. Unscrew the box from the shipment module and bring to the installation site during the roughing stage of the construction.

Step 1:

Carefully unpack the master outer frame; two vertical and two horizontal pieces.

See Figure 1-4: Box #1 Detail

Notice each piece is marked left, right, top and bottom.

Step 2:

Set aside the hardware pack:

- Eight #10-32 screws and washers
- Twenty-six #8 x 2" Philips dry wall screws

Step 3:

Carefully lay the pieces of the master outer frame on a smooth flat surface and observe the orientation markings.

IMPORTANT! Exercise caution, since the frame is flexible.

See Figure 1-4: Box #1 Detail

Figure 1-4: Box #1 Detail

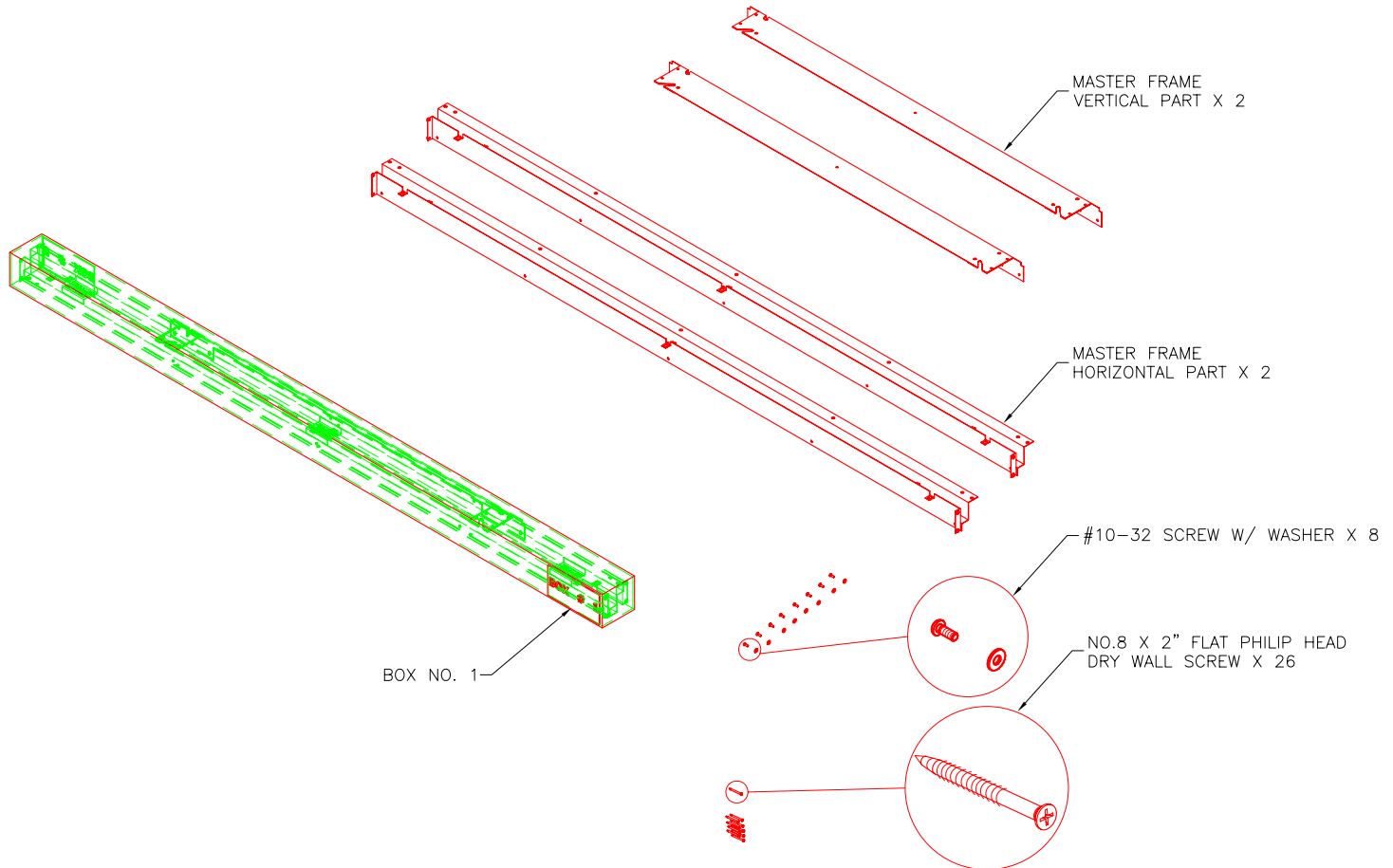

4. Assembly of the Master Outer Frame

Step 1:

Locate the eight #10-32 screws with washers.

Step 2:

Insert two #10-32 screws with washers on each corner to assemble frames; left, right, top and bottom.

IMPORTANT! See Figure 1-5: Installation of the Master Frame Diagram.

Figure 1-5: Installation of the Master Frame

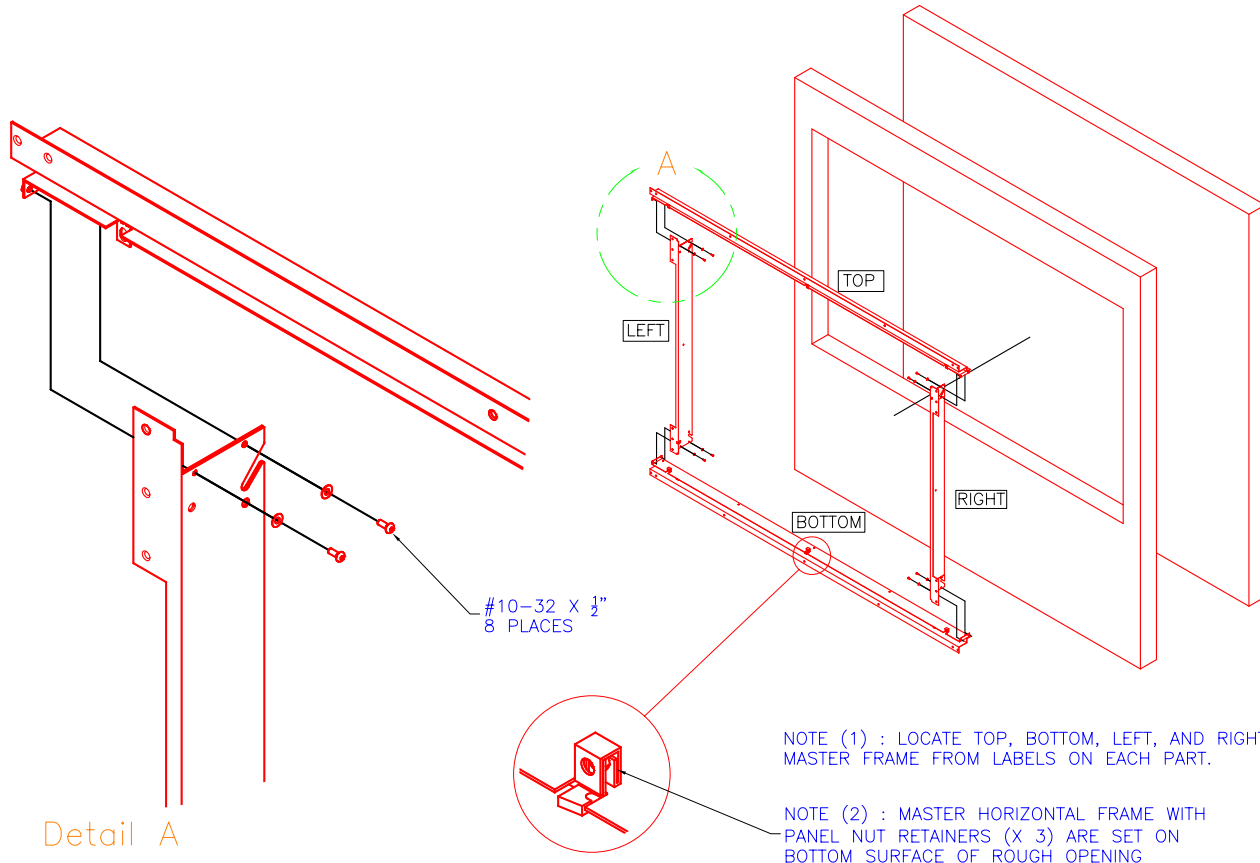

Installation of the Master Outer Frame into the Wall Opening

Step 1:

With a minimum of two people, carefully raise the master outer frame from the smooth surface while supporting the frame on the left and right side.

IMPORTANT! Exercise caution when raising the frame.

Step 2:

Position the frame in the wall opening.

Step 3:

Make certain that the frame is positioned, squared and flushed in the wall opening.

Step 4:

Insert the twenty-six #8 x 2" dry wall screws through the holes in the frame and the 2" x 4" wood stud behind the wall.

IMPORTANT! Make certain the frame is flush and square, using plumb lines and carpenters square.

If the frame is not square, the image from projector will not align correctly.

THIS IS THE MOST CRUCIAL PART OF THE INSTALLATION!

See Figure 1-6: Installation of the Master Frame into the Wall Opening

Figure 1-6: Installation of the Master Frame into the Wall Opening

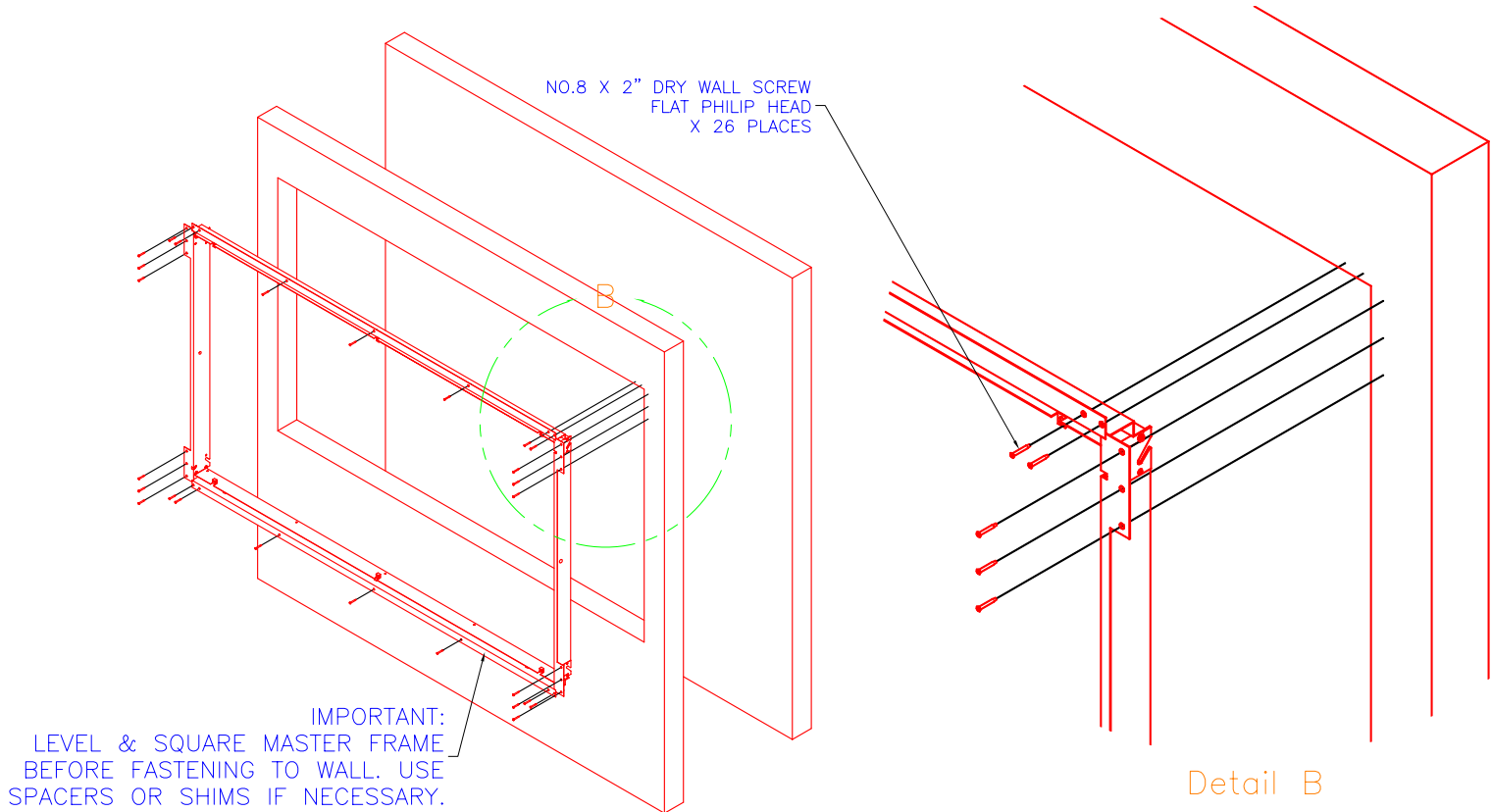

Section II: Installation of the Frame Components

1. Shipment of the Internal Frame Components to the Job Site

Once the outer master frame has been installed, have the remainder of the framing components available at the installation site. This includes the internal framing components and all electronics.

2. Unpacking the Mirror

Step 1:

Make certain that there are at least three people available for the unpacking and installation of the mirror.

IMPORTANT! The mirror is heavy ~150lbs.

Step 2:

Remove the front of the crate by removing the screws with the red washers only.

Step 3:

Remove the two wood braces on the left and right side of the mirror that holds the mirror in the crate. The braces are held in place by two Philips screws on both sides of the mirror.

Step 4:

Carefully remove the mirror from the crate by lifting it slightly up and pulling it straight out.

Step 5:

Carefully set the mirror aside on a smooth surface.

See Figure 2-1: Exploded View of the Mirror and the Frame

Figure 2-1: Exploded View of the Mirror and the Frame

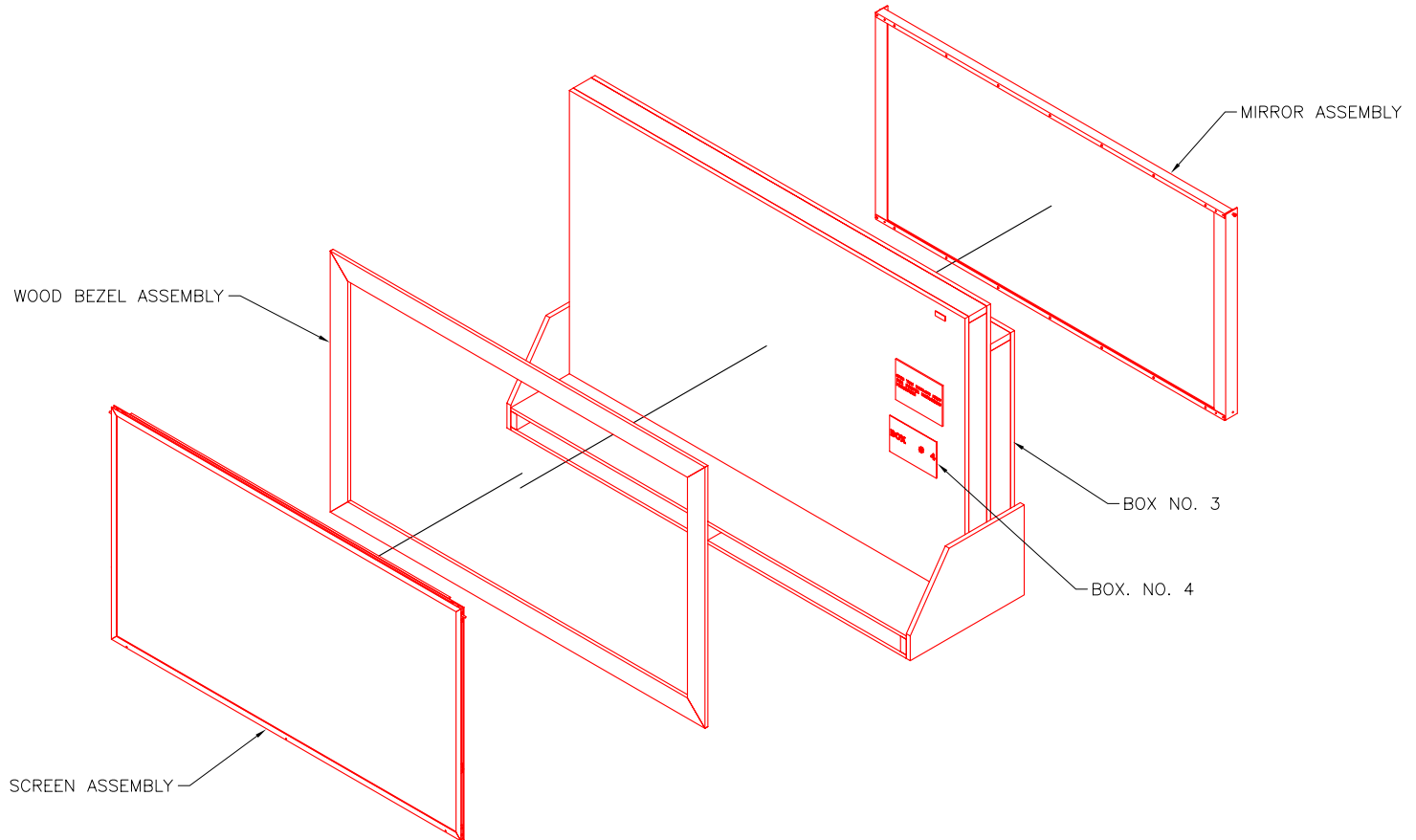

3. Installation of the Mirror

To install the mirror, have two people lift the mirror, as well as a safety person to guide the mirror. Carefully move the mirror through either a side opening or a rear opening in the wall behind the master outer frame. Slide the shoulder bolt that is on the top left side of the mirror through the slot on the left top of master frame, and repeat this with the right side.

See Figure 2-2: Installation of the Mirror Assembly.

Warning! Since the mirror has no support, someone should always hold the mirror in place during installation. Allow the mirror to gently come towards the front of the wall and remain in a vertical position for the next installation step.

Figure 2-2: Installation of the Mirror Assembly.

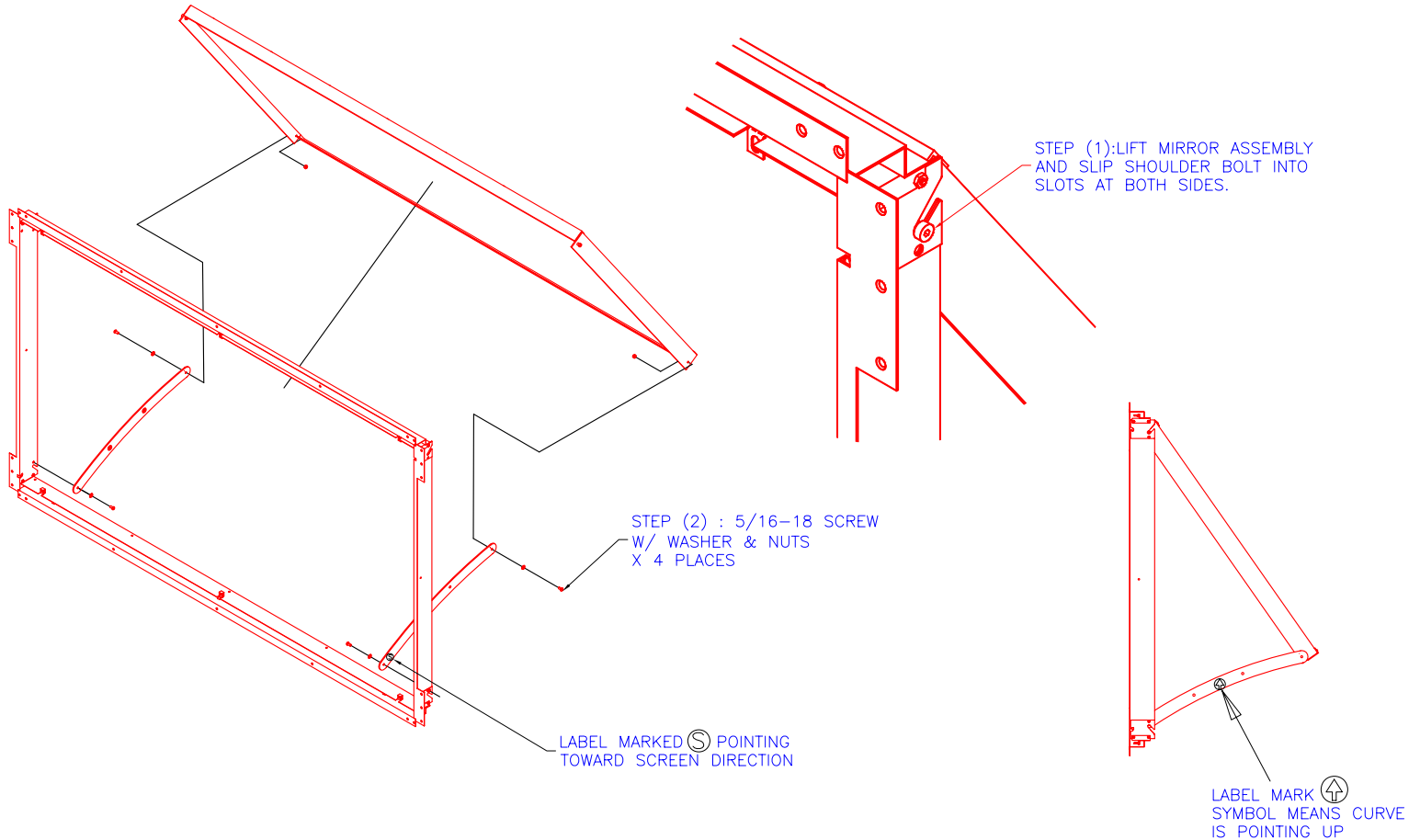

4. Unpacking of Base Unit and Components

Step 1:

Locate Box 2. **Refer to Figure 2-3: The Unpacking Diagram.**

Step 2:

Remove the screws with red washers, and remove the lid on the crate.

Box 2 contains the following:

- Two mirror stay arms
- Two base hangers
- Two stabilizer arms
- One projector and component base
- One projector light hood
- Two gage alignment blocks
- Twelve 5/16"-18 x 3/4" bolts and nuts

See Figure 2-4: Box 2 Detail

Step 3:

With two people, carefully remove the base unit.

Note that the two wooden blocks are used to prevent the base unit from moving during shipment.

Step 4:

Remove the screws with red washers that hold the wooden blocks in place.

Step 5:

Lift the base unit out of the crate and set it aside on a smooth surface.

Step 6:

Organize the mirror stay arms, base hangers, stabilizer arms, gage blocks and hardware.

Step 7:

Locate the two mirror stay arms. Note the orientation arrow for this end up, as well as the one end marked **S** to denote pointing towards the screen or front of the wall.

Step 8:

Working from inside the wall space, attach the front of the mirror stay arm (S) towards the screen/wall to the bottom portion of the master outer frame. Use two 5/16-18 x 3/4" screws for the left stay arm and the right stay arm.

Step 9:

The curve side of mirror stay arm points up. Observe the arrow on both stay arms.

Step 10:

Refer back to Figure 1-2.

IMPORTANT! Make certain the mirror stay arms are attached with the (S) pointing towards the screen, or the front of the wall, oriented from inside the wall space.

Step 11:

Carefully raise the mirror towards the back of the wall. Using two 5/16-18 x 3/4" screws and nuts, attach the rear mirror stay arms to the mirror.

IMPORTANT! Have three people available to hold the mirror in position and to attach the mirror stay arms.

Refer back to Figure 1-2.

Figure 2-3: The Unpacking Diagram

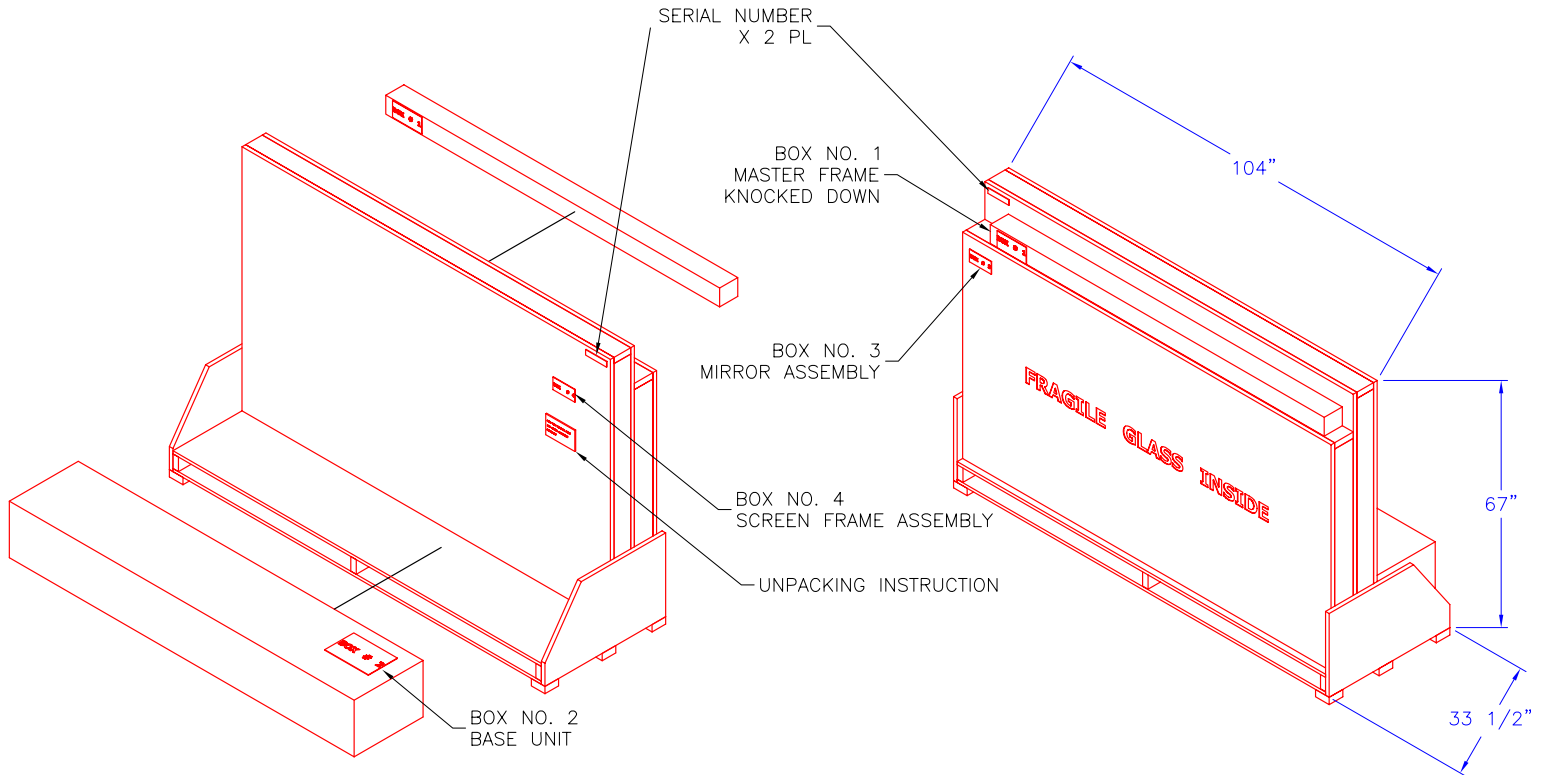



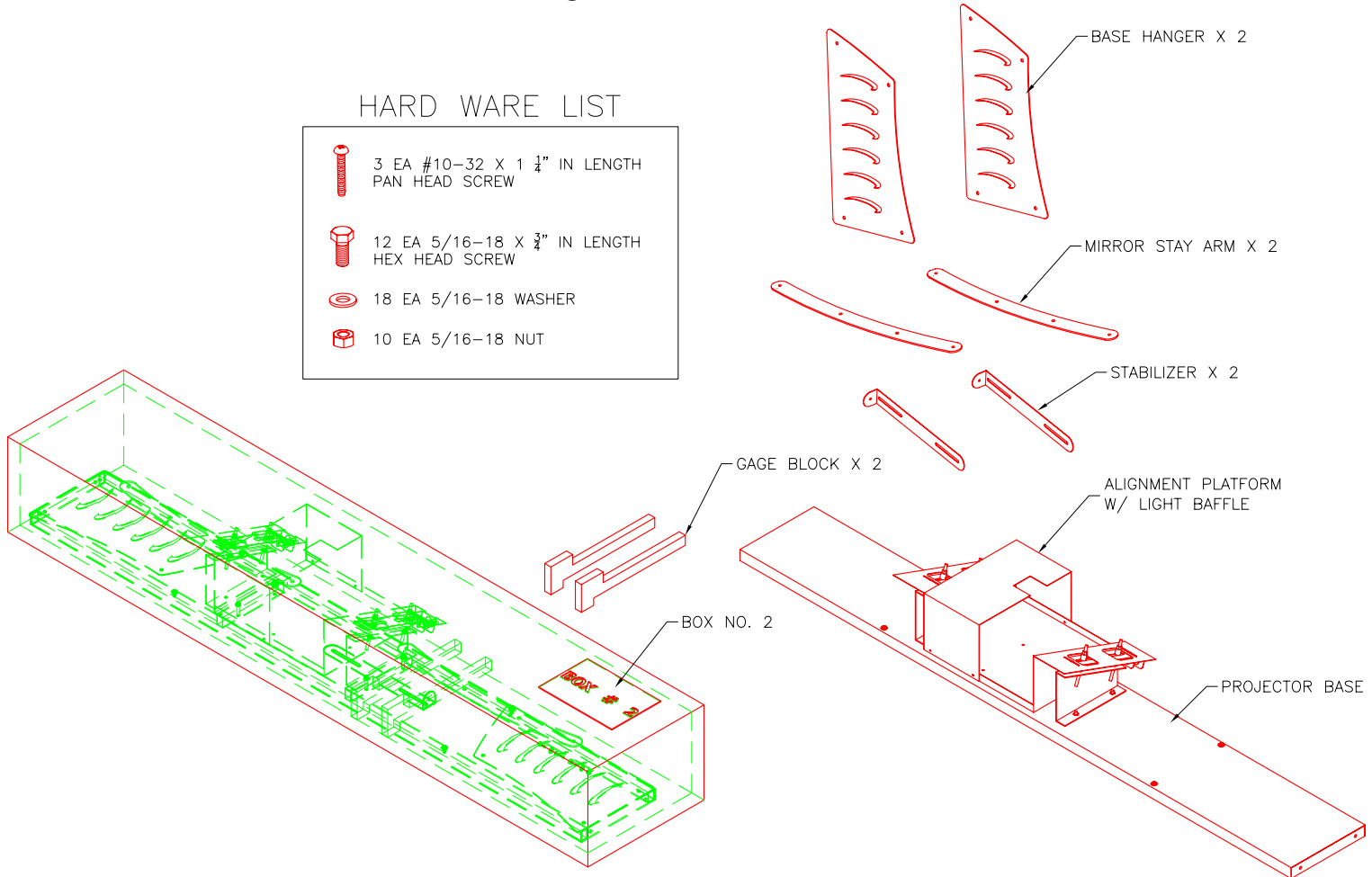

Figure 2-4: Box 2 Detail

HARD WARE LIST

	3 EA #10-32 X 1 1/4" IN LENGTH PAN HEAD SCREW
	12 EA 5/16-18 X 3/4" IN LENGTH HEX HEAD SCREW
	18 EA 5/16-18 WASHER
	10 EA 5/16-18 NUT



5. Assembly of the Base Unit

Step 1:

Locate the base unit and the two base hangers that were set aside. (Refer back to **Figure 2-4: Box 2 Detail.**)

Step 2:

Carefully lift the bottom of the base unit by lifting the left and right side. Attach the base hangers as shown in **Figure 2-5: Installation of the Projector Base.**

(Note the orientation of the base hangers; (S) for towards the front/screen and (M) towards the back/mirror.)

Step 3:

With at least two people, lift the base unit, position it in to the wall below the mirror and align the base hangers directly under the mirror stay arms for later attachment.

6. Installation of the Base Unit

Step 1:

Working from the front of the wall opening with a minimum of two people, carefully raise the base unit.

Step 2:

Position the base hangers to the outside of the mirror stay arms.

Step 3:

Insert four 5/16-18 x 3/4" screws with washers through the two middle holes on the mirror stay arms.
Note: Washers need to be inserted on both the inside and outside of the mirror stay arms.

Step 4:

Insert and tighten the nuts on the 5/16-18 x 3/4" screws.

See Figure 2-5: Installation of the Projector Base.

Figure 2-5: Installation of the Projector Base.

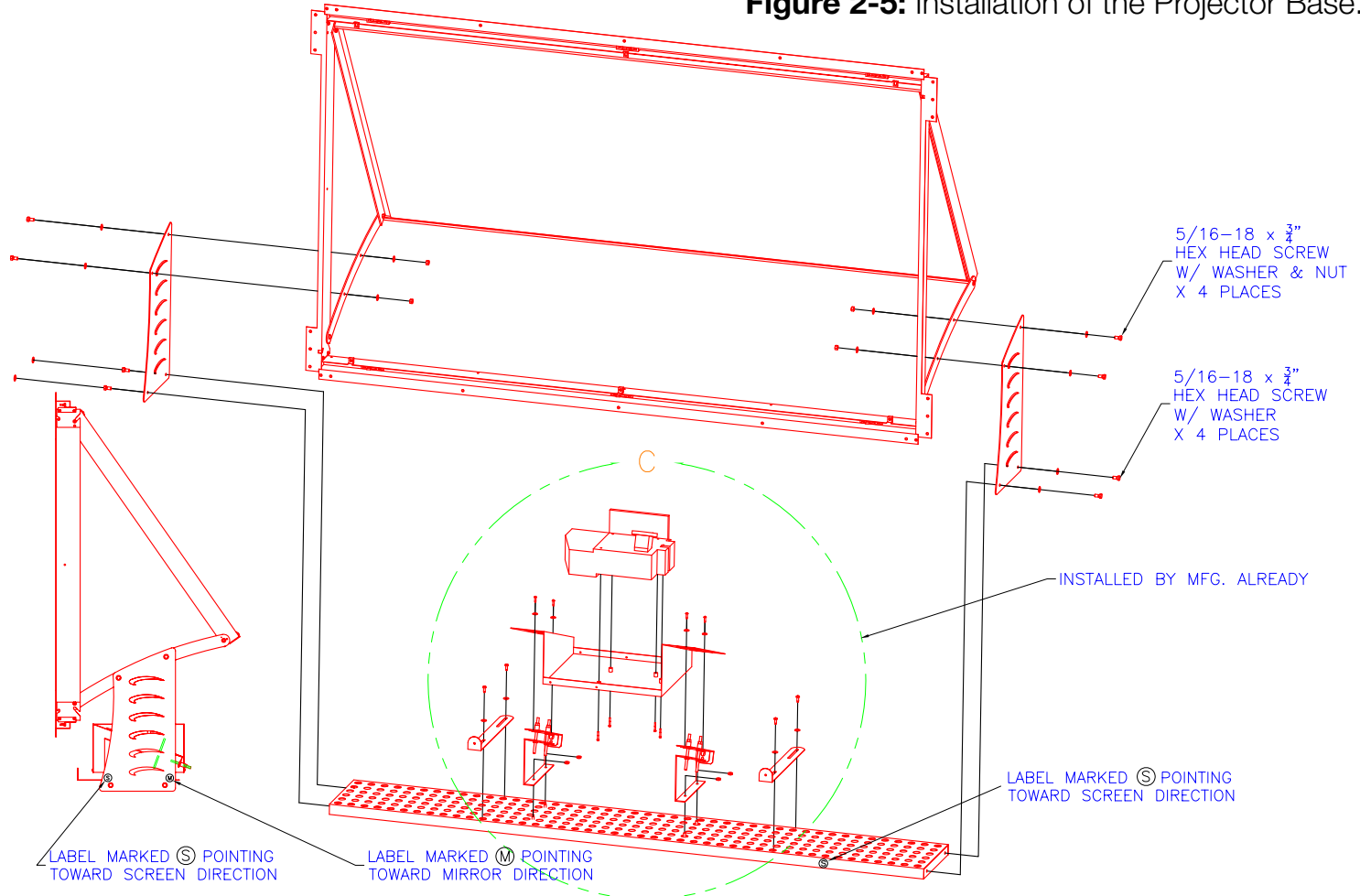

7. Installation of the Screen Frame

Step 1:

Locate box 3 that the mirror was removed from. (Refer back to the master crate.)

Step 2:

Remove the two side panels that attach box 3 to the bottom of the crate. (Necessary to access box 4)

Step 3:

On the left and right side panel, only remove the screws with red washers that secures box 3 to the master crate.

Step 4:

Carefully remove box 3 from the crate and set it aside; it is no longer needed.

Step 5:

Remove the lid on box 4 by removing all the screws with red washers.

(Referring to Figure 2-3: The Unpacking Diagram.)

Step 6:

Box 4 contains both the screen frame assembly and the wood bezel.

Step 7:

Carefully separate the screen frame assembly from the bezel and move it towards the front of the master outer frame.

Step 8:

Carefully unwrap the protective paper around the screen frame.

Step 9:

The screen frame has two sides. The back side has ridges and circles; while the front side is smooth with a plastic wrap.

Step 10:

Notice that the screen frame has two pins on each side; the left and right.

Step 11:

If you are facing the front of the outer master frame, it has a hole on the top left side and a slot on the top right side.

Step 12:

With two people, lift the screen frame up with the glossy side facing out. Align the pin on the top left side first, and slide in. Match it with the hole on the left side of the master outer frame. The third person will help guide the pin alignment. With the other pin, match the right side of the screen frame with the slot on the right side of the master outer frame.

See Figure 2-6: Installation of the Screen.

Figure 2-6: Installation of the Screen

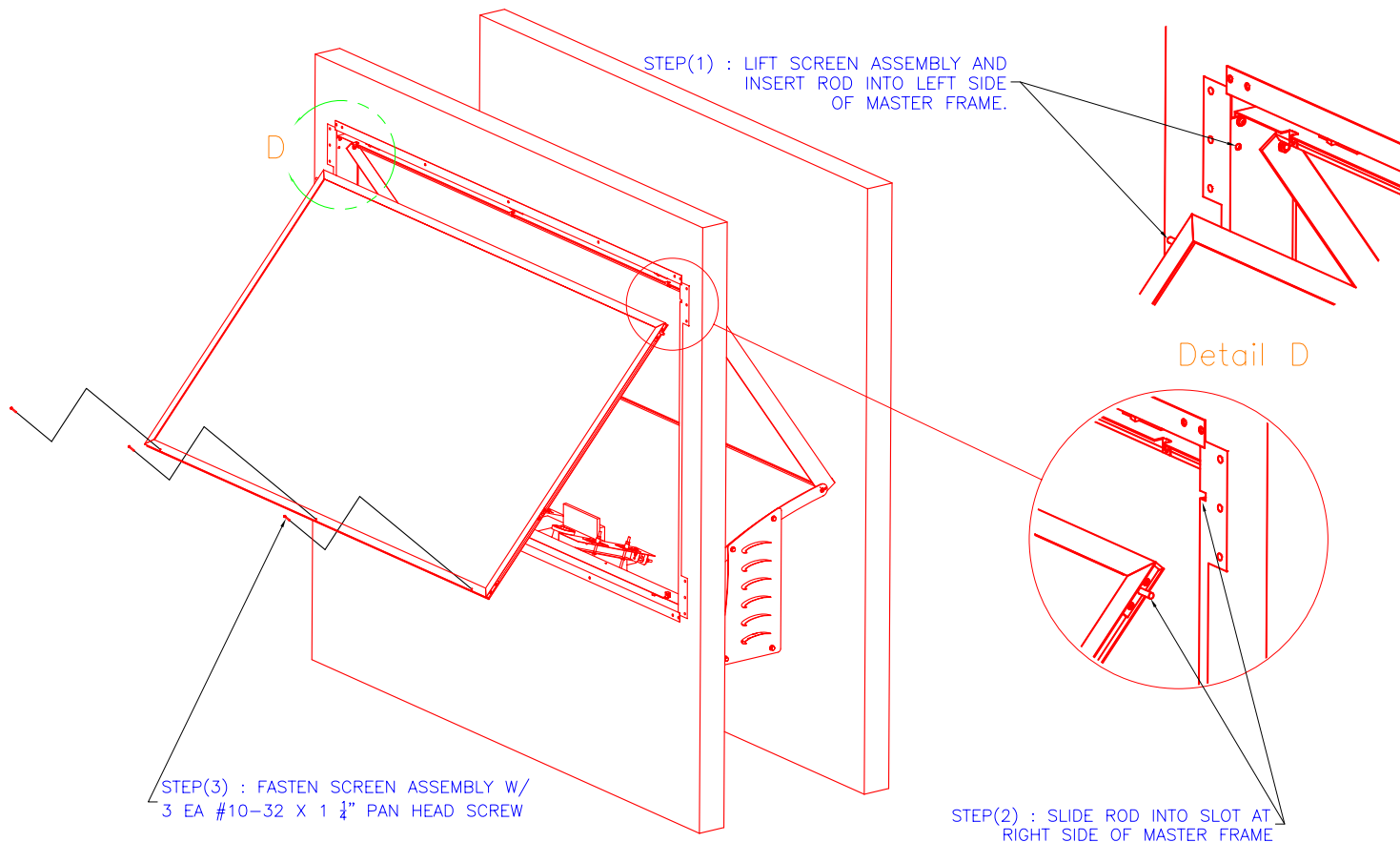

8. Installation of the Wood Bezel

Locate the wood bezel that was set aside during the screen frame assembly. Use the following steps to install the bezel.

Step 1:

With two people, carefully orient the wood bezel vertically.

Step 2:

Align the six grabber catches, the female part of the bezel clip and the male part of the main frame.

Step 3:

Position the bezel so the bottom arrows on the bezel align with the bottom arrows on the master outer frame. Push in the bottom of the bezel until the catches lock. Once the bottom of the bezel is aligned and locked, push the top of the bezel until it locks.

See Figure 2-7: Installation of the Wood Bezel.

Figure 2-7: Installation of the Wood Bezel

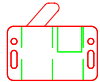

OPENED
CONDITION
(Fig: 7-1)

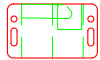

CLOSED
CONDITION
(Fig: 7-2)

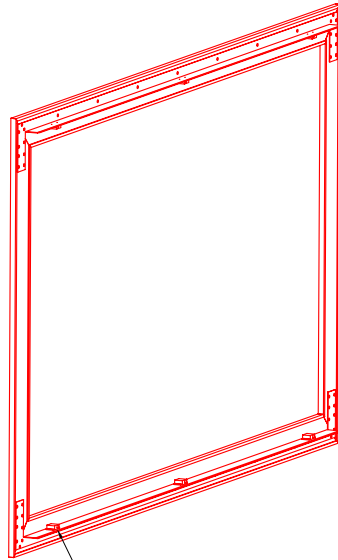

STEP (1): CHECK THAT THE 6
INTERLOCK FEMALE PARTS
ON BEZEL CLIP ARE ALL
IN OPEN POSITION (Fig: 7-1)

IF THE FEMALE PARTS ARE IN
CLOSED POSITION (Fig: 7-2)
USE SCREW DRIVER TO PUSH
TO OPEN POSITION.

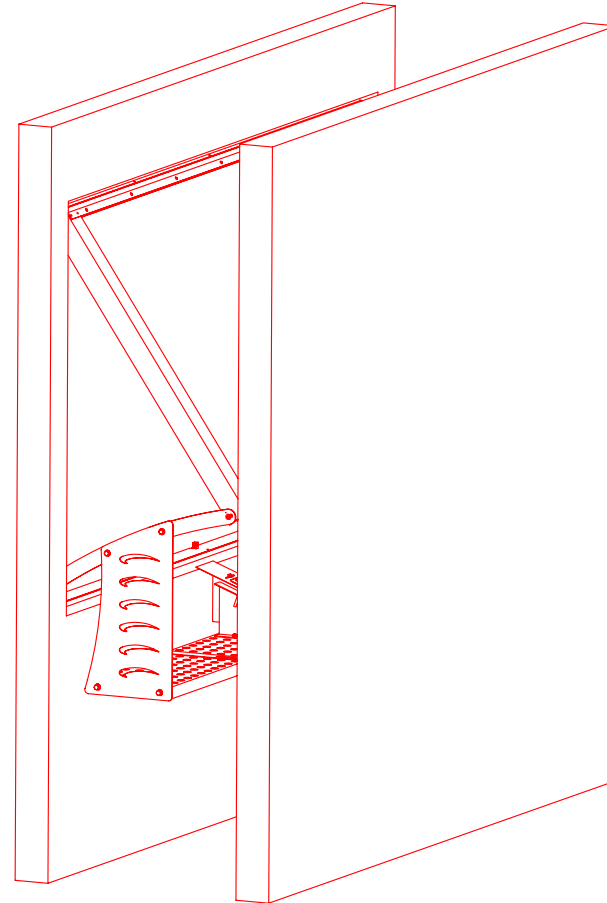

Section III: Alignment of the Light Engine

ALIGNMENT PLATFORM ADJUSTMENT PROCEDURE

Use the Video Essentials or Avia Test DVD for alignment patterns.

Step 1:

Using two gage blocks for initial positioning, adjust the alignment platform (AP) until the bottom of AP surface contacts the gage blocks and the rear edge of both the AP and the projection base (PB) contacts the corners of the gage blocks.

See Figure 3-1: Setting the Gage on “0” Position.

Step 2:

Remove the gage blocks and fine tune the image per **Figures 3-2, 3-3, 3-4, 3-5, 3-6 and 3-7.**

Figure 3-1: Setting the Gage on “0” Position

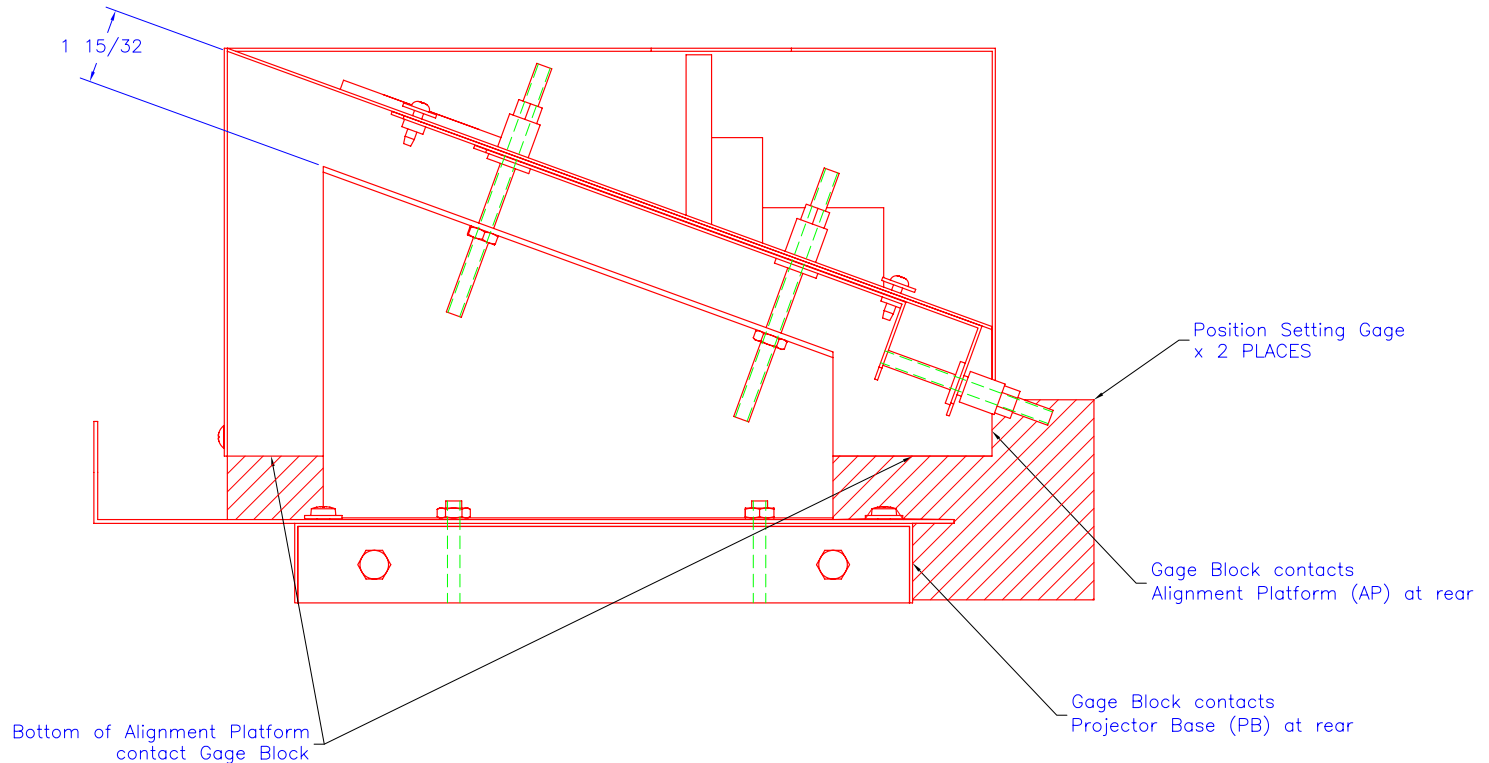

Problem:
(Vertical Keystone)

Solution:
Turn knobs #1 & 4 together in the same direction.

Figure 3-2: Vertical Keystone Adjustment

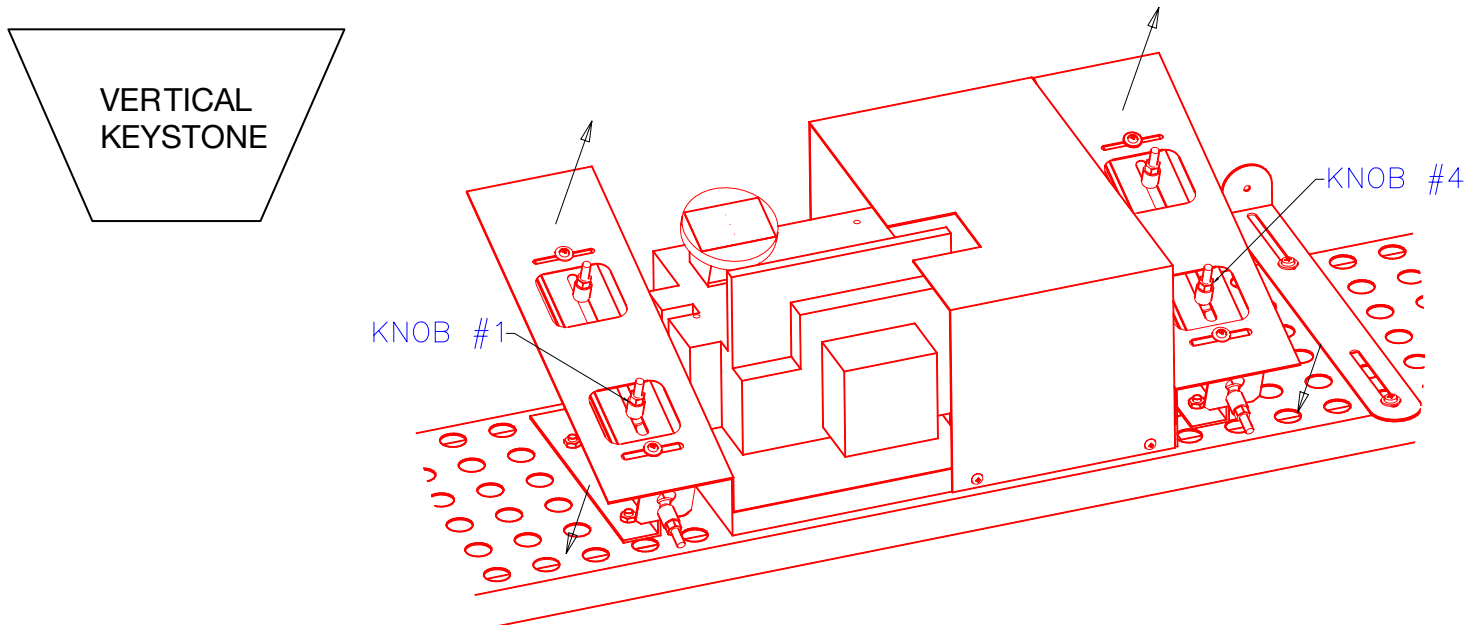

Problem:
(Horizontal Keystone)

Solution:
Turn knobs #3 & 4 together in the same direction.

Figure 3-3: Horizontal Keystone Adjustment

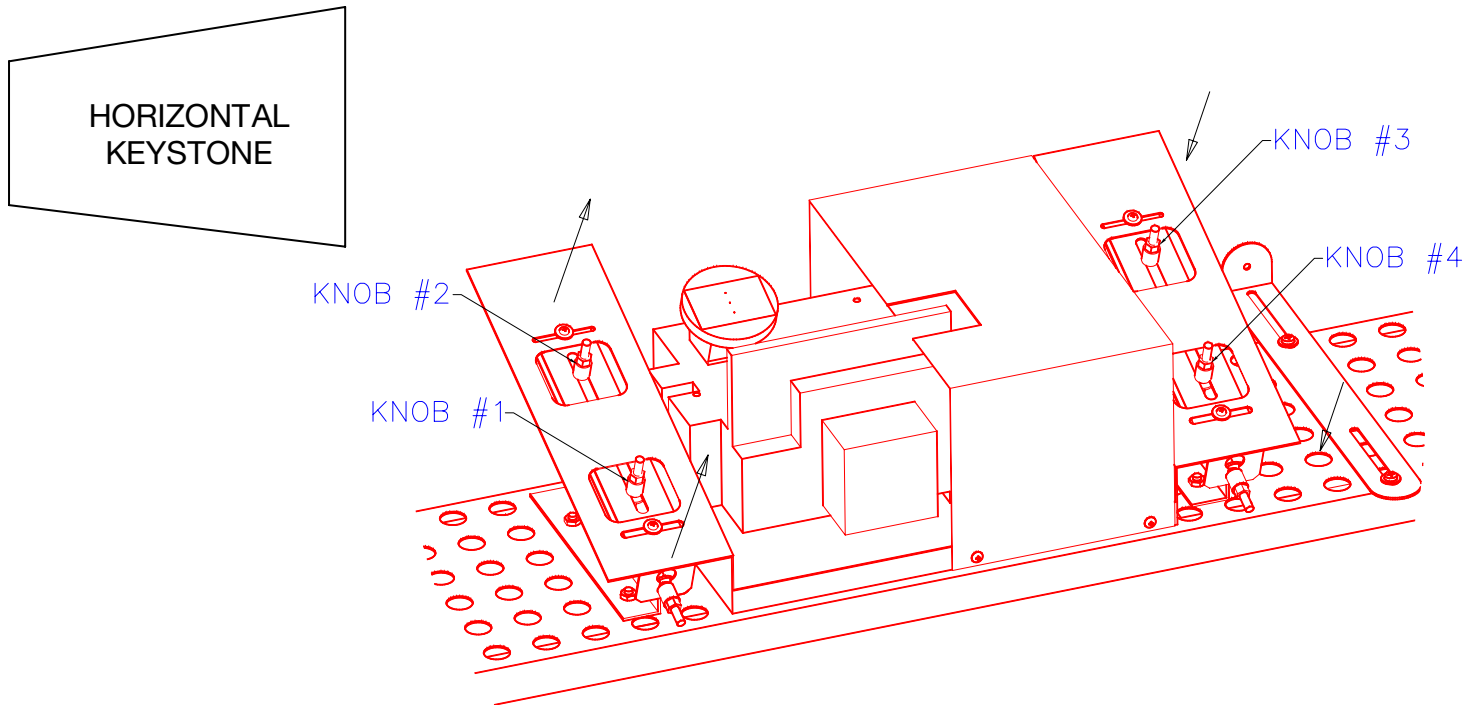

Problem:
(Skewed Image)

Solution:
Turn knobs #5 & 6 in opposite directions.

Figure 3-4: Skewed Image Adjustment

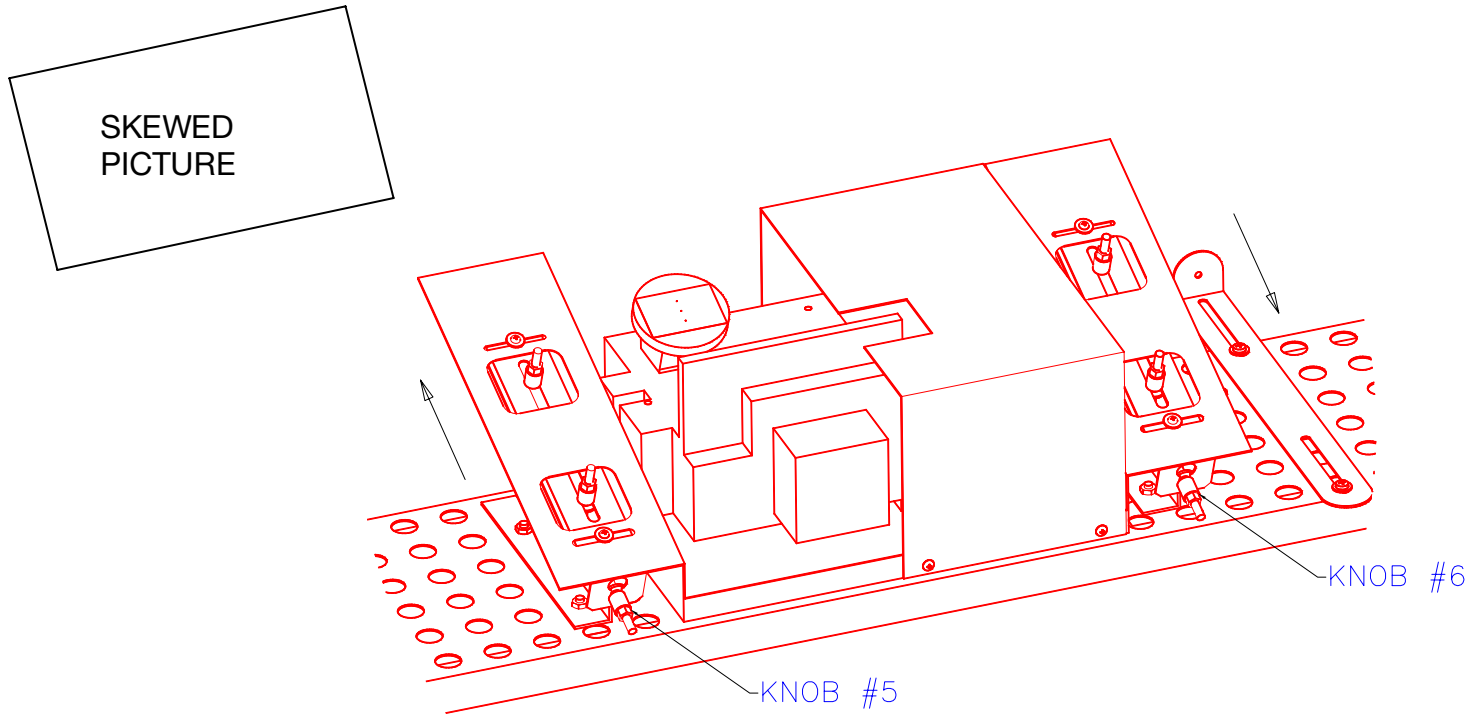

Problem:
(Image Shift Vertically)

Solution:
Turn knobs #5 & 6 in the same direction.

Figure 3-5: Image Shift Vertically Adjustment

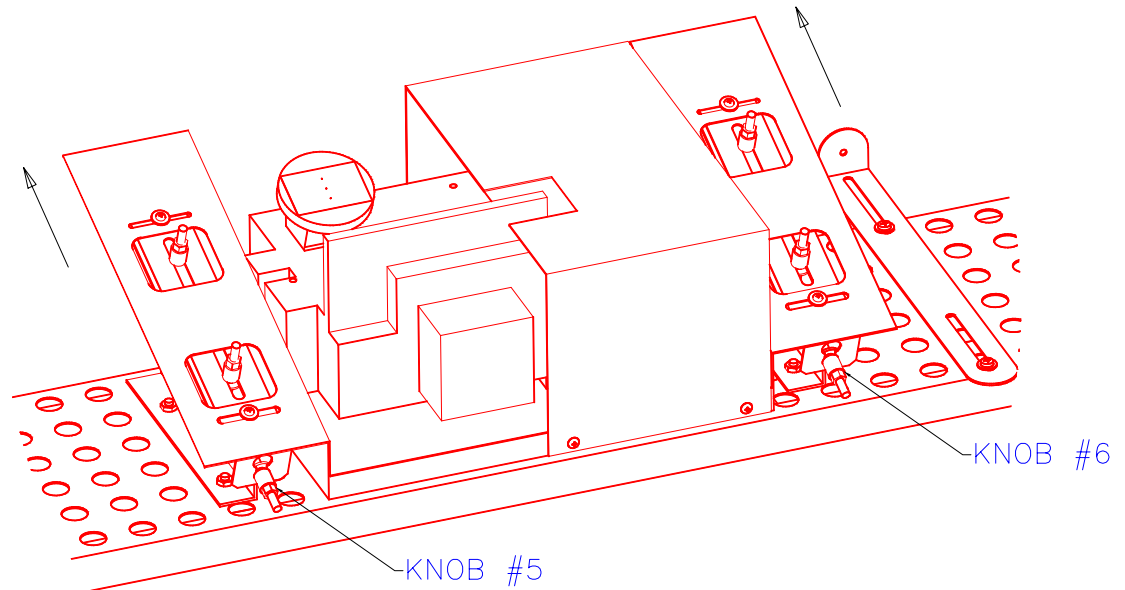

Problem:
(Image Shift Horizontally)

Solution:
Loosen the four Philips head screws just enough to manually shift AP to the left or right and then tighten the screws.

Figure 3-6: Image Shift Horizontally Adjustment

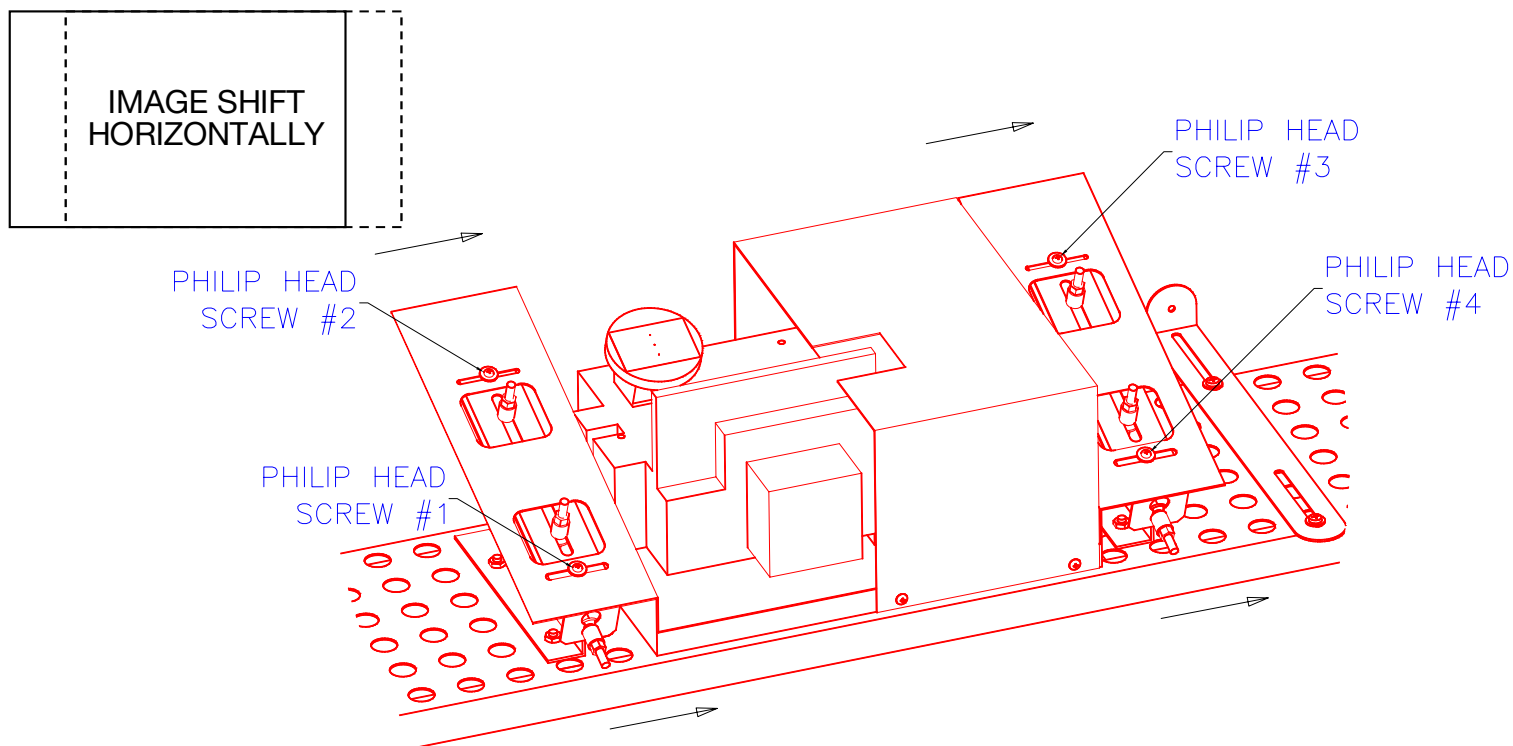

Problem:
(Image Sizing)

Solution:
Turn knobs #1, 2, 3 & 4 in the same direction.

Figure 3-7: Image Sizing Adjustment

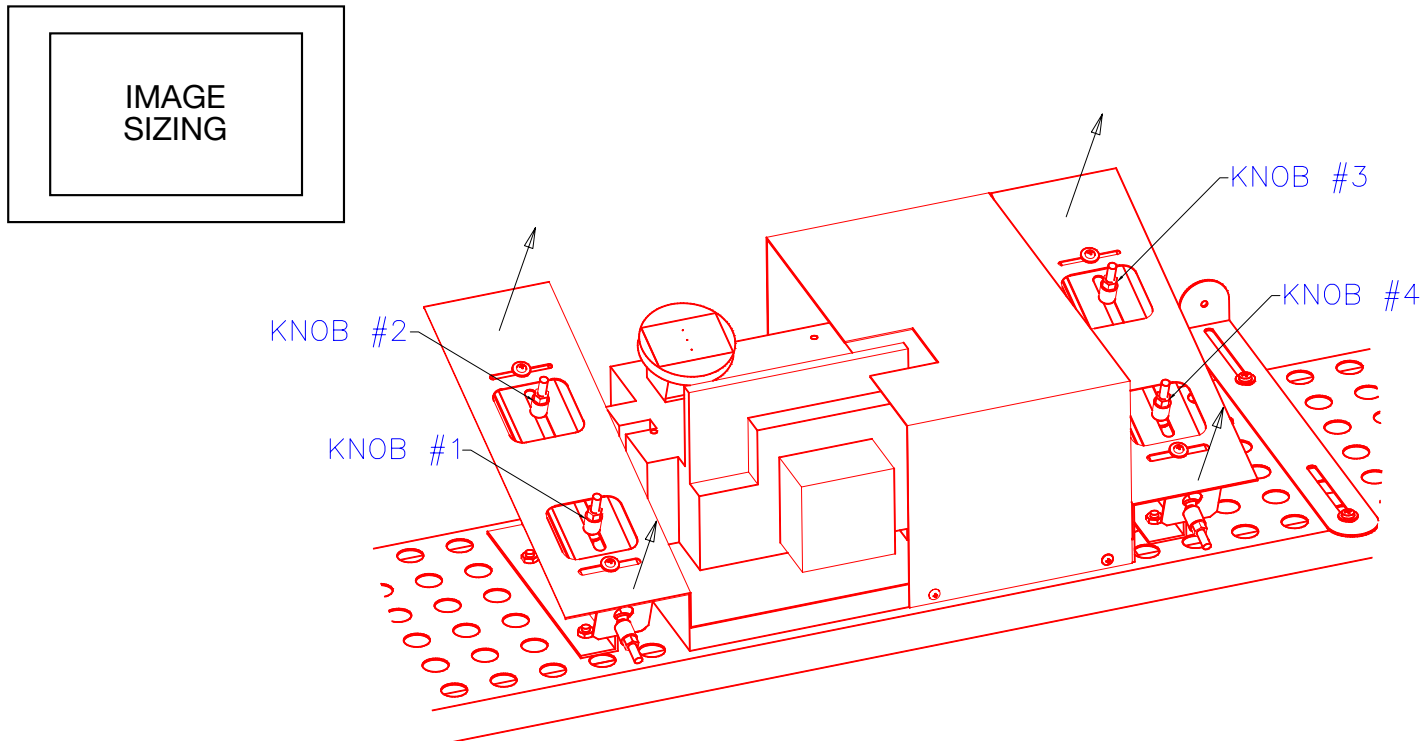

Appendix A: Cable Wiring/Connections

Cables:



Cable 1 – DVI Cable



Cable 2 – HDMI Cable



Cable 3 – 12V Trigger



**Cable 4 – 14 pin (2x7)
L/E power**



Cable 5 – Fan Cable 1



Cable 6 – Fan Cable 2



Cable 7 – Thermal Switch Cable

Connectors:

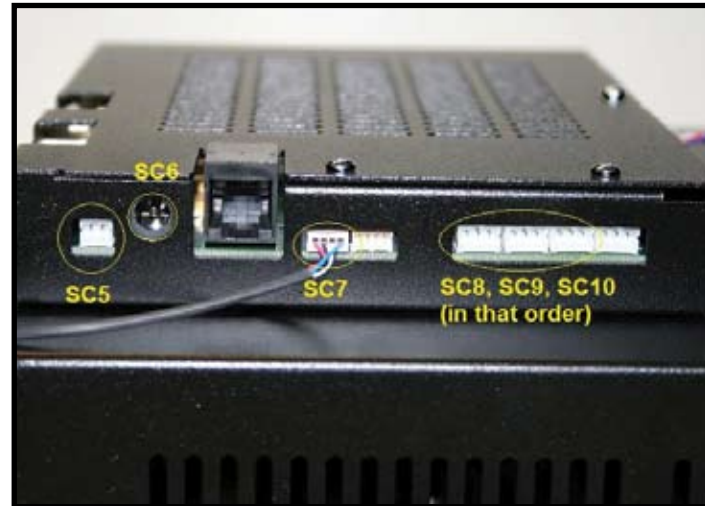
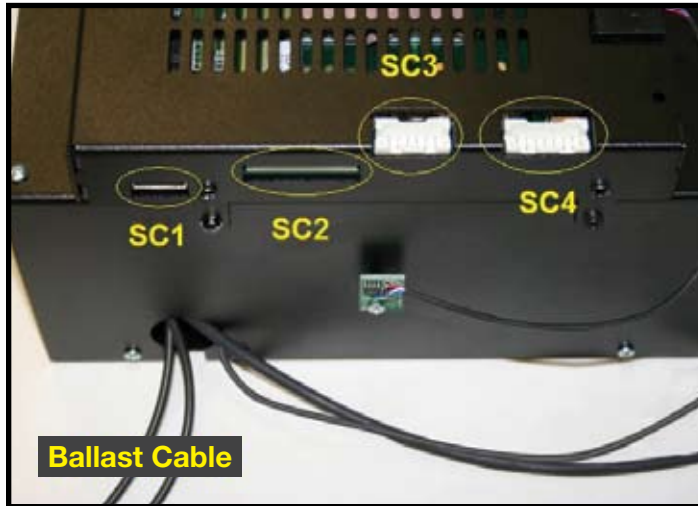

Connectors: (Continued)

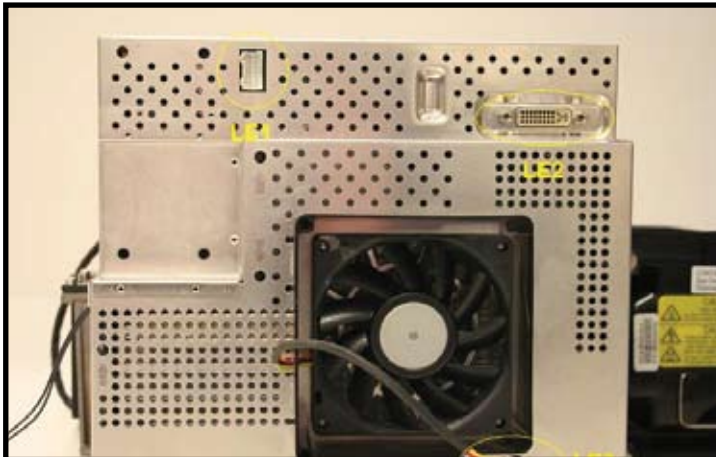

Instructions:

Connectors SC2, SC3, SC7, SC10 and SC11 are connected at the factory. To connect the rest of the cables, follow the procedures below.

NOTE: Cables 3 through 7 each have two different ends and only fit in their proper locations in one orientation. Do not force any of the cables in if they do not fit. Doing so may damage the cables and/or their respective housings.

- 1) Connect Cable 1 from the DVI slot SC12 on the system command board to the DVI slot LE2 on the light engine.
- 2) Connect Cable 2 from the HDMI slot SC1 on the system command board to the HDMI out slot on the HD3000.
- 3) Connect Cable 3 from the 12V trigger plug SC6 on the system command board to the 12V trigger plug on the HD3000.
- 4) Connect Cable 4 from the 14-pin plug SC4 on the system command board to the power plug LE1 on the light engine.
- 5) Connect Cable 5 from the fan power plug SC8 on the system command board to the power cable LE6 on the lamp fan.
- 6) Connect Cable 6 from the fan power plug SC9 on the system command board to the power cable LE3 on the DMD fan.
- 7) Connect Cable 7 from the thermal switch plug SC5 on the system command board to the thermal switch cable LE5.
- 8) Connect the ballast cable to the lamp power plug LE4 and screw it down.

The schematics of these connections can be found on the next page.

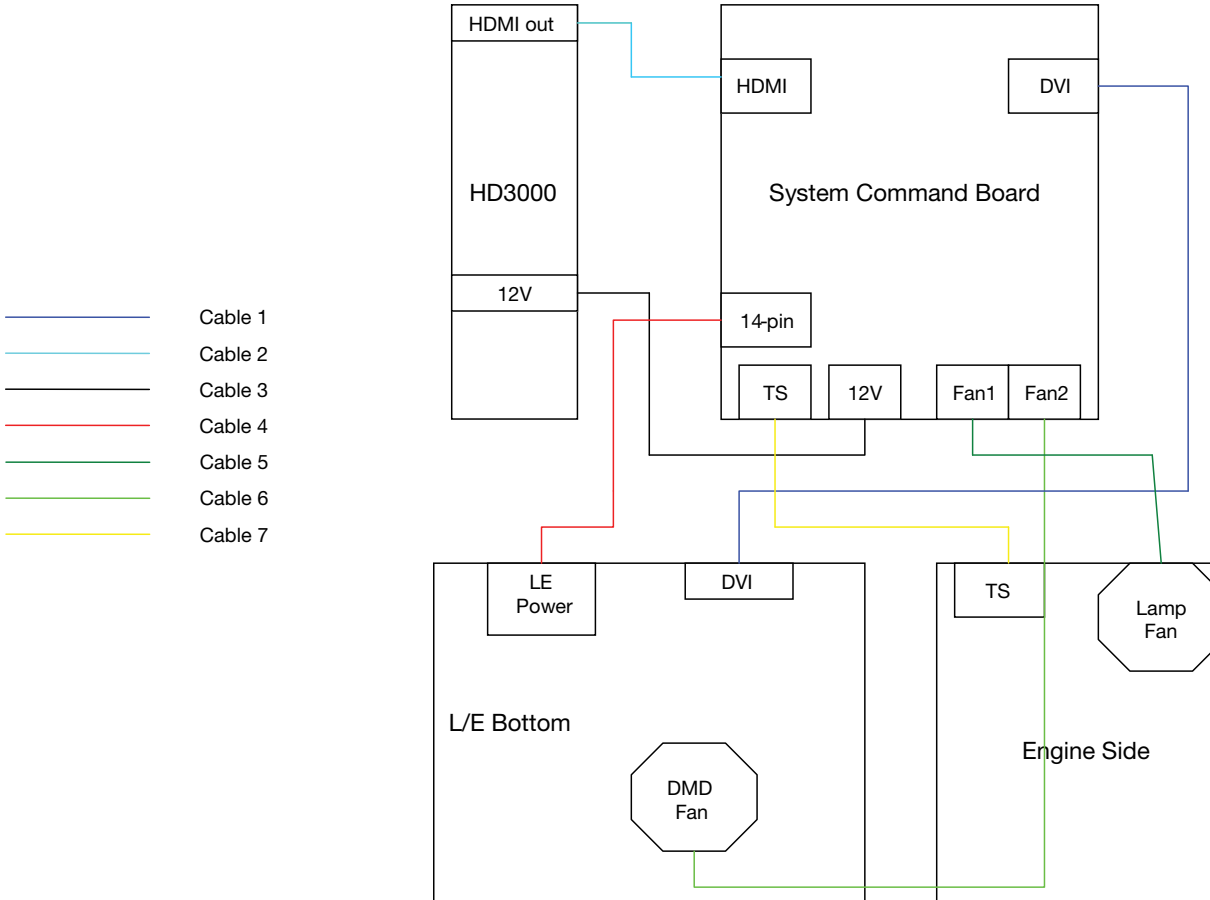

Appendix B: Discrete IR/RS-232C Codes

HD3000 RS-232C Protocol Function List

Interface

3 wires RS-232C Protocol
Baud Rate : 57600
Data Bits: 8
Parity: None
Stop Bits: 1
Flow Control :None

Command Sequence

Write	Basic Protocol
Header :	''*
Address Code :	'0' fixed
Command Code :	ASCII Text
Data :	Fixed 3 digits
Terminator Code :	Carriage Return

Acknowledgement

	Basic Protocol
Receive OK (in standby mode)	*000<CR>
Receive OK (in normal mode)	*010<CR>
Invalid Command	*001<CR>

Function List

Function Description	Basic(Original)	Basic (Update)
Power On	*0IR001<CR>	
Power Off	*0IR002<CR>	
Menu	*0IR003<CR>	
Up	*0IR004<CR>	
Down	*0IR005<CR>	
Left	*0IR006<CR>	
Right	*0IR007<CR>	
Enter	*0IR008<CR>	
Re-Sync	*0IR009<CR>	
Source-CVB1	*0IR010<CR>	
Source-CVB2	*0IR011<CR>	
Source-CVB3	*0IR012<CR>	
Source-S Video1	*0IR013<CR>	
Source-S Video2	*0IR014<CR>	
Source-S Video3	*0IR015<CR>	
Source-YPbPr1	*0IR016<CR>	
Source-YPbPr2	*0IR017<CR>	
Source-BNC1	*0IR018<CR>	
Source-BNC2	*0IR019<CR>	

HD3000 RS-232C Protocol Function List (Continued)

Function Description	Basic(Original)	Basic (Update)
Source-HDMI1	*0IR020<CR>	
Source-HDMI2	*0IR021<CR>	
Source-HDMI3	*0IR022<CR>	
Source-VGA	*0IR023<CR>	
Aspect Ratio- 16:19	*0IR024<CR>	
Aspect Ratio- 4:3	*0IR025<CR>	
Aspect Ratio- Native	*0IR026<CR>	
Aspect Ratio- Format1	*0IR027<CR>	
Aspect Ratio- Format2	*0IR028<CR>	
Aspect Ratio- Format3	*0IR029<CR>	
Model-ISF Day	*0IR030<CR>	
Model-ISF Night	*0IR031<CR>	
Mode-User1	*0IR032<CR>	
Mode-User2	*0IR033<CR>	
Mode-User3	*0IR034<CR>	
Zoom In	*0IR035<CR>	
Zoom Out	*0IR036<CR>	
Shift Up	*0IR037<CR>	
Shift Down	*0IR038<CR>	
Gamma	*0IR039<CR>	
Image Mode	*0IR040<CR>	
NR	*0IR041<CR>	
Sharpness	*0IR042<CR>	
Color	*0IR043<CR>	
Contrast	*0IR044<CR>	

Appendix C: Exploded View of the Product

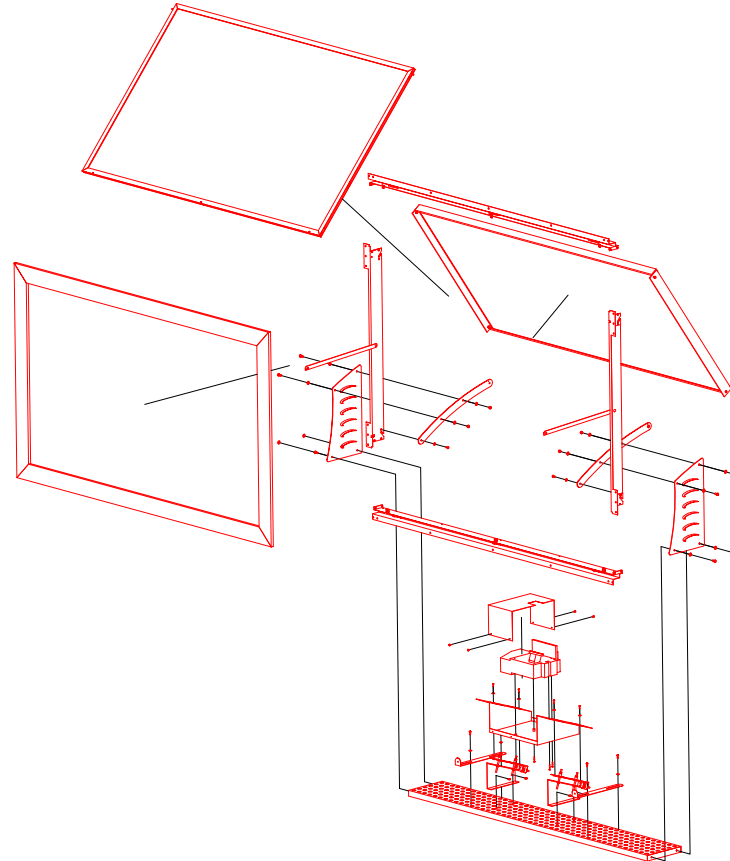



A world map composed of a grid of small dots, rendered in a dark gray color against a black background. Two callout boxes are positioned over the map: one over North America (USA) and one over Canada. Each callout box is a light gray rectangle with a white dot at its top-left corner, from which a white line extends to a white dot on the map, indicating the location of the respective office.

Canada

5630 Kennedy Road
Mississauga, ON, L4Z 2A9
Tel: 905-882-4228
Fax: 905-882-4229
www.optoma.ca

USA

715 Sycamore Drive
Milpitas, CA 95035
Tel: 408-383-3700
Fax: 408-383-3702
www.optomausa.com

Optoma Technology, Inc.

715 Sycamore Drive, Milpitas, CA 95035 • Tel: (408) 383-3700 • Fax: (408) 383-3702

Specifications subject to change without notice. Copyright © 2006 Optoma Technology, Inc. All rights reserved. www.optoma.com. All Manuals Search And Download.



Optoma
High-Definition Lifestyle

Free Manuals Download Website

<http://myh66.com>

<http://usermanuals.us>

<http://www.somanuals.com>

<http://www.4manuals.cc>

<http://www.manual-lib.com>

<http://www.404manual.com>

<http://www.luxmanual.com>

<http://aubethermostatmanual.com>

Golf course search by state

<http://golfingnear.com>

Email search by domain

<http://emailbydomain.com>

Auto manuals search

<http://auto.somanuals.com>

TV manuals search

<http://tv.somanuals.com>