

**SuperView 3000**  
**Video Windowing System**  
**User Manual**

RGB Spectrum  
950 Marina Village Pkwy.  
Alameda, CA 94501  
P/N 350-7322  
May 9, 2002



## TABLE OF CONTENTS

|                  |  |
|------------------|--|
| <i>Chapter 1</i> | <i>Introduction</i> 1                                |
|                  | General  |
|                  | Window Inputs  |
|                  | Output   |
|                  | Video Overlays – Chroma Key                          |
|                  | Control of the SuperView                             |
|                  | System Features                                      |
| <i>Chapter 2</i> | <i>Supplied Components</i> 5                         |
|                  | Standard Supplied Components                         |
|                  | Optional Items                                       |
| <i>Chapter 3</i> | <i>System Basics</i> 7                               |
|                  | System Independence                                  |
|                  | Control of the SuperView                             |
|                  | Windows  |
|                  | Selecting and Displaying Windows–Serial Port Control |
|                  | Visibility of Window Imagery                         |
|                  | Autosync and Free-Run Display Modes                  |
| <i>Chapter 4</i> | <i>Installation and System Set Up</i> 15             |
|                  | Connectors   |
|                  | Installing the SuperView                             |
|                  | Set Up: Autosync Mode                                |
|                  | Set Up: Free-Run Mode                                |
| <i>Chapter 5</i> | <i>Front Panel Control</i> 19                        |
|                  | General  |
|                  | Image Menu   |
|                  | Input Menu   |
|                  | Output Menu  |
|                  | Window Menu  |
|                  | Miscellaneous Menu                                   |
|                  | Status Menu  |
|                  | Presets  |

|                   |   |           |
|-------------------|---|-----------|
| <i>Chapter 6</i>  | <i>Serial Command Set</i>               | <i>27</i> |
|                   | General                                 |           |
|                   | Serial Command Set Usage                |           |
|                   | Control Software For Windows            |           |
| <i>Chapter 7</i>  | <i>Technical Specifications</i>         | <i>39</i> |
| <i>Chapter 8</i>  | <i>Troubleshooting</i>                  | <i>41</i> |
|                   | Troubleshooting Guide                   |           |
|                   | How to Contact RGB Spectrum             |           |
|                   | Firmware Updates/README Files           |           |
| <i>Appendix A</i> | <i>RS-232 Control</i>                   | <i>45</i> |
|                   | Connecting the RS-232 Port              |           |
| <i>Appendix B</i> | <i>Video Levels and Chroma Key</i>      | <i>49</i> |
| <i>Appendix C</i> | <i>Updating System Firmware</i>         | <i>53</i> |
| <i>Appendix D</i> | <i>Serial Control of Multiple Units</i> | <i>55</i> |
|                   | MPSD Commands                           |           |
|                   | MPSD Example: Baud Rate Change          |           |
| <i>Appendix E</i> | <i>Product Warranty</i>                 | <i>59</i> |
|                   | Warranty                                |           |
|                   | Extended Warranty                       |           |

# INTRODUCTION

---

## GENERAL

---

The SuperView 3000 video windowing system displays up to twelve live video/computer windows on a high-resolution, RGB display device.

Each channel accepts high-resolution RGB, Y PB PR Component, composite video, and S-Video sources for simultaneous display in windows on a high-resolution, RGB display device. The system comes standard with four input channels. Additional input channels can be added, up to a maximum of twelve window inputs. Each input signal can be independently scaled, positioned, and zoomed.

The standard SuperView processor operates in a *Free-run* mode, outputting a high-resolution image, at a user-selected scan rate.

As an option, a background input can be included that allows windows to be combined with the high-resolution “background” generated from a computer or image generator. This is called *Autosync mode*. Each window is displayed on the output display, inserted on top of the background image, with the option of overlaying windows with the background text and graphics.

An optional front panel is also available for control of most system functions. RS-232 is the standard remote control method, allowing access to all the SuperView processor’s functionality.

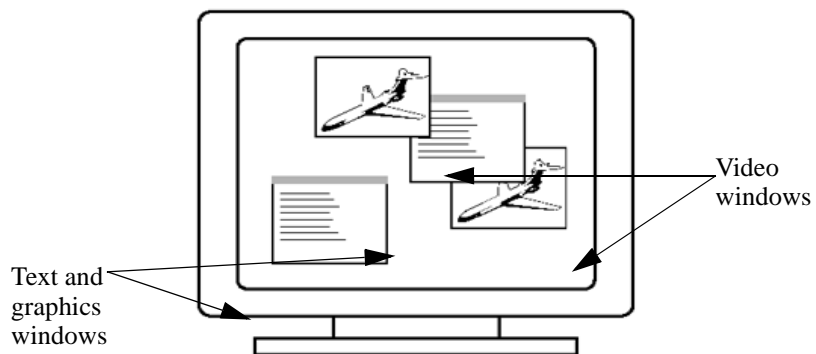

FIGURE 1. SuperView Displays Multiple Inputs on a Single Monitor

## WINDOW INPUTS

Each channel on the SuperView accepts four types of inputs—NTSC or PAL Composite, S-Video, Y PB PR Component, and RGB. All of the input connectors can be populated with sources but only one is displayed at a given time. Note that the Component and RGB are on one connector so you use that channel for either RGB *or* for component video.

Video inputs can come from such devices as a TV camera, video cassette recorder, DVD player, or video teleconferencing system. Analog RGB inputs typically come from a computer and can be interlaced or non-interlaced, up to 1600x 1200 pixels, and between 15 and 90kHz. The computer inputs can be of any sync format (sync on green, composite sync, or separate H- and V-drive).

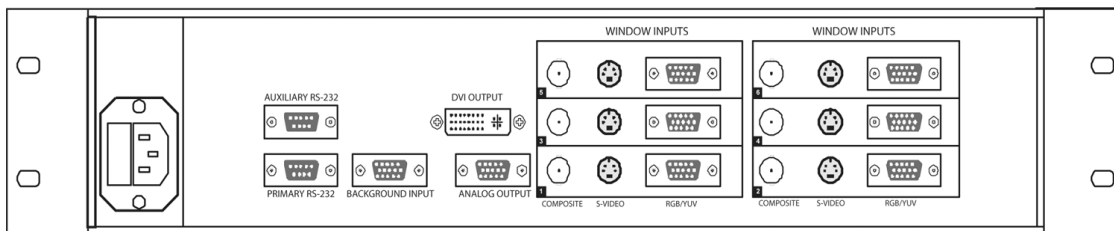

FIGURE 2. SuperView Rear Panel, with Six Inputs in a 2RU Enclosure

## OUTPUT

All input signals to the SuperView are converted for display in the output high-resolution format, up to 1600 pixels by 1200 lines, with horizontal scan rates from 15 to 100 kHz.

If you have the optional **BACKGROUND INPUT** connector, then the output of the SuperView can sync to an incoming (background) signal. The SuperView can either insert the windows on top of the background graphics, or selectively combine the window inputs with the background computer image (chroma key mode).

If no background signal is connected, the SuperView is operated in free-run mode and the user can configure the resolution, frequency, and sync format of the output signal.

The output is available on the **ANALOG OUTPUT** connector and can be connected to a computer monitor or to other high scan-rate display devices.

The SuperView also offers an optional DVI digital output, up to 1280x1024 pixels.

## VIDEO OVERLAYS – CHROMA KEY

The SuperView provides chroma key circuitry for overlaying the window input imagery with the background computer graphics (gray scale or color). This feature is only available if you have the Autosync option and the **BACKGROUND INPUT** connector.

## CONTROL OF THE SUPERVIEW

### FRONT PANEL

Many of the SuperView's functions can be controlled from the front panel. These include: Window Size, Window Position, Zoom, Pan, Window Priority, Motion Filter, Brightness, Contrast, Saturation, Gamma, Freeze, and ChromaKey.

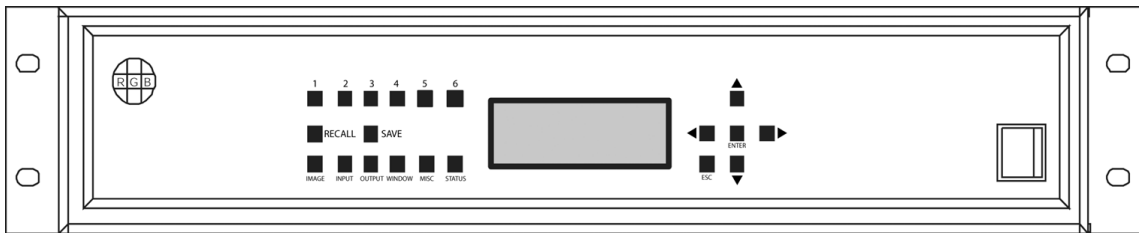

FIGURE 3. SuperView Front Panel, 2RU Enclosure

### RS-232

The SuperView has a **PRIMARY RS-232** serial port which connects to an ASCII terminal or to any computer with a serial port. Commands are sent from the terminal or computer to the SuperView. The commands have a simple syntax and are described in Chapter 6, "Serial Command Set".

The SuperView also has an **AUXILIARY RS-232** port, which allows multiple SuperViews to be daisy-chained and controlled by a single terminal or computer. Certain other products from RGB Spectrum also have two serial ports, allowing these units to be part of the chain.

## SYSTEM FEATURES

- Accepts up to twelve inputs—each input channel accepts NTSC/PAL Composite, S-Video, Y PB PR Component, and high-resolution RGB signals.
- Up to six user-defined presets can be stored and recalled for later use. These presets store information about window size and position, image controls, and overall arrangement of inputs on the screen.

- Input windows can be positioned, scaled, overlaid with computer text and graphics, and clipped to an arbitrary size or shape. Scaling of each window is continuous up to the full size of the display raster. Zooming in on a region of interest is also supported.
- The graphic overlay capability uses a versatile chroma keyer. Keying can be performed on black, white, or a user-defined color. Active windows show through the regions of the background high-resolution input drawn with the chroma key color.
- Windows are controlled by an optional front panel or via the RS-232 serial port.
- Many control parameters are automatically saved in nonvolatile memory and can be recalled for later use.
- The background input is compatible with signals from a wide range of RGB sources, up to 1600x1200.
- The processor may be genlocked to an external signal, up to 1600x1200 pixels.
- The system provides a high-resolution analog RGB output, for display on a computer monitor or high scan rate projector.
- The system automatically detects and locks to all computer sync signals. Industry standard and custom video timings are supported.
- Each input window can be individually frozen.
- Full 24-bit color processing is used throughout.
- Optional control software for Microsoft Windows environments is available from RGB Spectrum.



# SUPPLIED COMPONENTS

## STANDARD SUPPLIED COMPONENTS

The following equipment is included in your SuperView's shipping carton:

**TABLE 1. Standard Supplied Components**

| Item                                 | Part Number            |
|--------------------------------------|------------------------|
| SuperView                            | ---                    |
| SuperView User Manual                | 350-7322               |
| Power cord (110 or 220 volt)         | 520-1188 or 520-0271-1 |
| Spare fuse - installed in IEC socket | 180-7207               |
| Equipment Warranty Registration Card | 330-5477               |

## OPTIONAL ITEMS

RGB Spectrum provides other equipment which may be useful in operating the SuperView. These items may be purchased separately:

**TABLE 2. Optional Items**

| Item               | Part Number | Description  |
|--------------------|-------------|--|
| VGA Cable          | 520-0298-1  | 15-pin HD Male to 15-pin HD Male, 6 ft. This cable can be used to connect your analog output/inputs to sources with a female VGA connector.              |
| VGA-to-BNC Adapter | 520-0251-1  | 15-pin HD Male to a 5 BNC cable bundle Male, 6 ft. 10 inches. This cable can be used to connect the analog output/inputs to sources with BNC connectors. |

TABLE 2. Optional Items

| Item              | Part Number | Description   |
|-------------------|-------------|---|
| VCP for SuperView | 720-7295    | Virtual Control Panel for the SuperView. This is a Windows compatible software application that provides a graphical user interface to serial control of a SuperView. |
| DVI cable         | ---         | This cable is used to connect the optional DVI digital output to a DVI-capable display device. Contact RGB Spectrum for details.                                      |

## SYSTEM BASICS

The SuperView 3000 video windowing system displays up to twelve live video/computer windows on a high-resolution, RGB display device.

Each channel accepts RGB, component video, composite video, and S-Video sources for simultaneous display in windows on a high-resolution, RGB display device. Each video signal is displayed in a dedicated window on the output display, and can be independently scaled, positioned, and zoomed.

### SYSTEM INDEPENDENCE

The SuperView can be operated either in Autosync mode with a host computer input contributing a background image and providing the output signal characteristics, or in Free-run mode with the user specifying the output signal. Autosync mode has two different states. If the background signal is connected and visible, this is referred to as *background* Autosync mode. If the signal is connected but turned off, then this is referred to as *genlock* Autosync mode; the output characteristics of the signal are provided even though the signal is not visible. Note that the Autosync mode is only available if your system has the optional **BACKGROUND INPUT** connector.

In Autosync mode, SuperView windows are combined with a high-resolution "background" signal generated from a host computer or image generator. The host computer can be a Sun, HP, DEC, IBM, or SGI workstation, or a PC-compatible. The only requirement is that the computer produces analog RGB output with a pixel resolution between 640x480 and 1600x1200, at a horizontal scan rate between 15 and 100kHz.

### CONTROL OF THE SUPERVIEW

#### FRONT PANEL

An optional front panel is available for control of the SuperView. The front panel allows you to select and adjust any of your windows, save and recall preset configurations, and adjust your output display. Even if you ultimately intend to control the SuperView over the serial port, the front panel allows you to get "up and running" quickly, and provides some feedback on input and output status.

#### SERIAL PORT

The SuperView can be controlled with ASCII commands sent from a computer, or serial console, via the serial port. During your initial experimentation with the SuperView serial port, you will probably find it easier to use a terminal, or a

terminal-emulator program (i.e. Hyperterminal or Procomm) running on a computer, in order to try out the examples listed in this manual. Optionally, RGB Spectrum offers software control programs for Microsoft Windows environments.

In this chapter, we will relate our discussion of basic operational concepts to the SuperView's ASCII Command Set. Commands can be issued manually, via the terminal, or from an application program, to the SuperView's serial port.

## WINDOWS

Each input to the SuperView is displayed in its own window on the high-resolution display device. A window's size, position, video, and image parameters are controlled using either the front panel or serial port commands that identify the desired window as being "1", "2", "3", "4", "5", or "6."

In the factory default configuration, window 1's top left corner is placed 50 pixels to the right of the monitor's top left corner, and 50 lines down from the top—i.e., at the screen position (50, 50). Window 2 starts another 50 pixels over and another 50 lines down—i.e., at (100, 100). Window 3 starts at (150, 150) and window 4 at (200, 200), etc. The exact positioning of the windows may differ from that described above, depending on the resolution of the output. Also note that only RGB inputs will be visible by default; video inputs signals will not be displayed until you change the input type for a particular window.

## SELECTING AND DISPLAYING WINDOWS— SERIAL PORT CONTROL

This section discusses the interaction of zoom, pan, window size, and window position and their control via the serial port. These concepts are important if you are controlling the SuperView from the serial port. If you are using the front panel to control the SuperView, you may skip to Chapter 5, "*Front Panel Control*".

The SuperView maps a user-specified *portion* of each live input into a dedicated window on the monitor. This process involves both a *source* and a *destination* rectangle.

### IMAGE RECTANGLES

Image scaling and window size, positioning and clipping (at the edge of the screen) are all affected by the source and destination rectangles for each window input. Both rectangles are adjustable via the front panel or using the Command Set.

A *source rectangle* selects a rectangular portion of an input image, and this portion is seen in a window on the monitor. Typically, the source rectangle is defined to contain the entire image. Only the currently selected portion of each

input image can be viewed, and it is shown in only one window. The SuperView automatically changes an input's source rectangle as you use various front panel zoom and pan controls to select and zoom in on portions of the full-size image.

A *destination rectangle* specifies a window's size and screen position. The content of the window is the imagery defined by the source rectangle.

To help you understand what the specification of source and destination rectangles involves, we will explain the nature of these rectangles in more detail. The source rectangle for each input is defined in terms of the input image's coordinate space—its top left corner is positioned using these coordinates, and its width and height are defined the same way. Similarly, each input's destination rectangle is defined in terms of the screen space coordinates of the monitor. Each window is sized and positioned on the monitor as specified by its destination rectangle.

Next, we'll look at some examples of how to specify the coordinates of source and destination rectangles.

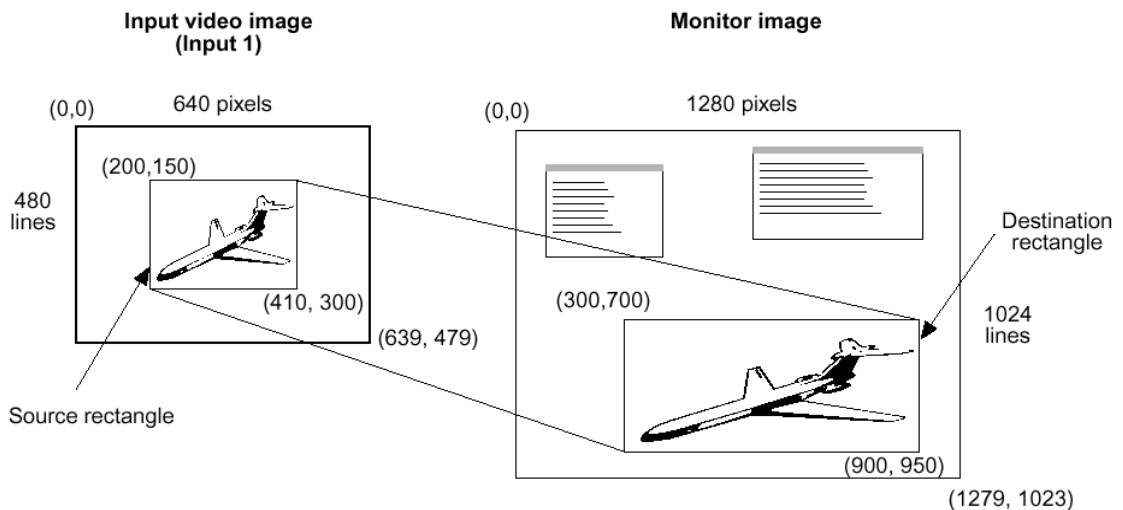

FIGURE 4. Selection of an Image Segment for Display in a Window

## SERIAL CONTROL

The selection of source and destination rectangles is achieved with the **WSR** and **WDR** commands.

*Example*—define the source rectangle in Figure 4. That is, for window 1, set the rectangle's top left corner to begin at (200, 150) of the input image, and use a section 210 pixels wide and 150 lines high:

```
>wsr 1 200 150 210 150
```

*Example*—define the destination rectangle in Figure 4. That is, place the top left corner of window 1 at (300, 700) of the display's raster, and use a window 600 pixels wide and 250 lines high:

```
>wdr 1 300 700 600 250
```

The SuperView provides query commands that let you get the current value(s) of most system parameters.

*Example*—query the SuperView on the current **WDR** values for window 1:

```
>wdr 1
```

The system responds by listing the frame buffer coordinate values:

```
>300 700 600 250
```

## ASPECT RATIO

Any desired rectangular portion of an input image can be displayed in the corresponding window. Also, the window itself can be set to have any rectangular shape and be any desired size on the monitor, up to the full size of the output raster. The size and shape of the source rectangle are *independent* of the destination rectangle's size and shape. This has important consequences.

Let us suppose that you defined an input's source and destination rectangles so that the central 320 pixels by 240 lines of a video source image were mapped into a 640x480 window. In this case, the destination rectangle is larger than the source rectangle, but has the same shape and the same width-to-height aspect ratio (4:3). Thus, the original input image is scaled equally in both dimensions for display on the monitor.

Varying the destination rectangle's size but preserving its aspect ratio makes the displayed image larger or smaller. As long as its proportions correspond to those of the source rectangle, the displayed image will resemble the input image. If you *independently* vary the shape of either the source or destination rectangle, so that their aspect ratios are no longer the same, your displayed picture will appear stretched or squeezed compared to the original image. Figure 4 shows how the image is stretched by using a destination rectangle with a different, more elongated shape than that of the source rectangle.

## POSITIONING AND CLIPPING

A window can be positioned anywhere on the output raster. If the window's destination rectangle is defined so that a portion of the window is off the screen, that portion of the windowed image is clipped (until it is moved back into view). This "image clipping" is illustrated in Figure 5. The window is positioned by specifying the screen coordinates of its top left corner. Negative coordinate values clip from the left and top edges of the window.

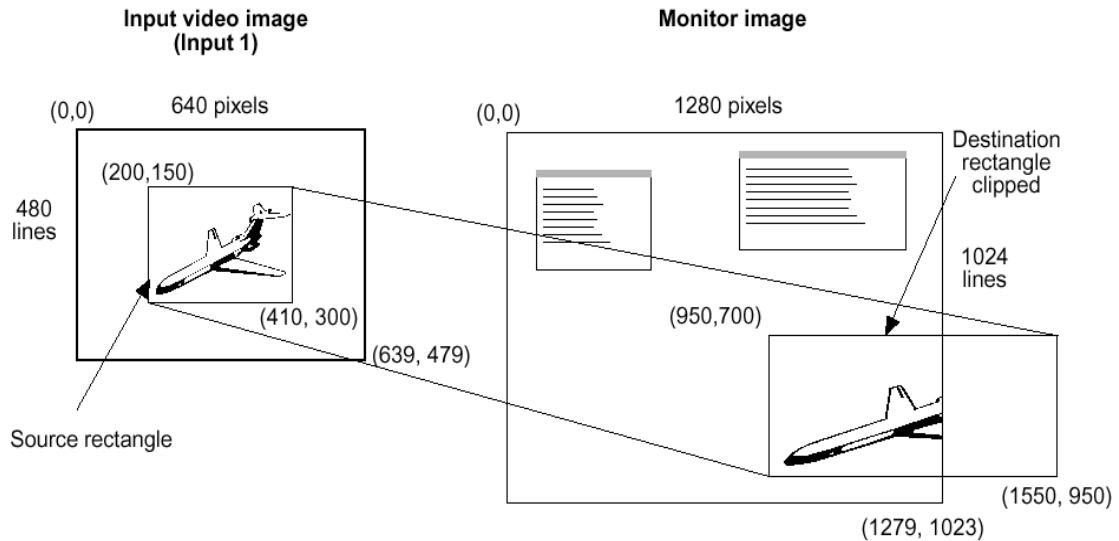

FIGURE 5. A Clipped Window

## VISIBILITY OF WINDOW IMAGERY

The SuperView's output consists of a high-resolution image assembled from a specified number of input images. It is important to understand which of these inputs will be visible on the monitor.

The following factors determine the visibility of window imagery and background host computer graphics:

- The window's source must be active and connected to an input channel that is turned on.
- A window or windowed region of interest must be unobstructed by other windows.
- The SuperView must be operating in the appropriate display mode to show window imagery with or without computer graphics, as preferred.

We will now consider the first two factors listed above. The third factor—the SuperView's display mode—is discussed in "Autosync and Free-Run Display Modes" on page 13.

## TURNING WINDOWS ON

The first factor determining whether a window input will be visible is simple—the source must be powered on and properly connected to one of the SuperView's input channels. Also, the channel's associated window must itself be turned on. The **WINDOW <window#> <ON|OFF>** command turns windows on and off.

Example—turn window 2 on:

```
>window 2 on
```

**PRIORITY  
LEVELS**  
.....

The SuperView uses window priority levels to determine which of several overlapping windows are visible. You can change the priority levels of windows so that different ones come into the foreground and others move to the background.

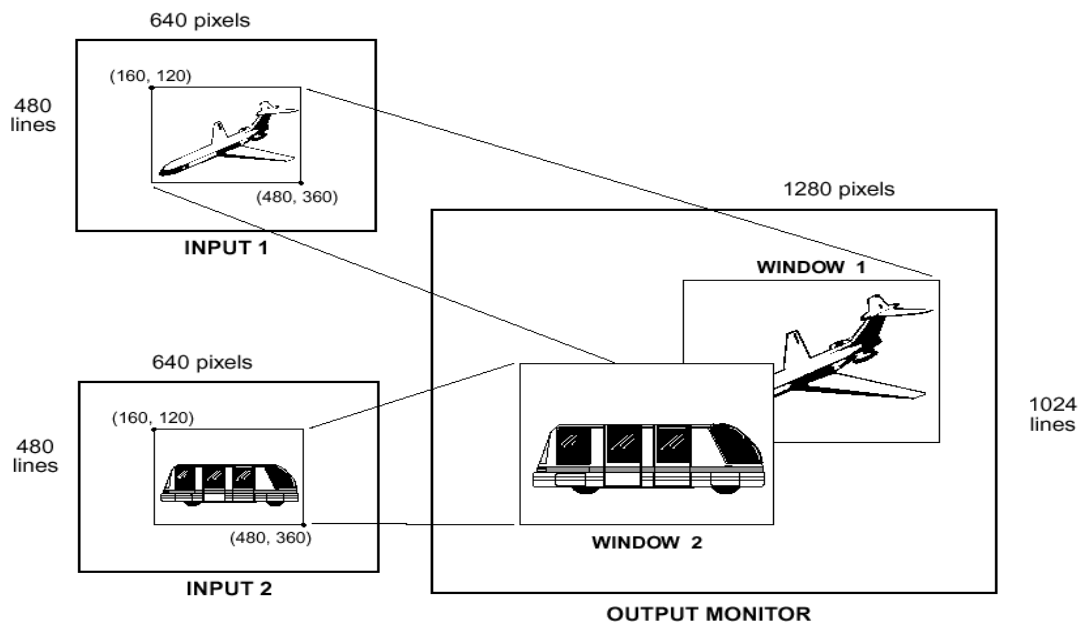

FIGURE 6. Window Priority—Window 2 has Higher Priority

When windows overlap, their relative visibility depends on their respective user-assigned priority levels (see Figure 6). The available levels are one through six for a six-window system; up to twelve for a twelve-window system, where one represents the highest priority. The window with the highest priority is the one that is displayed on top; windows with lower priorities are stacked beneath it. However, keep in mind that only the overlapped region of a window is actually obscured by a higher priority window.

No two windows may have the same priority level. If, for example, one window's priority is increased, the window previously holding that priority is decreased one priority level. Promoting (or demoting) one window leaves the priorities of the other windows unchanged relative to each other.

Priority levels are assigned with the **PRiority <window#> <1..12>** command. (This assumes a twelve-window SuperView.)



Example—set window 2 to priority level 1:

>priority 2 1

Since level one corresponds to the highest priority level, window 2 has priority over all other video windows, and hides any overlapped window with a lower priority level.

## AUTOSYNC AND FREE-RUN DISPLAY MODES

The SuperView provides two display modes—two different ways to apply host computer graphics and window inputs to the screen. The two display modes are *Autosync* and *Free Run*.

### AUTOSYNC MODE

*Autosync* combines the background computer graphics and any enabled windows. Autosync mode has two different states. If the background signal is connected and visible, this is referred to as *background* Autosync mode. If the signal is connected but turned off, then this is referred to as *genlock* Autosync mode; the output characteristics of the signal are provided even though the signal is not visible. Note that the Autosync mode is only available if your system has the optional **BACKGROUND INPUT** connector.

With the *background* Autosync mode, the individual input windows can be displayed in two ways—inserted on top of the computer graphics background, or selectively displayed replacing certain areas of the computer graphics where key color criteria are met (Chroma Key option).

In normal Autosync mode, window inputs have priority over the background computer graphics. The windows are “inserted” on top of the computer graphics background. Wherever a visibility rectangle indicates the presence of input window imagery, the imagery is displayed at the corresponding display’s position. Any background computer imagery at those pixel positions is not visible. Even the computer mouse pointer is hidden if its position coincides with an input window.

Autosync mode is an optional mode that is available only if you have the **BACKGROUND INPUT** connector. Autosync mode requires a host computer input and at least one window input. A SuperView in Autosync mode must have a host computer connected to the **BACKGROUND INPUT** to generate an output.

### CHROMA KEY OPTION

In this Autosync display option, windows *selectively* replace the background computer graphics, based on the color of the graphics. That is, if the SuperView detects the background contains a color within a user-specified chroma key “acceptance range” *and*, at that *same* position, there exists any portion of an active input window, then the input window replaces the background computer graphics at the corresponding display position. This is the same technique used

to place TV weather people in front of live satellite images. The color that is replaced by the video window is adjustable (via serial command) to include any range of RGB color values.

The chroma key option can only be turned on when the SuperView is used with a host computer input connected at the **BACKGROUN INPUT** connector, and the SuperView is in Autosync display mode.

The chroma key option is selected with the **ChromaKey ON** command. Chroma key is discussed in greater detail in Appendix B, "*Video Levels and Chroma Key*".

**FREE RUN**  
.....  
**MODE**  
.....

In Free-run mode, which involves only window inputs, the windows are displayed on a black background and the output is driven by an internally generated sync. Free-run mode is selected with the **HOST FREE** command.

Free-run mode also requires that you set the output timing parameters for the SuperView. Refer to "*Set Up: Free-Run Mode*" in Chapter 4 for additional details.

# INSTALLATION AND SYSTEM SET UP

## CONNECTORS

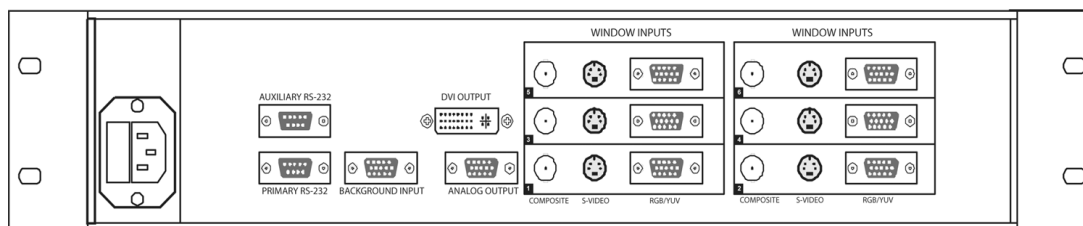

**FIGURE 7. SuperView Rear Panel, With Six Inputs in a 2RU Enclosure**

The figure above illustrates the rear panel of a 2U SuperView configured with six input windows. The connectors, their physical type and gender, are listed in the table below.

**TABLE 3. Connector Types**

| Connector                    | Physical Type   | Gender |
|------------------------------|-----------------|--------|
| Composite video window input | BNC             | Female |
| S-Video input window input   | 4-pin mini-DIN  | Female |
| RGB/YUV window input         | 15-pin HD D-Sub | Female |
| Analog Output                | 15-pin HD D-Sub | Female |
| DVI Output (optional)        | DDWG DVI        | Female |
| Background Input (optional)  | 15-pin HD D-Sub | Female |
| Auxiliary RS-232             | 9-pin D-Sub     | Female |
| Primary RS-232               | 9-pin D-Sub     | Female |

The 3U chassis is configurable with any even number of window inputs up to a maximum of twelve. Input cards are always added in pairs.

## INSTALLING THE SUPERVIEW

To install a SuperView, follow the steps outlined below:

### STEP 1: POWER

Connect a power cord to the SuperView. The SuperView is equipped with a universal, 100-220 V, 50-60 Hz power supply.

### STEP 2: CONNECT WINDOW SOURCES

Connect your video and/or computer sources to the windows labeled **1-12**

The SuperView can have as many windows as it is configured for. You can connect multiple types of sources to each numbered window—a Composite source, an S-Video source, and either a Component or RGB source. Though all the connectors can be populated with sources, you will have to choose which one to display since only one source can be displayed per window.

### STEP 3: CONNECT A BACKGROUND INPUT (OPTIONAL)

If you are going to use the SuperView in *Autosync* mode, you will need to connect your computer's high-resolution output to the connector labeled **BACKGROUND INPUT**. This is the computer that will provide the background source for the SuperView and it can be up to 1600x1200 pixels.

### STEP 4: CONNECT THE ANALOG/DIGITAL OUTPUT

Connect the **ANALOG OUTPUT** of the SuperView to the desired display device. This device must be able to accept RGB inputs of at least 100 kHz.

You can also connect the **DVI OUTPUT** to the desired display device. This option can be used in lieu of, or in addition to, the analog output.

### STEP 5: CONNECT SERIAL PORT

If you wish to control the SuperView from the serial port, connect the COM port of your computer or other terminal control device to the **PRIMARY RS-232** connector. Using a terminal emulation program (i.e. Hyperterminal or Procomm), you can then control the SuperView using ASCII serial commands.

## CONTROLLING MULTIPLE UNITS

The **AUXILIARY RS-232** serial communications port is provided to implement daisy-chaining of multiple systems. The Auxiliary port of an upstream unit is connected to the Primary port of a downstream unit (Figure 8). When a unit is not selected, it passes all commands to its downstream port, and passes all

responses from its Auxiliary port back to the console. See Appendix D, “Serial Control of Multiple Units,” for details.

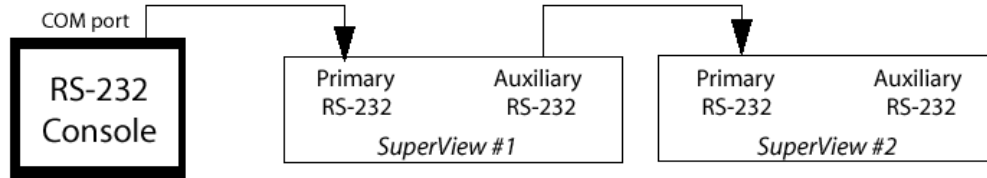

FIGURE 8. Serial Control of Two SuperViews

## SET UP: AUTOSYNC MODE

In Autosync mode, the SuperView requires an external host sync source be connected at the BACKGROUND INPUT connector. The output of the SuperView will match the timing and format of the external source. Thus with a 1280x 1024 PC, running at 65kHz and 60Hz, and a separate Horizontal and Vertical drive sync format (RGBHV), the output of the SuperView will also be 1280x 1024, 65kHz and 60Hz, with separate Horizontal and Vertical sync.

Autosync is not the default mode of the SuperView. To set the unit to Autosync using the serial port, type the **HOST AUTO** command. To set the mode using the front panel, press the OUTPUT button and navigate to the *Output Sync* menu where you can set the mode to Auto.

Autosync mode has two different states. If the background signal is connected and visible, this is referred to as *background* Autosync mode. If the signal is connected but turned off, then this is referred to as *genlock* Autosync mode; the output characteristics of the signal are provided even though the signal is not visible. The two modes are controlled with the **BackGround ON|OFF** command.

### INTERACTIVE TIMING ADJUSTMENT

When the SuperView sees a new host computer video timing, it checks to see if the signal’s characteristics are in its list of stored timings. (See “Host List” on page 49.) If the characteristics are not in its list, it uses an internal algorithm to estimate the timing of the video, and configures itself appropriately. This procedure is adequate for most applications and timings, but for greater accuracy you can fine-tune and store the settings. This fine-tuning is done either by feeding the exact timing numbers (using the **HostTiming** command) or by an interactive adjustment procedure through the front panel or the serial port.

### SERIAL PORT ADJUSTMENT

To adjust timing interactively through the serial port use the **HostInteractive** command. Adjusting the timing usually takes less than five minutes. Refer to the **HostInteractive** command on page 49 for more details.

### FRONT PANEL ADJUSTMENT

To adjust the host timing from the front panel, follow the steps below.

**Step 1 - Verify connections** To perform the interactive timing adjustment, make sure the host computer is switched on and connected at the SuperView's BACKGROUND INPUT.

**Step 2 - Begin Interactive Timing Adjust (ITA)** Press the OUTPUT button and navigate through the menu to the *Output Timing Adjust* option. Press ENTER to begin the adjustment process—a white box and cross hair appear on your output display.

**Step 3 - First adjustment** Use the four directional arrow buttons to position the top left corner of the box at the top left corner of the display monitor. Press ENTER to save changes and move to the second part of ITA.

**Step 4 - Second adjustment** Use the four directional arrow buttons to position the bottom right corner of the box at the bottom right corner of the display monitor. Press ENTER to save changes.

**Step 5 - Repeat adjustment procedure** Perform the adjustment procedure for each corner twice. This repetition is necessary to accurately fine-tune the timing parameters.

**Saving adjustment** Once you have adjusted your host, you should save it to the host list. The next time you use the same host, the SuperView will recall your saved settings and use them for the output timing. To save a host, navigate through the *Output* menu until you see the menu called *Save Host*. You can press ENTER to save the host to one of the ten user-definable entries on the host list. Note that from the front panel, the default host name will be used.

Once you have completed the ITA procedure, finish the set up of your unit by addressing the different window image controls available from the front panel or through serial control. For front panel control, refer to Chapter 5 and for serial control, refer to the Command Set in Chapter 6.

### SET UP: FREE-RUN MODE

.....

In Free-run mode, the SuperView generates sync internally. Only window input sources are connected; there is no source at the BACKGROUND INPUT connector.

To set up a SuperView for Free-run operation, you can follow the same steps outlined above for the AutoSync mode. The only difference being that you do not need to have a host computer connected to the BACKGROUND INPUT connector.

Note that Free-run mode is the factory default mode of the SuperView.

## FRONT PANEL CONTROL

The front panel provides control over most SuperView functions (Figure 9). These controls include: Saving and Recalling Presets, Input and Output Timing, Window Size, Window Position, Zoom, Pan, Window Priority, Motion Filter, Brightness, Contrast, Saturation, Gamma, Freeze, and ChromaKey.

The menus for the SuperView are grouped according to function and there is one button access to all of these menus. The LCD provides access to the individual menu items.



The front panel is an optional component that you can order from RGB Spectrum when you initially purchase a SuperView. It does not come standard with the unit. If you do not have a front panel, then refer to the following chapter, Chapter 6, "Serial Command Set".

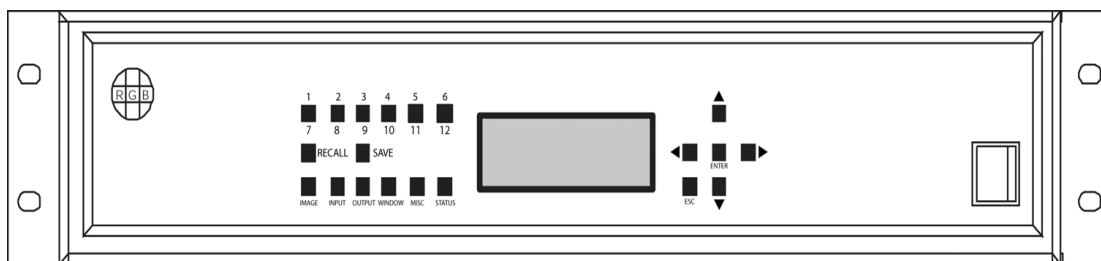

FIGURE 9. SuperView Front Panel, Twelve Input 3RU Unit

### GENERAL

There are three rows of buttons to the left of the LCD. The top row provides access to INPUTS and PRESETS. If you have a SuperView with more than six inputs, note that these buttons have dual labels and will accommodate the additional inputs. For example, pushing the button labeled "1/7" once will select input 1 and pushing the button twice will select input 7.

The SuperView handles up to six user-defined presets. The second row of buttons, used in conjunction with the top row of numbered buttons, allows you to SAVE and RECALL these presets.

The bottom row of buttons provides access to the menu system of the SuperView. These menus are discussed in greater detail later in this chapter.

The buttons to the right of the LCD allow navigation and selection through the menu system. In general, the ENTER button is used to select or confirm a parameter and the ESCAPE button is used to exit out of a parameter. The Arrow buttons are used for navigation.

All of the menus for the SuperView work in a similar way. The top line is the menu title followed by the active window in parenthesis. The remaining three lines display the first three menu items and if applicable, the current value for that input (i.e. **Brightness: -100**). For example,

|                    |
|--------------------|
| IMAGE (3)          |
| > BRIGHTNESS: -100 |
| CONTRAST: +100     |
| SATURATION: +100   |

There is a prompt (>) which indicates the active menu item. Use the arrow keys to scroll through the menu items until the menu item you want is on the active line. The menu items work in two different ways. If the menu has a fixed range of values (i.e. Brightness, Input Type, Freeze), then use the Left/Right arrow keys to step through the range of values. Once you find the desired value, press ENTER to confirm and save the new value. Pressing ESCAPE or the Up/Down arrow keys will cancel changes.

The second type of menu is an interactive menu. Examples of these are Size, Position, and Zoom. These menus have no fixed values that you can step through one at a time. For these menus, press the ENTER button to enter the interactive adjustment mode of the menu (the LCD will prompt you with instructions). Use the four arrow keys to make adjustments to the parameter. Press ENTER to confirm your changes or ESCAPE to cancel changes.

From any menu, you can switch to another input to adjust. Do this by pressing one of the numbered buttons along the top left row. The new input number will appear in parenthesis in the LCD menu. Each menu item will also be updated to reflect the current values for the new window. This feature allows you to adjust parameters for ALL of your inputs with one button press. You can stay in a system menu (i.e. Image, Input, etc.) until you have stepped through all of your inputs (1-12).

## IMAGE MENU

.....

Press the IMAGE button to access this menu. It contains all image control menus. These include Brightness, Contrast, Saturation, Hue, Sharpness, Overscan, Gamma, Double Buffer, and Motion Filter.



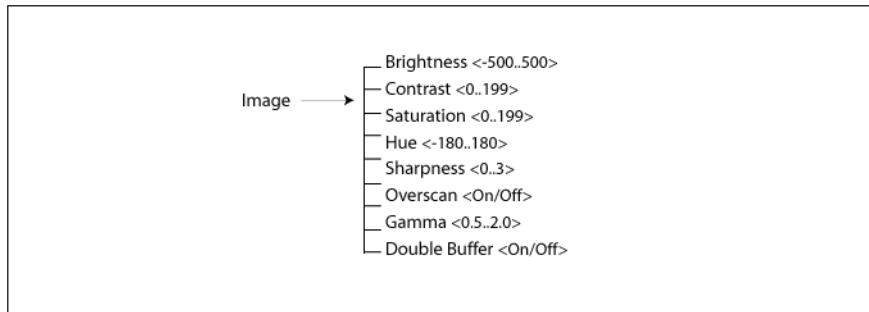

The currently active window (i.e. 3) is shown in parenthesis on the top line and the first three menu items and their current values are also shown. There is a prompt (>) which indicates the active menu item. Use the arrow keys to scroll through the menu items until the menu item you want is on the active line. All of the items in the IMAGE section work in the same way. Use the Left/Right arrow keys to step through the range of values for an active menu item. Once you have adjusted to the desired value, press ENTER to confirm and save the new value. Pressing ESCAPE or the Up/Down arrow keys will cancel changes.

To switch to another input to adjust, press one of the numbered buttons along the top left row. The new input number will appear in parenthesis in the LCD menu. Each menu item will also be updated to reflect the current values for the new window. This feature allows you to adjust parameters for ALL of your inputs with one button press. You can stay in the IMAGE menu until you have stepped through all of your inputs (1-12).

## INPUT MENU

Press the INPUT button to access this menu. It contains various timing adjustment menus as well as input type selection menus. The menus include Input Type, Load Input, Input Timing, Save Input Timing, Delete Input Timing, and Input Sync.

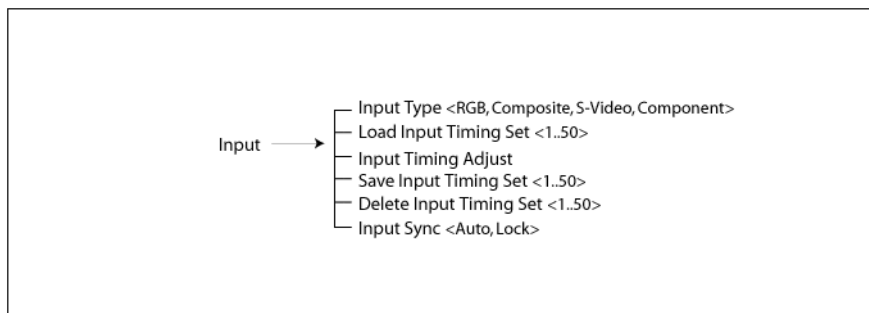

The currently active window (i.e. 3) is shown in parenthesis on the top line and the first three menu items and their current values are also shown. There is a prompt (>) which indicates the active menu item. Use the arrow keys to scroll through the menu items until the menu item you want is on the active line. With the exception of Input Timing Adjust, all of the items in the INPUT section work in the same way. Use the Left/Right arrow keys to step through the range of values for an active menu item. Once you have adjusted to the desired value, press ENTER to confirm and save the new value. Pressing ESCAPE or the Up/Down arrow keys will cancel changes.

The Input Timing Adjust menu is an interactive menu. This menu has no fixed values that you can step through one at a time. Press the ENTER button to enter the Interactive Timing Adjustment menu (the LCD will prompt you with instructions). Use the four arrow keys to make adjustments to the parameter. Press ENTER to confirm your changes or ESCAPE to cancel changes.

To switch to another input to adjust, press one of the numbered buttons along the top left row. The new input number will appear in parenthesis in the LCD menu. Each menu item will also be updated to reflect the current values for the new window. This feature allows you to adjust parameters for ALL of your inputs with one button press. You can stay in the INPUT menu until you have stepped through all of your inputs (1-12).

## OUTPUT MENU

Press the OUTPUT button to access this menu. It contains various adjustment menus for your output (or *host*) display, including setting your SuperView to either Auto or Free Run mode. The menus include Load Host, Output Timing Adjust, Save Host, Delete Host, Clear Host List, Horizontal Sync Polarity, Sync <3, 4, 5-wire>, Vertical Sync Polarity, Background, and Output Sync.

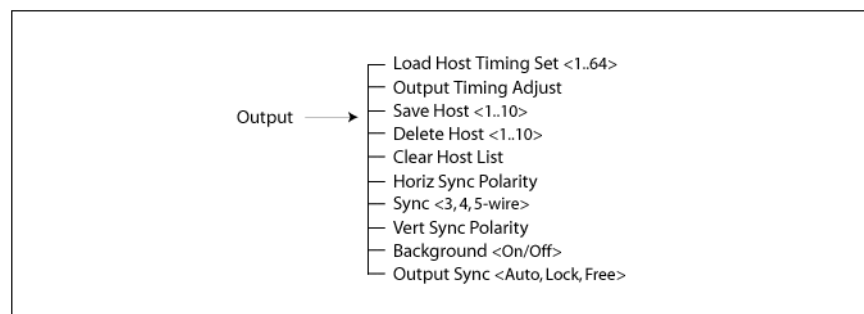

The top is the title line and the first three menu items and their current values are also shown. There is a prompt (>) which indicates the active menu item. Use the arrow keys to scroll through the menu items until the menu item you want is on the active line. With a few exceptions, the items in the OUTPUT section work in the same way. Use the Left/Right arrow keys to step through the range of

values for an active menu item. Once you have adjusted to the desired value, press ENTER to confirm and save the new value. Pressing ESCAPE or the Up/Down arrow keys will cancel changes.

Some of the menus in the Output section are interactive menus (i.e. Output Timing Adjust, Clear Host List). These menu have no fixed values that you can step through one at a time. Press the ENTER button to enter the interactive adjustment menu of these menus (the LCD will prompt you with instructions). Use the four arrow keys to make adjustments to the parameter. Press ENTER to confirm your changes or ESCAPE to cancel changes.

## WINDOW MENU

Press the WINDOW button to access this menu. It contains menus for adjusting, moving, and enabling all of your inputs. The menus include Window Enable, Size, Position, Zoom, Pan, and Priority.

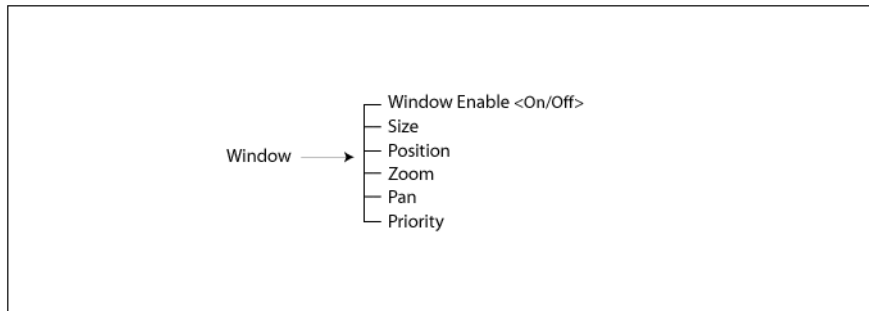

The currently active window (i.e. 3) is shown in parenthesis on the top line and the first three menu items and their current values are also shown. There is a prompt (>) which indicates the active menu item. With the exception of the Window Enable parameter, the WINDOW menus are all interactive menus. This means that the menu has no fixed values that you can step through one at a time. Press the ENTER button to enter the interactive adjustment menu for each parameter (the LCD will prompt you with instructions). Use the four arrow keys to make adjustments to the parameter. Press ENTER to confirm your changes or ESCAPE to cancel changes.

For the Window Enable menu, use the Left/Right arrows to toggle between the choices. Press ENTER to confirm the new value or press ESCAPE to cancel.

To switch to another input to adjust, press one of the numbered buttons along the top left row. The new input number will appear in parenthesis in the LCD menu. Each menu item will also be updated to reflect the current values for the new window. This feature allows you to adjust parameters for ALL of your inputs with one button press. You can stay in the WINDOW menu until you have stepped through all of your inputs (1-12).

## MISCELLANEOUS MENU

Press the MISCELLANEOUS button to access this menu. It contains menus for some overall system parameters. The menus include Test Pattern, Restore Factory Defaults, Auto Save, Save Configuration, Echo, Baud Rate, Chroma Key Enable, and Chroma Key Color.

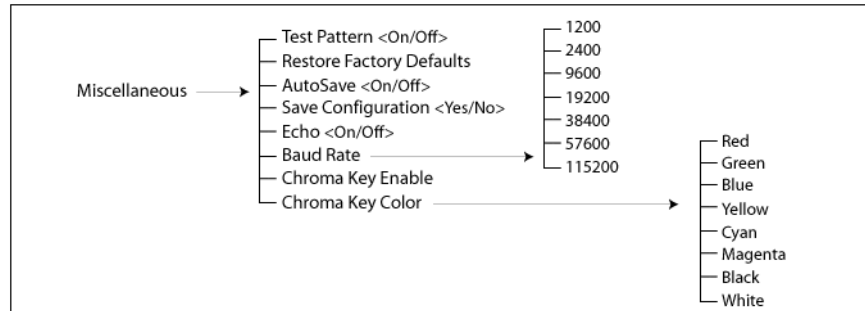

The currently active window (i.e. 3) is shown in parenthesis on the top line and the first three menu items and their current values are also shown. There is a prompt (>) which indicates the active menu item. All of the items in the MISCELLANEOUS section work in the same way. Use the Left/Right arrow keys to step through the range of values for an active menu item. Once you have adjusted to the desired value, press ENTER to confirm and save the new value. Pressing ESCAPE or the Up/Down arrow keys will cancel changes.

## STATUS MENU

Press the STATUS button to access this menu. This menu provides access to several menus that are *read-only*. These menus provide information about the current configuration of the SuperView. The menus include Firmware Version, Input Timing values, and Output Timing values.

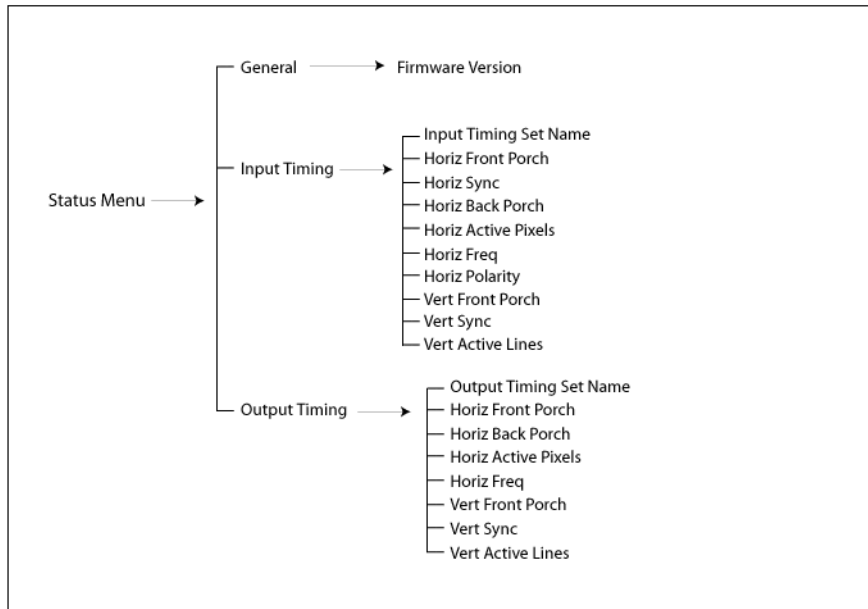

## PRESETS

The SuperView stores up to six user-defined presets. These presets store a specific screen configuration for the SuperView. This configuration includes window size, position, and order, image parameters, input timing parameters, and output timing parameters. The presets are not set with any factory defaults so they are all user-definable.

### SAVE A PRESET

To save a current configuration to a preset location, press the SAVE button followed by a numbered button. Note that once you press the SAVE button, the LCD will provide instructions on this procedure. Press ENTER to confirm the new preset and ESCAPE to cancel.

### RECALL A PRESET

To recall a user preset, press the RECALL button followed by the numbered button for the preset you want to load. Note that once you press the RECALL button, the LCD will provide instructions on this procedure. Press ENTER to confirm loading the specified preset and ESCAPE to cancel.



# SERIAL COMMAND SET

This section discusses the SuperView serial control commands. The command set provides access to all of the unit's functions.

An optional software control program, called the Virtual Control Panel (VCP), is also available. See "Control Software for Windows" on page 37 for more information on this program.

## GENERAL

The command set is made up of ASCII characters and is not case sensitive. The commands can be spelled out or abbreviated. For example, the **Brightness** command can be specified as **brightness**, **BRIGHTNESS**, **BRI**, or **bri**.

The entire serial command set for the SuperView is presented in this chapter.

Both forms of the command (long and short) are listed, as well as their associated parameters and descriptions. To execute serial instructions, each command line must be followed by a carriage return.

For example, at the prompt (>), a command would be as follows:

**bri 3 123**      Typing **bri 3 123** will change the brightness of input 3 to a new brightness value of 123.

Illegal commands or arguments generate error messages and correct usage instructions.

## SERIAL COMMAND SET USAGE

The serial command set can be used to control the SuperView. For example, to set the brightness level of input 1 to 123, type in **BRI 1 123**. The serial command set can also be used to find out the current state for a particular parameter. For example, to find out the brightness level of input 1, type **BRI 1**. The SuperView will return the current value (i.e. Brightness = 123).

The uppercase letters in the command name can be used to abbreviate the command on the prompt line. For example, **BRIghtness**, you can use **BRI**, and for **CONTRast**, you can use **CONT**. A space is required between a command and its argument. To execute serial commands, each command line must be followed by a carriage return.

The following tables list all of the commands for controlling the SuperView.

## INPUT COMMANDS

These commands allow you to make adjustments for your inputs and then save these settings into the unit's internal memory.

| Command          | Arguments   | Description  |
|------------------|---|--|
| INput            | <input #   ALL> [AUTO   LOCK   DEBUG]                           | Sets the input mode for the specified input. <i>Auto</i> engages the autosync circuitry. <i>Lock</i> turns the autosync circuitry off. <i>Debug</i> provides information on input status and reports changes to measured parameters.<br>Factory default: AUTO  |
| INputDELeTe      | <1...50>  | Deletes the specified saved input from the <i>Input List</i> .   |
| INputFormat      | <input #>   | <i>InputFormat</i> is a read-only command for checking the video format of the current video input selection. The command is only valid when <i>Input Type</i> is set to either Composite, Component, or S-Video. The response to the command will be NTSC or PAL.   |
| INputInteractive | <input#>  | Enters input interactive mode to visually adjust timing parameters of the specified input. A white box frame and cross hair appear over the full screen input.<br>Starting with the upper-left corner of the image, use these keyboard controls to position the image within the white frame:<br><b>i</b> = move up <b>m</b> = move down<br><b>j</b> = move left <b>I</b> = move right<br>With the upper-left corner properly adjusted, address the lower-right corner next by using these keyboard controls:<br><b>I</b> = move up <b>M</b> = move down<br><b>J</b> = move left <b>L</b> = move right<br>With the image properly adjusted, quit the utility:<br><b>q</b> = quit<br>After you have adjusted the input to your satisfaction, use the <i>Input Name</i> command to name your input source, and the <i>Input Save</i> command to store the setting to the <i>Input List</i> . |
| INputLIST        | [<1...50>] [<1...50>]<br>[<ACTIVE>]                             | Displays the entire <i>Input List</i> of saved input timings. If arguments are supplied, displays only the portion of the list requested. The <i>Active</i> argument displays all saved list entries.  |
| INputLOAD        | <input #> <1...50>  | Loads the indicated entry from the <i>Input List</i> to the specified input channel. The entry is loaded only if it matches the measured parameters of the signal—sync format and polarity, interlace state, vertical total, and horizontal frequency.   |
| INputName        | <input #> <name>  | Assigns a name to the specified input. The argument can be up to 17 alphanumeric characters with no spaces (underscore is acceptable).<br>Factory default: Auto_1  |
| INputSave        | <input#> <1...50>   | Saves the specified input to the selected entry in the <i>Input List</i> . These settings are recalled whenever the signal is reapplied to the SuperView.  |
| INputTiming      | <input #> <hfp> <hs> <hbp><br><hact> <vfp> <vs> <vbp><br><vact> | Sets the timing of the selected input.<br><b>Note:</b> The vertical total cannot be changed from the measured value; that is, the total of <vfp> + <vs> + <vbp> + <vact> must remain constant.<br>See Table 4 for acceptable ranges.   |



| Command       | Arguments   | Description  |
|---------------|---|--|
| INputTYPE     | <input#> <COMPOSITE   SVIDEO   COMPONENT   RGB>   | The command selects between the four possible inputs types for each channel. One input type per channel can be used at a time.<br>Factory default: RGB   |
| LoadInputList | <1...50> <name> <hfp> <hs> <hbp> <hact> <vfp> <vs> <vbp> <vact> <hfreq> <sync> <hpol> <vpol> <il> | The <i>LoadInputList</i> command lets you define input timing strings without requiring the input signal to be present. For example, if one SuperView system had an Input List which must be copied to a second unit, the LoadInputList command could be used to enter in the list entries one by one.<br><br>The first argument, <1...50>, indicates the Input List entry number to which to store the timing string. The second argument, <name>, gives a customized name to the signal. The next eight arguments, <hfp> <hs> <hbp> <hact> <vfp> <vs> <vbp> <vact>, define the signal's timing. The next five, <hfreq> <sync> <hpol> <vpol> <il>, define the horizontal frequency, sync format and polarity, and interlace status. All 15 arguments must be supplied for the command to be successful. |

## HOST COMMANDS

The Host commands control the output of the SuperView. They define the output or “host” timing and sync format, and save, load, and delete timings to the Host List.

| Command       | Arguments                    | Description  |
|---------------|------------------------------|--|
| ClearHostList | (none)                       | Clears the <i>Host List</i> of all user-defined hosts.   |
| HOST          | <AUTO   LOCK   FREE   DEBUG> | There are three host status settings and one setting used only for debug purposes. Host AUTO and host LOCK are used when there is a high-res input connected to the BACKGROUND INPUT connector on the SuperView.<br><br>For AUTO, the SuperView autosyncs to the background signal and uses the acquired host settings for the background.<br><br>For LOCK, the SuperView disables the autosync/host-matching circuitry. This option should only be used if the BACKGROUND INPUT signal is unstable in some respect.<br><br>The host FREE setting is used when you are running in free run mode and there is no background input connected.<br><br>The host DEBUG setting provides a detailed description of the mode of the internal sync generator and the measured characteristics of any applied high-res signal.<br>Factory default: FREE |
| HostDElete    | <1..10>                      | Deletes the specified user-defined host.   |

| Command         | Arguments   | Description  |
|-----------------|---|--|
| HostInteractive | (none)  | <p>Enters the host interactive mode. This is an adjustment mode for changing the Host Timing values to better suit your display device. Once in the interactive mode, a white box and cross hair appear on the output display.</p> <p>Starting with the upper-left corner of the box, use these keyboard controls:</p> <p><b>i</b> = move up    <b>m</b> = move down<br/> <b>j</b> = move left    <b>l</b> = move right</p> <p>With the upper-left corner properly adjusted, address the lower-right corner next by using these keyboard controls:</p> <p><b>I</b> = move up    <b>M</b> = move down<br/> <b>J</b> = move left    <b>L</b> = move right</p> <p>With the image properly adjusted, quit the utility:</p> <p><b>q</b> = quit</p> <p>After you have adjusted the input to your satisfaction, use the <i>Host Name</i> command to name your input source, and the <i>Host Save</i> command to store the <i>Host List</i>.</p> |
| HostLIST        | [<1...64>] [<1...64>]   | <p>Displays the entries in the Host List (Table 5). Without arguments, the command returns the entire list. With one argument, it returns information on the specified Host List entry. With both arguments, it returns the portion of the Host List specified by the arguments.</p> <p>The first 10 entries are user-defined. That is, these slots are reserved for host timing strings the user defines with the <i>HostTiming</i> and/or <i>HostInteractive</i> commands, and saves with the <i>HostSave</i> &lt;1...10&gt; command.</p> <p>Entries 11 through 54 include both progressive (non-interlaced) and interlaced hosts with a standard 4:3 or 5:4 aspect ratio. They are listed in order of decreasing resolution and frequency. Entries 55 through 63 are 16:9 wide screen hosts. Entry 64 is a 1600x1200 pixel host.</p> <p>Factory default: Host #11</p>   |
| HostLOAD        | <1...64>  | Loads the indicated host from the <i>Host List</i> .   |
| HostName        | <name>  | <p>Assigns a name to the current host. The argument can be up to 17 alphanumeric characters with no spaces (underscore is acceptable).</p> <p>Factory default: Auto_1</p>  |
| HostSave        | <1...10>  | Saves the current host settings into the <i>Host List</i> . The argument specifies which <i>Host List</i> position is used.  |
| HostTiming      | <input #> <hfp> <hs><br><hbp> <hact> <vfp> <vs><br><vbp> <vact> | <p>Sets the timing for the current host.</p> <p>Factory default: Host #11, 1280x1024, 75 Hz</p> <p>See Table 5 for a description of Host List.</p>   |

## WINDOW POSITIONING/VISIBILITY

This section contains commands for controlling the display configuration, zoom and pan operations, and freezing inputs.

| Command      | Arguments                 | Description  |
|--------------|---------------------------|--|
| BackGround   | <ON   OFF>                | This command is used if you are running the Autosync mode and have a high-res input connected to the BACKGROUND INPUT connector of the SuperView. This command allows you to turn the background window On or Off.<br>Factory default: ON  |
| DoubleBuffer | <input#> <ON   OFF>       | The double buffering feature eliminates pointer crossover. This is a visual artifact which can be visible in imagery containing horizontal motion—for example, a camera panning from left to right—or scene changes. It appears as a brief, horizontal break in the picture. Your eye may not discern it, but what you are seeing is a portion of one frame of video and a portion of another.<br><br>With DoubleBuffer ON, pointer crossover is eliminated. The trade off is that horizontal motion may appear a little jerkier. DoubleBuffer is applicable to both RGB and video inputs. When setting DoubleBuffer for input 1, first select the specific input type with the INputType command.<br><br>DoubleBuffer is only valid if the output host is progressive (non-interlaced), and if the input is an RGB signal, it must also be progressive. DoubleBuffer is also valid for all video inputs.<br>Factory default: ON |
| FreeZe       | <input#   ALL> <ON   OFF> | Turns freeze status of selected input on or off. If <i>Freeze</i> is on, it delays action of <i>Brightness</i> , <i>Contrast</i> , and <i>Gamma</i> commands until <i>Freeze</i> is turned off. The freeze status is maintained through switches between display configurations, as it is the input that is frozen, not the output. Any change to the host timing resets the freeze status to off.<br>Factory default: OFF   |
| OverScan     | <input #> <ON   OFF>      | <i>Overscan</i> performs an automatic 2% enlargement on video inputs only. It has no effect on WSR values, and it applies to all video inputs for the specified channel.<br><br><i>Overscan</i> is useful in trimming out excess blanking in video signals or head switching for VTR sources. Unlike WSR, when <i>Overscan</i> is turned on, the enlargement is automatic and constant even when switching between the various video input types.<br>Factory default: OFF  |
| PAN          | <input #>                 | Activates the pan utility for the selected input. Only a zoomed input can be panned.<br>The controls for the utility are as follows:<br><b>i</b> = pan up <b>m</b> = pan down<br><b>j</b> = pan left <b>l</b> = pan right<br><b>q</b> = quit   |

| Command  | Arguments                               | Description  |
|----------|---|--|
| POSition | <input #> [<direction><br><repetition>] | <p>Activates the position utility, allowing you to move the specified input around the output display. The controls for the utility are as follows:</p> <p><b>i</b> = move up    <b>m</b> = move down<br/> <b>j</b> = move left    <b>l</b> = move right    <b>q</b> = quit</p> <p>The <i>direction</i> and <i>repetition</i> arguments allow you to repeat a movement in one direction without repeatedly pressing the key. For example, to move window 1 to the left 20 times, you can type:</p> <p>&gt; POS 1 j 20</p> <p>The actual pixels or lines that a window moves is determined by the <i>Setrate</i> command. In the above example, the window will move 400 pixels to the left (20 times the default rate of 20 pixels).</p> <p><i>Position</i> affects the WDR value for the input.</p>   |
| PRIority | <input #   ALL> <1..12>                 | <p>Priority numbers run from one through the maximum number of inputs your SuperView has. Priority one is the highest priority level, meaning a window with priority one appears "in front of" all other windows.</p> <p>If a windows' priority is increased, the window previously at that priority level moves down one and, if necessary, lower priority windows also move down. In other words, no two inputs can have the same priority level.</p> <p>The <i>All</i> argument allows you to change the priority level for all inputs at once.</p>   |
| RSR      | <input #>                               | <p>Resets the source rectangle (WSR) to default value, that is equal to the HACT and VACT measurements of the specified input signal. RSR "unzooms" a zoomed image. RSR also resets brightness, contrast, gamma, hue, saturation, and sharpness values to defaults.</p>  |
| SETRATE  | <x-rate> <y-rate>                       | <p>This command determines the number of pixels (x-rate) or lines (y-rate) a window will move with the <i>Position</i> command.</p> <p>Factory default: x= 20, y= 20</p>   |
| SIZE     | <input #>                               | <p>Activates the size utility, allowing you to resize the specified input window. The controls for the utility are as follows:</p> <p><b>s</b> = smaller    <b>l</b> = larger<br/> <b>q</b> = quit</p> <p><i>Size</i> affects the WDR value for the input.</p>   |
| WDR      | <input #> <x> <y><br><width> <height>   | <p>This command sets both the position and size of an input's destination rectangle. The &lt;x&gt; and &lt;y&gt; arguments represent the monitor coordinates of the rectangle's top left corner, but hardware limitations may cause the actual placement to differ slightly from that specified. (When you read WDR for any window, the numbers given accurately reflect the state of the hardware.)</p> <p>The &lt;width&gt; and &lt;height&gt; arguments represent the pixel width and line height of the destination rectangle. The rectangle can be positioned and sized so that part of it is positioned off the screen. WDR is limited to the output resolution of the SuperView (full screen display).</p> <p>Example—with an output host resolution of 1024 x 768, set window 4 to be full screen:</p> <p>&gt;WDR 4 0 0 1024 768</p> <p>Example—place a 100 pixel by 100 line video window at column 300, line 400 on the monitor for input window 2:</p> <p>&gt;WDR 2 300 400 100 100</p> |

| Command  | Arguments                            | Description  |
|----------|--------------------------------------|--|
| WINDow   | <input#   ALL> <ON  OFF>             | <p>The <i>Window</i> command is used to turn off one or all inputs. If <i>Window</i> is Off and the input to that channel is removed and reapplied within two seconds then the status remains off. If <i>Window</i> is On and signal is removed for more than two seconds and then reapplied, the window status reverts to on. This allows for the use of a switcher and maintaining the desired on/off status. It also means that when a previously unused channel is used, the window automatically turns on allowing the new input to be displayed.</p> <p>The WIN ALL command is used to turn all windows on or off simultaneously.</p> <p>Factory default: ALL ON</p>   |
| WINDowID | <input #>                            | This command is used to identify a window. The specified input will flash on and off a few times on your output display.   |
| WSR      | <input#> <x> <y><br><width> <height> | <p>Sets the source rectangle for the selected input. The source rectangle is the portion of the original input that is displayed on screen. By default, WSR is set to show the entire image. That is, the default value for RGB inputs is equal to the HACT and VACT measurements of the specified input signal. For video, WSR defaults to 720x480 for NTSC and 720x574 for PAL.</p> <p>The source rectangle is used to zoom in or out on an image. The &lt;x&gt; and &lt;y&gt; coordinates represent coordinate screen starting point from which to draw the supplied values of &lt;width&gt; and &lt;height&gt;.</p> <p>Example—To zoom in on the upper left quadrant of an 800x600 input, the WSR values are:</p> <pre>wsr &lt;input#&gt; 0 0 400 300</pre> <p>To display only the bottom right quadrant, the WSR values are:</p> <pre>wsr &lt;input#&gt; 400 300 400 300</pre> <p>The full, default source rectangle for this 800x600 input is:</p> <pre>wsr &lt;input#&gt; 0 0 800 600</pre> <p>WSR resets to defaults whenever the signal is acquired or reacquired. That is, if you remove or replace the input signal, or if you change the input type selection on a single channel with the INPUTTYPE command, then WSR resets to the default values for the newly acquired signal.</p> |
| ZooM     | <input#>                             | <p>Activates the zoom utility. <i>Zoom</i> affects the WSR value for the input. The zoom utility controls are:</p> <p><b>i</b> = zoom in    <b>o</b> = zoom out</p> <p><b>q</b> = quit</p> <p>The maximum zoom is limited in all cases to no more than two times the original image. Not all inputs generate a 2x zoom ratio, however. The amount of available zoom range is dependent on the pixel rate of the input signal.</p> <p><i>Zoom</i> resets to an unzoomed state whenever the signal is acquired or reacquired. That is, if you remove or replace the input signal, or if you change the input type selection on a single channel with the <i>InputType</i> command, then <i>Zoom</i> resets to the default values for the new signal.</p>   |

## IMAGE CONTROLS

After you have made your adjustments with the *Input Commands*, you can then adjust the image controls for each input.

| Command        | Arguments   | Description   |
|----------------|---|---|
| BRiGht         | <input#   ALL> <-500...500>   | Sets <i>brightness</i> value of the selected input. The ALL argument sets brightness for all four inputs.<br>Factory default: 0   |
| ChromaKey      | <ON   OFF>  | Enables or disables chroma key mode. ChromaKey is not available in Free-run display mode. The effect of the chroma key is set with the ChromaKeyColor command.  |
| ChromaKeyColor | <-270...1250> <-270...1250><br><-270...1250> <-270...1250><br><-270...1250> <-270...1250> | This command sets the range of colors for the chroma key circuit. The chroma key works by replacing any color within the acceptance range by active video. The parameters are interpreted as follows: rmin rmax gmin gmax bmin bmax, representing the minimum and maximum values for red, green, and blue to fall within the acceptance range (see Appendix B for details). If a red, green, or blue color range is specified such that min > max, the command is ignored.<br><br>Example—make saturated cyan (full amplitude green and full amplitude blue with no red) the key color:<br>>CKC -270 100 600 1250 600 1250<br><br>The background host computer becomes transparent wherever a saturated cyan color is present; any underlying windows show through.<br><br>ChromaKeyColor can be set whether or not ChromaKey is enabled. |
| CONTrast       | <input#   ALL> <0...199>  | Sets <i>contrast</i> value of the selected input. The ALL argument sets contrast for all four inputs.<br>Factory default: 100   |
| GAMma          | <0.5...2.0>   | Sets a gamma value for the SuperView. For RGB inputs, the value is automatically saved with <i>InputSave</i> command.<br>Factory default: 1.0   |
| HUE            | <input#> <-180...180>   | Sets <i>hue</i> value of the selected input. Hue is only valid for video inputs.<br>Factory default: 0  |
| SATuration     | <input#> <0...199>  | Sets <i>saturation</i> value of the selected input. Saturation is only valid for video inputs.<br>Factory default: 100  |
| SHARPNess      | <input#> <0   1   2   3>  | Sets <i>sharpness</i> value of the selected input.<br>Factory default: 2  |

## SERIAL PORT FUNCTIONS

These commands control the baud and echo settings.

| Command  | Arguments   | Description  |
|----------|---|--|
| BAUDrate | <1200   2400   9600   19200   38400   57600   115200> | Sets the serial port <i>baud</i> rate. The value is automatically saved in NVRAM.<br>Factory default: 9600   |
| ECHO     | <ON   OFF>  | Turns the serial <i>echo</i> On/Off. The value is saved in the NVRAM. The <i>echo</i> is only on commands typed and sent to the unit.<br><b>Note:</b> <i>Echo</i> setting has no effect on responses issued by the SuperView; responses are always visible, regardless of the <i>echo</i> status.<br>Factory default: ON |

## MISCELLANEOUS

These commands control a variety of general SuperView functions.

| Command                | Arguments       | Description  |
|------------------------|-----------------|--|
| AUTOSAVE               | <ON   OFF>      | The <i>AutoSave</i> feature automatically stores the system configuration approximately every ten seconds. The process stores configuration information such as <i>HostList</i> , <i>InputList</i> , <i>Host</i> settings, and display parameters. <i>AutoSave</i> allows you to turn the NVRAM automatic update mode on or off.<br>Factory default: ON  |
| DEMO                   | (none)          | <i>Demo</i> runs the built-in demo sequence. Type “q” to quit demo.  |
| FrontPanel             | <ON   OFF>      | Enables and disables the front panel.<br>Factory default: ON   |
| Help                   | [<command>]     | <i>Help</i> , without an argument will display the entire serial command set. <i>Help</i> , with a command as an argument will display detailed information about that command.  |
| ID                     | (none)          | Displays the product identification, product name, firmware version number, date, and serial number.   |
| PRESET                 | <1...6>         | Stores your current screen configuration to the designated preset position. This configuration includes window size, position, and order, image parameters, input timing parameters, and output timing parameters. You can reload these presets using the <i>Recall</i> command.   |
| RECALL                 | <1...6> [<all>] | Recalls a previously saved preset configuration.<br>Without the ALL argument, the SuperView recalls only the position, size, and priority level for each input window.<br>With the ALL argument, the SuperView recalls all of the parameters stored in the EEPROM (i.e. input type selection, image controls, etc.). This option will take more time since more parameters are being recalled. |
| RestoreFactoryDefaults | (none)          | Restores all user settings to their factory default values.  |

| Command           | Arguments                                  | Description   |
|-------------------|--|---|
| SAVECONFIGuration | (none)                                     | Forces an update and explicit save of the system's NVRAM. This stores configuration information such as <i>HostList</i> , <i>InputList</i> , <i>Host</i> settings and display parameters.   |
| STATus            | (none)                                     | Returns the <i>Status</i> of the SuperView and its current settings.  |
| TestPattern       | <OFF   MovingBars   GrayScale   ColorBars> | This command turns the designated <i>TestPattern</i> (moving bars, grayscale, or color bars) on. Use the Off argument to turn the <i>TestPattern</i> off.<br>Factory default: OFF   |
| UpdateFirmWare    | (none)                                     | This command updates the firmware for the SuperView. If the baud rate is other than 115,200, the user will be prompted to change the baud rate of the terminal emulator and the SuperView to 115,200.<br>When this is complete, the <i>Updatefirmware</i> command must be re-issued and confirmed. The user is prompted to download the file.<br>On the screen, progress dots appear during the download.<br>See Appendix C for more information on the update procedure. |
| VERSION           | (none)                                     | <i>Version</i> returns firmware, hardware, and bootcode revision information.   |

TABLE 4. Definitions and Ranges for Input Timing Parameters

| Parameter | Definition                 | Range             |
|-----------|----------------------------|-------------------|
| HFP       | Horizontal front porch     | 0 to 640 pixels   |
| HS        | Horizontal sync            | 16 to 640 pixels  |
| HBP       | Horizontal back porch      | 0 to 640 pixels   |
| HACT      | Horizontal active          | 16 to 1600 pixels |
| VFP       | Vertical front porch       | 0 to 512 lines    |
| VS        | Vertical sync              | 2 to 32 lines     |
| VBP       | Vertical back porch        | 0 to 512 lines    |
| VACT      | Vertical active            | 12 to 1200 lines  |
| HFREQ     | Horizontal frequency in Hz | 15 to 90 kHz      |
| SYNC      | Sync format                | 3, 4, or 5 wires  |
| HPOL      | Horizontal sync polarity   | 1 or 0            |
| VPOL      | Vertical sync polarity     | 1 or 0            |
| IL        | Interlaced/Noninterlaced   | 1 or 0            |



TABLE 5. Host List

| #  | NAME                 | HFP | HS  | HBP | HACT | VFP | VS | VBP | VACT | HFREQ  | SYNC | HPOL | VPOL | IL |
|----|----------------------|-----|-----|-----|------|-----|----|-----|------|--------|------|------|------|----|
| 1  | (user defined hosts) |     |     |     |      |     |    |     |      |        |      |      |      |    |
| 10 |                      |     |     |     |      |     |    |     |      |        |      |      |      |    |
| 11 | VESA_1280x1024_75    | 16  | 144 | 248 | 1280 | 1   | 3  | 38  | 1024 | 799805 |      | 1    | 1    | 0  |
| 12 | VESA_1280x1024_60    | 48  | 112 | 248 | 1280 | 1   | 3  | 38  | 1024 | 639835 |      | 1    | 1    | 0  |
| 13 | 1280x1024_59.94      | 48  | 112 | 248 | 1280 | 1   | 3  | 38  | 1024 | 638975 |      | 1    | 1    | 0  |
| 14 | 1280x1024_50         | 52  | 116 | 250 | 1280 | 1   | 3  | 38  | 1024 | 532995 |      | 1    | 1    | 0  |
| 15 | VESA_1280x960_60     | 96  | 112 | 312 | 1280 | 1   | 3  | 36  | 960  | 600025 |      | 1    | 1    | 0  |
| 16 | 1280x960_59.94       | 96  | 112 | 312 | 1280 | 1   | 3  | 36  | 960  | 599415 |      | 1    | 1    | 0  |
| 17 | 1280x960_50          | 96  | 112 | 312 | 1280 | 1   | 3  | 36  | 960  | 500005 |      | 1    | 1    | 0  |
| 18 | EIA_1260x946_30      | 44  | 136 | 164 | 1260 | 8   | 8  | 61  | 473  | 306925 |      | 1    | 1    | 1  |
| 19 | EIA_1164x874_30      | 36  | 112 | 140 | 1164 | 6   | 6  | 59  | 437  | 283425 |      | 1    | 1    | 1  |
| 20 | SUN_1152x900_66      | 30  | 128 | 194 | 1152 | 2   | 4  | 31  | 900  | 617975 |      | 1    | 1    | 0  |
| 21 | APPLE_1152x870_75    | 32  | 128 | 144 | 1152 | 3   | 3  | 39  | 870  | 686815 |      | 1    | 1    | 0  |
| 22 | VESA_1152x864_75     | 64  | 128 | 256 | 1152 | 1   | 3  | 32  | 864  | 675035 |      | 1    | 1    | 0  |
| 23 | EIA_1080x809_30      | 26  | 96  | 118 | 1080 | 6   | 6  | 54  | 404  | 262445 |      | 1    | 1    | 1  |
| 24 | 1024x768_100         | 24  | 136 | 160 | 1024 | 3   | 6  | 29  | 768  | 806065 |      | 1    | 1    | 0  |
| 25 | VESA_1024x768_85     | 48  | 96  | 208 | 1024 | 1   | 3  | 36  | 768  | 686815 |      | 1    | 1    | 0  |
| 26 | VESA_1024x768_75     | 16  | 96  | 176 | 1024 | 1   | 3  | 28  | 768  | 600245 |      | 1    | 1    | 0  |
| 27 | VESA_1024x768_70     | 24  | 136 | 144 | 1024 | 3   | 6  | 29  | 768  | 564785 |      | 0    | 0    | 0  |
| 28 | VESA_1024x768_60     | 24  | 136 | 160 | 1024 | 3   | 6  | 29  | 768  | 483655 |      | 0    | 0    | 0  |
| 29 | 1024x768_59.94       | 24  | 134 | 158 | 1024 | 3   | 6  | 29  | 768  | 483115 |      | 0    | 0    | 0  |
| 30 | 1024x768_50          | 24  | 136 | 160 | 1024 | 3   | 6  | 29  | 768  | 403035 |      | 0    | 0    | 0  |
| 31 | VESA_1024x768_43     | 8   | 176 | 56  | 1024 | 0   | 8  | 41  | 384  | 356015 |      | 1    | 1    | 1  |
| 32 | EIA_900x674_30       | 20  | 64  | 80  | 900  | 5   | 5  | 45  | 337  | 218705 |      | 1    | 1    | 1  |
| 33 | APPLE_832x624_74     | 32  | 64  | 224 | 832  | 2   | 3  | 38  | 624  | 497165 |      | 1    | 1    | 0  |
| 34 | EIA_832x624_30       | 16  | 56  | 64  | 832  | 5   | 5  | 41  | 312  | 202535 |      | 1    | 1    | 1  |
| 35 | 800x600_100          | 32  | 96  | 128 | 800  | 1   | 2  | 22  | 600  | 625005 |      | 1    | 1    | 0  |
| 36 | VESA_800x600_85      | 32  | 64  | 152 | 800  | 1   | 3  | 27  | 600  | 536735 |      | 1    | 1    | 0  |
| 37 | VESA_800x600_75      | 16  | 80  | 160 | 800  | 1   | 3  | 21  | 600  | 468755 |      | 1    | 1    | 0  |
| 38 | VESA_800x600_72      | 56  | 120 | 64  | 800  | 37  | 6  | 23  | 600  | 480795 |      | 1    | 1    | 0  |
| 39 | VESA_800x600_60      | 40  | 128 | 88  | 800  | 1   | 4  | 23  | 600  | 378805 |      | 1    | 1    | 0  |
| 40 | 800x600_59.94        | 40  | 128 | 88  | 800  | 1   | 4  | 23  | 600  | 376425 |      | 1    | 1    | 0  |
| 41 | VESA_800x600_56      | 24  | 72  | 128 | 800  | 1   | 2  | 22  | 600  | 351565 |      | 1    | 1    | 0  |
| 42 | 800x600_50           | 32  | 96  | 128 | 800  | 1   | 2  | 22  | 600  | 312505 |      | 1    | 1    | 0  |
| 43 | PAL_768x576_25       | 22  | 70  | 84  | 768  | 5   | 5  | 39  | 288  | 156255 |      | 0    | 0    | 1  |
| 44 | 640x480_100          | 16  | 96  | 48  | 640  | 10  | 2  | 33  | 480  | 525015 |      | 0    | 0    | 0  |
| 45 | VESA_640x480_85      | 56  | 56  | 80  | 640  | 1   | 3  | 25  | 480  | 432695 |      | 0    | 0    | 0  |
| 46 | VESA_640x480_75      | 16  | 64  | 120 | 640  | 1   | 3  | 16  | 480  | 375005 |      | 0    | 0    | 0  |
| 47 | VESA_640x480_72      | 24  | 40  | 128 | 640  | 9   | 3  | 28  | 480  | 378605 |      | 0    | 0    | 0  |
| 48 | VESA_640x480_60      | 16  | 96  | 48  | 640  | 10  | 2  | 33  | 480  | 314735 |      | 0    | 0    | 0  |
| 49 | 640x480_59.94        | 16  | 96  | 48  | 640  | 10  | 2  | 33  | 480  | 314735 |      | 0    | 0    | 0  |
| 50 | 640x480_50           | 16  | 96  | 48  | 640  | 10  | 2  | 33  | 480  | 262505 |      | 0    | 0    | 0  |
| 51 | NTSC_640x480_30      | 44  | 112 | 104 | 1280 | 6   | 6  | 29  | 242  | 157345 |      | 0    | 0    | 1  |
| 52 | VESA_720x400_85      | 36  | 72  | 108 | 720  | 1   | 3  | 42  | 400  | 379275 |      | 0    | 1    | 0  |
| 53 | VESA_640x400_85      | 32  | 64  | 96  | 640  | 1   | 3  | 41  | 400  | 378605 |      | 0    | 1    | 0  |
| 54 | VESA_640x350_85      | 32  | 64  | 96  | 640  | 32  | 3  | 60  | 350  | 378605 |      | 1    | 0    | 0  |
| 55 | 1280x768_56          | 48  | 112 | 248 | 1280 | 1   | 3  | 30  | 768  | 451165 |      | 0    | 0    | 0  |
| 56 | 1280x720_100         | 110 | 40  | 220 | 1280 | 5   | 5  | 20  | 720  | 750015 |      | 0    | 0    | 0  |
| 57 | 1280x720_60          | 108 | 40  | 214 | 1280 | 5   | 5  | 20  | 720  | 450005 |      | 0    | 0    | 0  |
| 58 | 1280x720_59.94       | 112 | 40  | 224 | 1280 | 5   | 5  | 20  | 720  | 449555 |      | 0    | 0    | 0  |
| 59 | 1280x720_50          | 110 | 40  | 220 | 1280 | 5   | 5  | 20  | 720  | 375005 |      | 0    | 0    | 0  |
| 60 | 852x480_60           | 20  | 66  | 52  | 852  | 6   | 6  | 33  | 480  | 314915 |      | 0    | 0    | 0  |

|    |           |       |    |     |     |      |   |   |    |      |        |   |   |   |   |
|----|-----------|-------|----|-----|-----|------|---|---|----|------|--------|---|---|---|---|
| 61 | 852x480   | 59.94 | 20 | 66  | 52  | 852  | 6 | 6 | 33 | 480  | 314685 | 0 | 0 | 0 |   |
| 62 | 1360x1024 | 75.1  | 32 | 136 | 272 | 1360 | 3 | 3 | 35 | 1024 | 80000  | 5 | 1 | 1 | 0 |
| 63 | 1360x768  | 60    | 92 | 40  | 276 | 1360 | 3 | 6 | 18 | 768  | 47700  | 5 | 1 | 1 | 0 |
| 64 | 1600x1200 | 60    | 55 | 164 | 259 | 1365 | 1 | 3 | 46 | 1200 | 75001  | 5 | 1 | 1 | 0 |

## CONTROL SOFTWARE FOR WINDOWS

RGB Spectrum offers an optional software control program which runs under Microsoft Windows 95/98/2000/ME/XP/NT. The SuperView Virtual Control Panel (VCP) is a graphical user interface for RS-232 serial control.

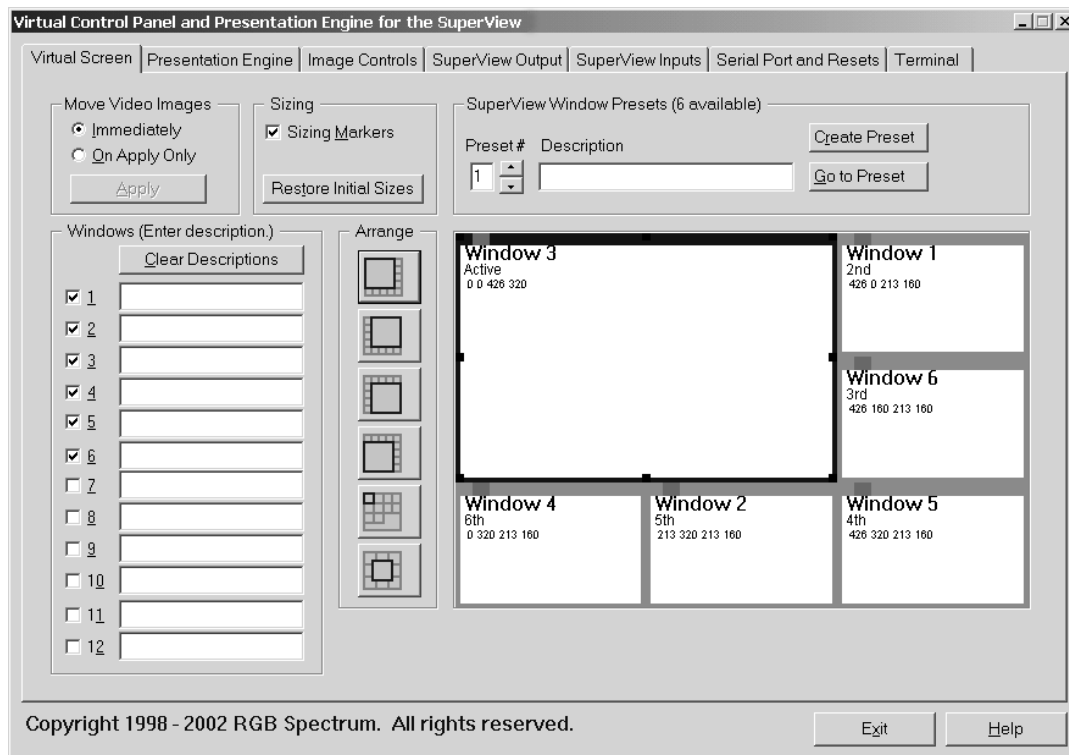

FIGURE 1. VCP Software for the SuperView 3000

With the VCP, you have push button control over all functions of the SuperView. The VCP requires the same serial connections as described in *Appendix A, "RS-232 Control"*.

The VCP comes with an online help feature, so the application is not covered in this User Manual. If you have purchased the VCP control software, please refer to the online help, accessible on each section of the software via the "Help" button located in the bottom right corner of the screen.

# TECHNICAL SPECIFICATIONS

## Input Signals (in windows)

|                             |  |
|-----------------------------|--|
| <b>Number</b>               | Up to 12 RGB/video channels  |
| <b>Type</b>                 | RGB: 640x480 to 1600x1200 pixels<br>Video: NTSC/PAL Composite, S-Video, Y PB PR Component                            |
| <b>Horizontal Scan Rate</b> | 15 kHz to 90 kHz interlaced or non-interlaced  |
| <b>Video Levels</b>         | 0.7 V to 1.0 V   |
| <b>Sync Type</b>            | Sync on green, separate composite sync, or separate H-Drive and V-Drive  |
| <b>Connectors</b>           | RGB/Component: 15-pin HD D-Sub (female)<br>Composite: BNC (female)<br>S-Video: 4-pin mini DIN (female)               |
| <b>Image Controls</b>       | Position, scaling, freeze, pan and zoom, brightness, contrast, saturation, hue, gamma, chroma key, and motion filter |

## Input Signal (in background)

|                             |   |
|-----------------------------|---|
| <b>Horizontal Scan Rate</b> | 15 kHz to 100 kHz interlaced or non-interlaced                          |
| <b>Resolution</b>           | 640x480 to 1600x1200 pixels   |
| <b>Video Levels</b>         | 0.7 V to 1.0 V  |
| <b>Sync Type</b>            | Sync on green, separate composite sync, or separate H-Drive and V-Drive |
| <b>Connector</b>            | 15-pin HD D-Sub (female)  |

## Output Signal

|                                  |   |
|----------------------------------|---|
| <b>Genlock Mode</b>              | Locked to an external signal  |
| <b>Background Mode</b>           | Locked to an external signal that is displayed in the background    |
| <b>Free Run Mode</b>             | User configurable internally generated sync                         |
| <b>Analog Output Resolution</b>  | Same as above, up to 1600x1200 pixels                               |
| <b>Digital Output Resolution</b> | DVI, up to 1280x1024 pixels<br>(for Free Run and Genlock mode only) |

## Other

|                        |  |
|------------------------|--|
| <b>User Interfaces</b> | - (2) RS-232 serial ports<br>- Front Panel (optional)<br>- Virtual Control Panel software (optional) |
| <b>Power</b>           | 100-264 VAC, 47-63 Hz<br>Less than 100 Watts   |

|               |  |
|---------------|--|
| <b>Size</b>   | 2RU (up to six inputs): Width 17.5" (44.5 cm)<br>Depth 18.0" (45.7 cm)<br>Height 3.5" (8.9 cm)<br><br>3RU (up to twelve inputs): Width 17.5" (44.5 cm)<br>Depth 18.0" (45.7 cm)<br>Height 5.3" (13.3 cm) |
| <b>Weight</b> | Approximately 22 lbs (10 kg)   |

# TROUBLESHOOTING

Problems with the SuperView's operation may result from inappropriate system connections and settings. In the event of difficulty or anomalous results, first check cable connections, the video format associated with each input, the monitor timing selected, and any system options currently in effect. Some of these are discussed in Table 6. Please note that the SuperView's hardware should only be modified or repaired by RGB Spectrum's technicians.

## TROUBLESHOOTING GUIDE

TABLE 6. Troubleshooting Guide

| Symptom   | Recommendations   |
|---|---|
| No Power or Lights  | Check that the SuperView is plugged in and powered on. Check the fuse located in the line filter. Remove the fuse cover from the power connector panel. The unit is supplied with two fuses; the second one is a spare. If the primary fuse appears blown, replace it with the spare.   |
| No Signal/Poor Signal on Monitor for Computer Input                                   | Verify display mode (HOST FREE or HOST AUTO).<br>Free-run mode: Make sure a suitable host is loaded from the Host List.<br>Autosync mode: Check cable connections from the host computer to the SuperView's BACKGROUND INPUT, and from the SuperView's ANALOG OUTPUT to the monitor. Ensure that the same number of coaxial cables are attached on both the input and the output side of the SuperView. |
| No Windows  | Ensure that at least one window is enabled. Ensure that the chroma key is correctly configured. (If the ChromaKey is enabled, switch it off. If the window appears in the key color area, you have a ChromaKeyColor setting which is inconsistent with your reserved color.)  |
| Background Computer Graphics Rolls Vertically   | Check cables connections from the host computer to the SuperView and from the SuperView to the display device. Check if the problem persists when the monitor is connected directly to the host computer's output.  |
| Windows have wrong aspect ratio (i.e., are stretched) or are not positioned correctly | Use the HostInteractive command to adjust timing parameter values. Verify that the window source rectangle (WSR) and window destination rectangle (WDR) have the same aspect ratio (for serial control) or that AspectRatioTrim is set to 1000 (for front panel control).   |
| Blank Video Window (window is black)  | Ensure that the window's video source is properly connected to the system, powered on and generating a signal. Ensure that the correct type is selected (Composite, Component, or S-Video) with the INputTYPE command.  |
| Frozen Window(s)  | If a window is frozen after system start-up, turn freeze off. Use the FreeZe OFF command.   |
| Missing Window Imagery  | Check the WSR value to ensure the entire image is being processed. Check WSR and WDR to ensure the source and destination rectangles are delivering the entire video image. Verify that ChromaKey is off.<br>From the front panel, use the size, priority, zoom and position controls to ensure the entire image is properly sized and positioned on the screen.  |

| Symptom   | Recommendations  |
|---|--|
| Poor Quality Video  | Check the video source for proper operation. Ensure that video sources are not doubly terminated. (Double termination can occur when one video source is split into two using a "T" connector instead of a distribution amplifier.) If you are using a VCR, check the quality of the tape. Adjust the brightness and contrast controls. If you are using the chroma key function, see below.   |
| Poor Quality in Chroma Key Mode                                 | Check that the chroma key is correctly set up. See Appendix B, "Video Levels and Chroma Key,". Chroma keying is best accomplished on solid colors. Do not key on dithered backgrounds, such as crosshatching and dot patterns. Note that some computer graphics software uses dithering to obtain certain colors or gray values. Also, keying video in over a color-ramped background (consisting of a series of graduated shades) may produce an inconsistent, speckled result in the region where the ramp shades closely approximate the limits of the key color range. |
| Motion Blur on Frozen or Live Video with Fast Moving Imagery    | Turn the motion filter on. From the front panel, navigate to the Motion Filter menu and turn it Off. Otherwise, use the MotionFilter serial command.   |
| No Text on a terminal   | Enable the echo mode when using an ASCII terminal or terminal emulation program to control the system from the RS-232 port, if you wish to see your own typed entries. Use the ECHO command to enable or disable the echo mode.<br><br>When using an application program running on a computer to control the SuperView's functions over the RS-232 port, you may need to disable the echo mode.   |
| Unreliable Control of the SuperView from a computer application | See the recommendation immediately above. You may need to disable echo.<br><br>Check that the baud rate for the SuperView and your console device are set to the same speed. You can set the SuperView to a 9600 baud rate from the front panel Miscellaneous menu. Set your serial console to a matching baud rate and communications should be established. See <i>Appendix A</i> .  |

## HOW TO CONTACT RGB SPECTRUM

RGB Spectrum can be reached via phone, fax, mail and e-mail:

RGB Spectrum  
 950 Marina Village Parkway  
 Alameda, CA 94501  
 Phone: (510) 814-7000  
 Fax: (510) 814-7026  
 E-Mail: support@rgb.com (*for technical support*)  
 sales@rgb.com (*for sales and product info*)  
 Website: http://www.rgb.com

## FIRMWARE UPDATES/README FILES

Please visit our website (www.rgb.com) for product, technical, sales and other company information.

The system firmware can be updated in the field. On our website, under the "Support" section, you will find any available firmware updates (see Appendix

C for details) and README files, offering late-breaking technical information on our products.







# RS-232 CONTROL

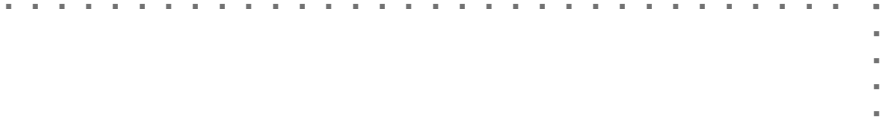

The SuperView has two RS-232 serial communications ports for remote control of its functions, enabling the SuperView to receive data and instructions from host applications, and to be explicitly controlled with commands sent via the serial port from a computer (or ASCII terminal). This port is configured according to the Electronic Industries Association Standard RS-232-C published in August 1969.

Physically, the RS-232 ports are 9-pin D-Sub female connector.

## CONNECTING THE RS-232 PORT

The SuperView can be explicitly controlled with ASCII Command Set instructions sent via the Primary RS-232 serial port from either a computer or an ASCII terminal. See Chapter 6 for details of the Command Set.

The Auxiliary serial communications port is provided to implement daisy-chaining of multiple systems. The Auxiliary port of an upstream unit is connected to the Primary port of a downstream unit (Figure 11). When a unit is not selected, it passes all commands to its downstream port, and passes all responses from its Auxiliary port back to the console. See Appendix D, “Serial Control of Multiple Units.”

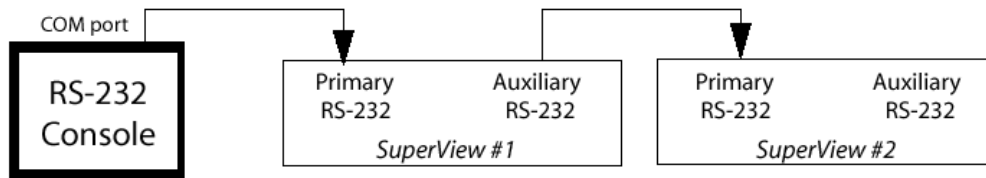

FIGURE 11. Serial Control of Two SuperViews

Determine whether the computer’s serial port has a 9-pin D-Sub or 25-pin D-Sub connector. Use a 9-pin to 9-pin serial cable to connect the SuperView’s serial port to that of the computer (with a 9-pin to 25-pin adapter to complete the connection if necessary).

When controlled from an ASCII terminal, the SuperView must echo characters as they are typed—this enables you to see characters as you enter them. However, if you are using a serial port on a UNIX workstation, the “echo” option must be disabled to ensure correct operation. Selection of “echo” or “no

echo” is made with the **ECHO** command. If the SuperView is connected to a computer configured as Data Communications Equipment (D.C.E.), you need to use a null modem. See “The Null Modem” on page 48.

Almost all ASCII terminals, and most computer serial ports, are configured as D.T.E. To connect these to SuperView, you need a “straight-through” cable with pins 1 through 8 connected. “Straight-through” implies that pin 1 is connected to pin 1, pin 2 to pin 2, and so on (Figure 12). The cable will have a 9-pin male plug on SuperView’s end, and the appropriate gender of a 9-pin connector on the other end. Most ASCII terminals and host computers have a 9-pin female connector for their RS-232 port.

The serial cable can be up to 50 feet long for regular cable, or substantially longer for low capacitance cable. Depending on the signals used, one or more of the conductors internal to the cable may not be needed.

#### PINOUT DESCRIPTION

The 9-pin D-Sub connector is configured as Data Communications Equipment (D.C.E.) with the following signals:

TABLE 7. RS-232 Serial Port Pinout

| D-Sub 9-pin | Circuit | Description                   |
|-------------|---------|-------------------------------|
| 1           | CD      | Carrier Detect                |
| 2           | TD      | Transmit Data                 |
| 3           | RD      | Received Data                 |
| 4           |         | (not connected)               |
| 5           | AB      | Signal Ground (common return) |
| 6           | DSR     | Data Set Ready                |
| 7           | CTS     | Clear to Send                 |
| 8           | RTS     | Request to Send               |
| 9           |         | (not connected)               |

As seen in Figure 12, the pins are numbered from top to bottom, right to left. So, looking at the connector, pin #1 is located in the upper right corner, and pin #9 is in the lower left corner.

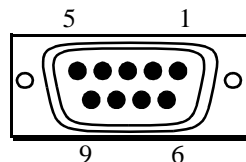

FIGURE 12. 9-pin D-Sub RS-232 Female Connector

RS-232  
PARAMETERS

Ensure that your device is set up with these default serial port parameters.

TABLE 8. RS-232 Parameters

|                |                                |
|----------------|--------------------------------|
| Duplex:        | Full                           |
| Baud rate:     | 9600 (default setting)         |
| Data bits:     | 8                              |
| Start bit:     | 1                              |
| Stop bit:      | 1                              |
| Parity:        | no parity                      |
| Physical:      | 9-pin D-Sub connector (female) |
| Configuration: | D.C.E.                         |
| Handshake:     | X-On / X-Off                   |

Ensure that the controlling host computer or ASCII terminal is set for 9600 baud, 8 data bits, 1 start bit, 1 stop bit and no parity. These are the default serial port parameters. The baud rate and handshake settings can be changed.

Ensure that the Echo/No Echo mode is set appropriately. Transmitted Data is considered an input, and Received Data is considered an output because these signals are named from the perspective of the Data Terminal Equipment (D.T.E.) to which the D.C.E. will normally be connected. Transmitted Data is the signal which communicates commands from the host computer RS-232 port, or the ASCII terminal, to the SuperView. Received Data is the signal that returns status, parameter values and, if the SuperView is being controlled by an ASCII terminal, echoes the commands.

**Request to Send** is a handshaking signal generated by the Data Terminal Equipment. It is always asserted.

**Clear to Send** is a signal generated by the Data Communications Equipment in response to the Data Terminal Equipment's assertion of **Request to Send**. It indicates that the Data Communication Equipment has recognized the **Request to Send** and is not busy (i.e. it is ready to receive data). **Clear to Send** is always asserted.

**Data Set Ready** is a signal generated by the Data Communications Equipment, normally to indicate it has power. It is used by the Data Terminal Equipment to verify that the cable is connected, that there is Data Communications Equipment on the other end of the cable and that the equipment is switched on. **Data Set Ready** is always asserted.

**Received Line Signal Detector** (sometimes known as **Data Carrier Detect**) is a signal generated by the Data Communications Equipment. **Received Line Signal Detector** is always asserted.

Almost all ASCII terminals, and most computer serial ports, are configured as Data Terminal Equipment. To connect these to the SuperView, you need a “straight through” cable with pins 1 through 8 connected. “Straight through” implies that pin 2 is connected to pin 2, etc. The cable will have a 9-pin male plug on SuperView’s end, and the appropriate gender of a 9-pin connector on the other end. Most ASCII terminals and host computers have a 9-pin female connector for their RS-232 port. This cable may be up to 50 feet long for regular cable, or substantially longer for low capacitance cable. Depending on the signals used, one or more of the conductors internal to the cable may not be needed.

**THE NULL****MODEM**  
.....

You may need to connect the SuperView’s serial port to a host computer configured as Data Communications Equipment. This is done using a null modem. The net effect of a null modem is to reverse the Transmitted Data and Received Data connections. Also, the Request to Send and Clear to Send connections are reversed. This may be done by using a special “null modem” cable, or by inserting a small “null modem” box or cable in series with a regular “straight through” cable.

## VIDEO LEVELS AND CHROMA KEY

---

If you have the optional **BACKGROUND INPUT** connector on your SuperView unit, then in Autosync mode you have the option of using the Chroma Key mode. In this Autosync display option, windows *selectively* replace the background computer graphics, based on the color of the graphics. The concept of chroma key is discussed in greater detail in this chapter.

The SuperView's chroma key serves two purposes. First, it allows the boundaries of the video window to be user-defined. You can create windows of arbitrary shape by "painting" a window of the desired shape in the key color. The second purpose is to overlay the video with the host computer's graphics and text. The host computer graphics and text are generated on the computer screen in the same area as the window. A key color for the background of the host computer graphics image is selected. This key color must be different from any other color used in the computer graphics overlay. When the **ChromaKey** is enabled, the window is displayed in the background of the host computer image—i.e., the graphic overlays block out the window image, and the window image appears where the key color is drawn.

The key color is defined by a range of values for each of the red, green, and blue computer signals. The selected key defines whether the host computer's display signal is "transparent", i.e., if the color from the computer falls within the specified range, the window signal is shown. For example, if a host computer signal consists of red lines on a white background, and white is chosen as the key color, then the resultant image on the screen is of the window overlaid by the red lines. Considering it another way, you could say that the window "shows through" the white area.

The SuperView's chroma key circuitry works by examining the values of the host computer's red, green, and blue signals at every point on the screen. If the value of each signal falls in the "acceptance range" for that signal, the host computer image is made transparent, and the windows are allowed to show through. All three high-resolution signals (red, green, and blue) must lie simultaneously within their respective acceptance ranges for the host computer image to be transparent. For the windows to be made visible, the chroma key circuitry must indicate that the host signals are within the acceptance range, at the same region as the window location.

It is not possible to key on a single color value. This is because the precision of the digital representation of the color in the host computer's frame buffer (or color map) is lost when it is converted into analog form in order to drive the color monitor. There is also variation in gain from frame buffer to frame buffer. Even if it were possible to specify the color exactly, slight amounts of noise, video overshoot and temperature drift would cause unreliability. Therefore, you must specify a range of colors on which to key.

Most users will use one of the six full amplitude saturated colors, or black or white, for the key color. (See **Table xx**).

**TABLE 9. ChromaKeyColor Values—Saturated Colors**

| Color   | Red  | Green | Blue | ChromaKeyColor             |
|---------|------|-------|------|----------------------------|
| White   | 100% | 100%  | 100% | 525 1250 525 1250 525 1250 |
| Yellow  | 100% | 100%  | 0%   | 525 1250 525 1250 -270 175 |
| Cyan    | 0%   | 100%  | 100% | -270 175 525 1250 525 1250 |
| Green   | 0%   | 100%  | 0%   | -270 175 525 1250 -270 175 |
| Magenta | 100% | 0%    | 100% | 525 1250 -270 175 525 1250 |
| Red     | 100% | 0%    | 0%   | 525 1250 -270 175 -270 175 |
| Blue    | 0%   | 0%    | 100% | -270 175 -270 175 525 1250 |
| Black   | 0%   | 0%    | 0%   | -270 175 -270 175 -270 175 |

The situation is more complex if you wish to key on a color other than a full amplitude saturated color, or if your host computer outputs non-standard signal levels. You must then understand how chroma key levels are handled by the system.

The chroma key circuitry in the SuperView is designed to operate with a variety of frame buffer output levels. The key color acceptance range you specify may not be centered on the color value you wrote to the host computer frame buffer (see the following discussion).

high-resolution frame buffers generally output video which falls into one of three different voltage ranges depending on the design. These voltage ranges are:

- 0.700 Volt p-p (black level of 0 V)
- 0.714 Volt p-p (black level of 54 mV)
- 1.000 Volt p-p (black level of 0 V)

Probably 98% of computers fall into the first two categories. The voltage levels are sufficiently close that, in most cases, the same key range will work for both. Only the peak-to-peak video amplitude is of concern; the SuperView contains circuitry to cancel any DC offsets. The upper and lower thresholds for the chroma key are determined by eight bit digital-to-analog converters. The converters output a voltage in the range -270 mV to +1250 mV.

Consider a computer frame buffer with a 700 mV output voltage range. We want to key on full amplitude saturated cyan, i.e. no red, full amplitude green and full amplitude blue. To accomplish this, let's choose ranges such that we are looking for a red value less than 25% of maximum, and green and blue values which are greater than 75% of maximum. These may appear to be relatively large ranges, but they reserve only 1.6% of the available color gamut for the

chroma key. This is because the frame buffer color must lie within the correct range for all three color components simultaneously. The fraction of all colors reserved for the chroma key is the product of the individual fractions. For the example given, this is equal to  $0.25 \times 0.25 \times 0.25 = 0.016 = 1.6\%$ .

We calculate that the low threshold is 175 (25% of 700 mV) and the high threshold is 525 (75% of 700 mV). Using the **ChromaKeyColor** command, we issue the command:

```
>ckc -270 175 525 1250 525 1250
```

Look for a red level less than 175 mV by specifying a red level between -270 (the minimum level the hardware understands) and 175. Similarly, look for green and blue levels greater than 525 mV by specifying green and blue levels between 525 and 1250 (the maximum level the hardware understands).

The above procedure should work reasonably for computer frame buffers with voltage ranges of 714 mV and 1 V as well. A 700 mV will have a slightly smaller margin at the low voltage (black) end, and a 1 V buffer will have a substantially larger margin at the high voltage (white) end.







# UPDATING SYSTEM FIRMWARE

---

The firmware version in the SuperView can be field updated via the RS-232 serial port. The firmware is like the operating system in your computer—it instructs the SuperView in all of its operations.



Required for the procedure:

1. Computer or terminal capable of serial communications at a 115,200 baud rate;
2. Current firmware update file and update instructions

**Do not proceed to update firmware without these two items!**

If a firmware update has been published, the file can be downloaded from the RGB Spectrum website at <http://www.rgb.com>, in the Support section. The firmware would also be available on disk directly from RGB Spectrum. Instructions and release notes accompany the update file.

Note: The update firmware process cannot be used from within the SuperView VCP control software. You must use a terminal emulation program—such as HyperTerminal or Procomm—or a dumb terminal capable of communicating at 115,200 bps.

After the firmware update procedure is complete, the system is restored to factory defaults. The baudrate is set to 9600 bps and all data previously stored to the EEPROM is erased.



## SERIAL CONTROL OF MULTIPLE UNITS

The Multi-Product Serial Driver (MPSD) is a protocol for controlling more than one RGB Spectrum product through a single console. The maximum number of MPSD supported products in a single chain is ten. An extra non-MPSD supported device can be connected to the last MPSD device in the chain, making the total controllable devices equal to eleven.

The Auxiliary serial communications port is used to implement daisy-chaining of multiple systems. The Auxiliary port of an upstream device is connected to the primary port of a downstream device (see Figure 13). When a device is not selected, it passes all commands to its downstream port, and passes all responses from its Auxiliary port back to the console.

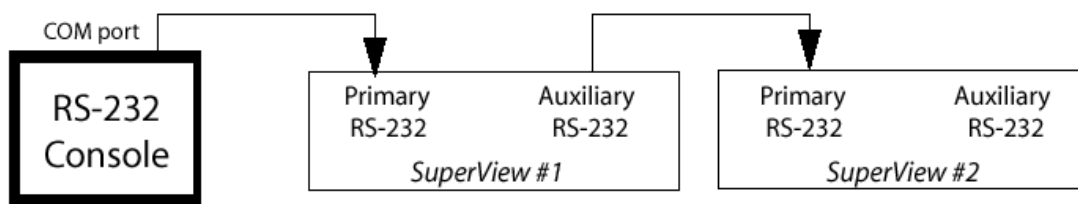

FIGURE 13. Serial Control of Two SuperView Units

### MPSD COMMANDS

All MPSD commands are preceded with ":" and are buffered by each device that receives them. The devices must be placed in MPSD mode with the **:assign** command before any other MPSD commands can be issued.

If the console receives no response from the devices, or a wrong command is issued, entering **:assign** usually brings the system back into communication.

**:assign** - identifies all connected devices and enters into MPSD mode

```
:assign
```

This command identifies all connected devices and places them in MPSD mode. Each device has a unique ID number from 0 to 9. Device 0 is automatically selected to communicate with the terminal console. The ID number or device name is shown with the prompt sign so users can recognize

which device they are working with. Since all MPSD commands are buffered, Device 0 is responsible for echoing MPSD commands to the console.

**:unassign - cancels MPSD mode for all connected devices**

```
:unassign
```

This command removes all connected devices from MPSD mode. Device 0 then communicates with the console as a stand-alone device.

**:select - selects a particular device to communicate with**

```
:select <device number|device name>
```

Selects a particular device to communicate with the console. Other devices which do not match the device number or device name are deselected. If a non-valid number or name is entered, the console cannot receive any responses to commands or queries because none of the devices is selected. Entering the **:select** command with a valid argument re-establishes communication with the console.

If a non-MPSD device is connected to the end of the chain and a non-valid device number or name is entered, the non-MPSD device is selected. However, if the intent is to control a non-MPSD device in a chain of devices, use the **:auxdevice** command.

**:auxdevice - select a non-MPSD device**

```
:auxdevice
```

To send serial commands to a non-MPSD device installed at the end of the MPSD chain, use the **:auxdevice** command. If no such device is connected, the console will not receive any response. When the non-MPSD device is selected, an error message in response to the initial MPSD command may be shown on the console because the non-MPSD device cannot recognize it.

To re-establish communication with the MPSD devices, use either the **:assign** or **:select** command.

**:addname - assign a name to a particular device**

```
:addname <device number> [<device name>]
```

This command allows you to assign a name to an MPSD device. The name is permanently stored in the SuperView's memory. The device can be connected to different positions on the chain and the device's name remains attached to it.

If the [**device name**] argument is not entered, the name of the selected device is deleted.

*Example*—assign the name “Screen2” to the second SuperView in the MPSD chain:

```
Device 0> :addname 1 Screen2
```

**:report - check the identity of one or all MPSD device(s) in the chain**

```
:report <device number | device name>
```

Reports the identification of one or all MPSD device(s) in the chain.

If the command is entered without argument, all MPSD devices respond by sending a single line of device information to the console. If a device number or device name follows the command, that particular device responds to the console with its identifying information.

## MPSD EXAMPLE: BAUD RATE CHANGE

In this example of changing the baud rate by MPSD control, the first step is to place all of the five connected devices in MPSD mode. Next, the baud rate is changed from 9600 (default) to 115200 for each of the five MPSD devices. Then, the baud rate of the terminal console is changed to 115200. Keep in mind that Device 0 is automatically selected to communicate with the terminal console when in MPSD mode. Device 0 is responsible for echoing and relaying MPSD commands. When out of MPSD mode, Device 0 is communicating with the terminal console as a stand-alone unit.

### STEP ONE

```
> :assign                                identify all connected devices and enter them
                                         into MPSD mode
```

### STEP TWO

```
Device 0> :select 4                       select Device 4 to receive commands
Device 4> baudrate 115200                 set baud rate of Device 4 to 115200
> :select 3                               select Device 3 to receive command
Device 3> baudrate 115200                 set baud rate of Device 3 to 115200
> :select 2                               select Device 2 to receive command
Device 2> baudrate 115200                 set baud rate of Device 2 to 115200
> :select 1                               select device 1 to receive command
Device 1> baudrate 115200                 set baud rate of Device 1 to 115200
> :select 0                               select Device 0 to receive command
Device 0> baudrate 115200                 set baud rate of Device 0 to 115200
```

### STEP THREE

The baud rate on the console can now be changed to 115200, and then:

```
> :unassign                               disengage MPSD mode and clear out serial buffer
> :assign                                  re-establish MPSD communication mode
Device 0>
```

The baud rate is changed starting from the last device in the chain because after the baud rate is set, there will be no communication between that device and the console. Even though there is no prompt sign returned to the console, we still

can enter MPSD commands. Selecting the next upstream device in the chain, which is still at the old baud rate, re-establishes communication.

After changing the baud rate for the console, the **:unassign** command is issued to clear out the serial buffer before re-establishing communication once again with Device 0.



# PRODUCT WARRANTY



## WARRANTY

RGB Spectrum (RGB) warrants that this product will be free from defects in material and workmanship, under normal use and service when correctly installed and maintained, for a period of one (1) year from date of shipment. RGB's liability under this warranty is limited solely to replacing, repairing or issuing credit for any product which is shown to be defective during the warranty period. Purchaser shall (i) notify RGB promptly in writing of any claims, and (ii) provide RGB with an opportunity to inspect and test the product claimed to be defective. Warranty does not cover misuse, abuse, improper installation or application, improper maintenance or repair, alteration, accident or negligence in use, improper temperature, humidity or other environmental condition, storage, transportation or handling. RGB shall have no obligations under this warranty with respect to any defect unless it receives notice and a description of such defect no later than five (5) business days following the expiration of the warranty period.

THE WARRANTIES STATED HEREIN ARE IN LIEU OF ALL OTHER WARRANTIES, EXPRESS OR IMPLIED, INCLUDING (BUT NOT LIMITED TO) ANY IMPLIED WARRANTIES OF MERCHANTABILITY OR FITNESS FOR A PARTICULAR PURPOSE.

IN NO EVENT SHALL RGB BE LIABLE FOR ANY SPECIAL, INCIDENTAL OR CONSEQUENTIAL DAMAGES FOR LOSS, DAMAGE OR EXPENSE DIRECTLY OR INDIRECTLY ARISING FROM THE PURCHASER'S INABILITY TO USE THE PRODUCT EITHER SEPARATELY OR IN COMBINATION WITH ANY OTHER EQUIPMENT OR FACILITIES, OR FROM ANY OTHER CAUSE.

## EXTENDED WARRANTY

An annual extended warranty may be purchased. Should the product fail to operate properly during the covered period, RGB will repair the product and restore it to normal operation without charge for labor and parts. Consult the factory for information.





## Free Manuals Download Website

<http://myh66.com>

<http://usermanuals.us>

<http://www.somanuals.com>

<http://www.4manuals.cc>

<http://www.manual-lib.com>

<http://www.404manual.com>

<http://www.luxmanual.com>

<http://aubethermostatmanual.com>

Golf course search by state

<http://golfingnear.com>

Email search by domain

<http://emailbydomain.com>

Auto manuals search

<http://auto.somanuals.com>

TV manuals search

<http://tv.somanuals.com>