

OPERATOR'S MANUAL

14 in. BAND SAW

BS14002

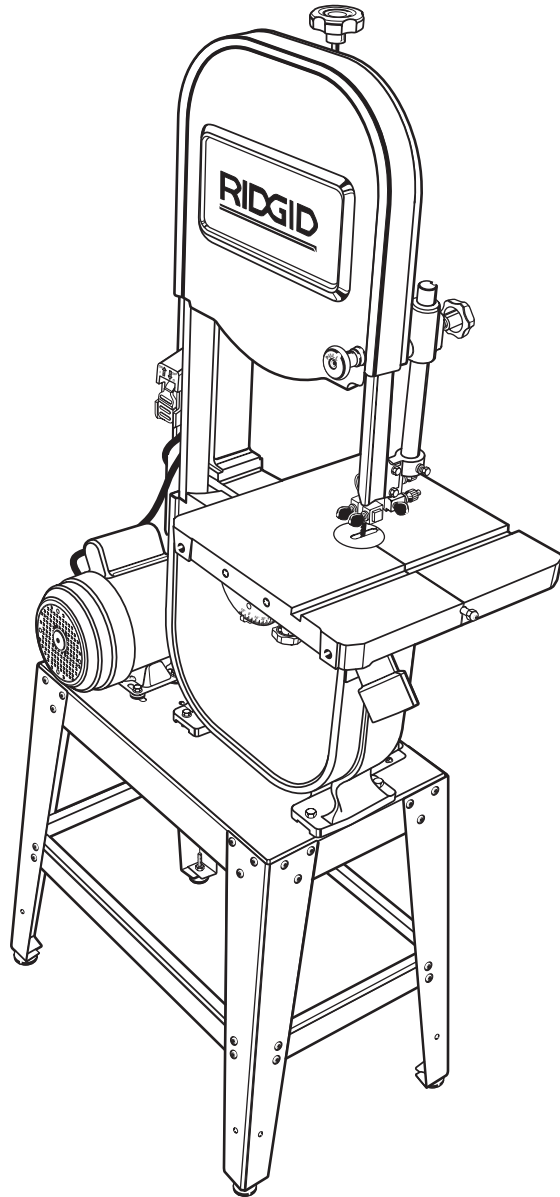

Your new band saw has been engineered and manufactured to our high standards for dependability, ease of operation, and operator safety. When properly cared for, it will give you years of rugged, trouble-free performance.

⚠ WARNING:

To reduce the risk of injury, the user must read and understand the operator's manual before using this product.

Thank you for buying a RIDGID product.

SAVE THIS MANUAL FOR FUTURE REFERENCE

TABLE OF CONTENTS

■ Introduction	2
■ General Safety Rules	3
■ Specific Safety Rules.....	4
■ Symbols.....	5-6
■ Glossary of Terms.....	7
■ Electrical	8-9
■ Features.....	10-11
■ Tools Needed.....	12
■ Loose Parts.....	13-14
■ Assembly	15-24
■ Operation.....	25-27
■ Adjustments.....	28-29
■ Maintenance	30-31
■ Accessories	32
■ Troubleshooting	32-33
■ Warranty	35
■ Parts Ordering/Service	36

INTRODUCTION

This tool has many features for making its use more pleasant and enjoyable. Safety, performance, and dependability have been given top priority in the design of this product making it easy to maintain and operate.

GENERAL SAFETY RULES

WARNING:

Read and understand all instructions. Failure to follow all instructions listed below, may result in electric shock, fire and/or serious personal injury.

READ ALL INSTRUCTIONS

- **KNOW YOUR POWER TOOL.** Safe operation of this power tool requires that you read and understand this operator's manual and all labels affixed to the tool. Learn its applications and limitations as well as the potential hazards.
- **GUARD AGAINST ELECTRICAL SHOCK** by preventing body contact with grounded surfaces such as pipes, radiators, ranges, refrigerator enclosures.
- **KEEP GUARDS IN PLACE** and in good working order. Never operate the tool with any guard or cover removed. Make sure all guards are operating properly before each use.
- **REMOVE ADJUSTING KEYS AND WRENCHES.** Get in the habit - before turning on tool - that hex keys and adjusting wrenches are removed from tool.
- **KEEP THE WORK AREA CLEAN.** Cluttered work areas and work benches invite accidents.
- **DO NOT USE IN DANGEROUS ENVIRONMENTS.** Do not use power tools near gasoline or other flammable liquids, in damp or wet locations, or expose them to rain. Keep the work area well lighted.
- **KEEP CHILDREN AND VISITORS AWAY.** All visitors should wear safety glasses and be kept a safe distance from work area. Do not let visitors contact tool or extension cord while operating.
- **MAKE WORKSHOP CHILDPROOF** with padlocks and master switches or by removing starter keys.
- **DO NOT FORCE THE TOOL** it will do the job better and safer at the rate for which it was designed.
- **USE THE RIGHT TOOL FOR THE JOB.** Do not force the tool or attachment to do a job for which it was not designed for. Use it only the way it was intended.
- **USE THE PROPER EXTENSION CORD.** Make sure your extension cord is in good condition. Use only a cord heavy enough to carry the current your product will draw. An undersized cord will cause a drop in line voltage resulting in loss of power and overheating. A wire gage size (A.W.G.) of at least **16** is recommended for an extension cord 25 feet or less in length. If in doubt, use the next heavier gage. The smaller the gage number, the heavier the cord.
- **WEAR PROPER APPAREL.** Do not wear loose clothing, gloves, neckties, rings, bracelets, or other jewelry that could get caught and draw you into moving parts. Non-slip footwear is recommended. Wear protective covering over long hair.
- **ALWAYS WEAR SAFETY GLASSES WITH SIDE SHIELDS.** Everyday eyeglasses have only impact resistant lenses; they are **NOT** safety glasses.
- **PROTECT YOUR LUNGS.** Wear a face or dust mask if the operation is dusty.
- **PROTECT YOUR HEARING.** Wear hearing protection during extended periods of operation.
- **SECURE WORK.** Use clamps or a vise to hold the work when practical. It's safer than using your hand and frees both hands to operate the tool.
- **DO NOT OVERREACH.** Keep proper footing and balance at all times.
- **MAINTAIN TOOLS WITH CARE.** Keep tools sharp and clean for better and safer performance. Follow instructions for lubricating and changing accessories.
- **DISCONNECT ALL TOOLS.** When not in use, before servicing, or when changing attachments, all tools should be disconnected.
- **AVOID ACCIDENTAL STARTING.** Be sure switch is off when plugging in any tool.
- **USE RECOMMENDED ACCESSORIES.** Consult this operator's manual for recommended accessories. The use of improper accessories may cause risk of injury.
- **NEVER STAND ON TOOL.** Serious injury could occur if the tool is tipped or if the bit is unintentionally contacted.
- **CHECK DAMAGED PARTS.** Before using the tool, a guard or other part that is damaged should be carefully checked to determine that it will operate properly and perform its intended function. Check for alignment of moving parts, binding of moving parts, breakage of parts, mounting and any other conditions that may affect operation. A guard or other part that is damaged must be properly repaired or replaced by an authorized service center to avoid risk of personal injury.
- **NEVER LEAVE TOOL RUNNING UNATTENDED, TURN THE POWER OFF.** Do not leave tool until it comes to a complete stop.
- **DO NOT ABUSE CORD.** Never carry the tool by cord or yank to disconnect from receptacle. Keep cord from heat, oil, and sharp edges.
- **KEEP TOOL DRY, CLEAN, AND FREE FROM OIL AND GREASE.** Always use a clean cloth when cleaning. Never use brake fluids, gasoline, petroleum-based products, or any solvents to clean tool.
- **STAY ALERT AND EXERCISE CONTROL.** Watch what you are doing and use common sense. Do not operate tool when you are tired. Do not rush.
- **INSPECT TOOL CORDS AND EXTENSION CORDS PERIODICALLY** and, if damaged, have repaired by a qualified service technician. Stay constantly aware of cord location and keep it well away from the rotating wheel.
- **NEVER USE IN AN EXPLOSIVE ATMOSPHERE.** Normal sparking of the motor could ignite fumes.
- **USE ONLY OUTDOOR EXTENSION CORDS** with approved ground connection that are intended for use outdoors and so marked.
- **DO NOT USE TOOL IF SWITCH DOES NOT TURN IT ON AND OFF.** Have defective switches replaced by an authorized service center.
- **ALWAYS TURN SWITCH OFF** before disconnecting it to avoid accidental starting.

SPECIFIC SAFETY RULES

- **AVOID AWKWARD OPERATIONS AND HAND POSITIONS** where a sudden slip could cause your hand to move into the blade. ALWAYS make sure you have good balance.
- **ALLOW THE MOTOR TO COME UP TO FULL SPEED** before starting a cut to avoid binding or stalling.
- **REPLACEMENT PARTS.** All repairs, whether electrical or mechanical, should be made by a qualified service technician at an authorized service center.
- **WHEN SERVICING** use only identical Ridgid replacement parts. Use of any other parts may create a hazard or cause product damage.
- **DIRECTION OF FEED.** Feed work into a blade or cutter against the direction or rotation of the blade or cutter only.
- **BLADE COASTS AFTER TURN OFF.**
- **BE SURE THE BLADE PATH IS FREE OF NAILS.** Inspect for and remove nails from lumber before cutting.
- **KEEP HANDS AWAY FROM CUTTING AREA.** Do not hand hold pieces so small that your fingers go under the blade guard. Do not reach underneath work or in blade cutting path with your hands and fingers for any reason.
- **NEVER CUT MORE THAN ONE PIECE AT A TIME** or stack more than one workpiece on the saw table at a time.
- **FIRMLY CLAMP OR BOLT** your saw to a stable, level workbench or table. The most comfortable table height is approximately waist height.
- **DO NOT FEED THE MATERIAL TOO QUICKLY.** Do not force the workpiece against the blade.
- **USE ONLY CORRECT BLADES.** Use the right blade size, style and cutting speed for the material and the type of cut. Blade teeth should point down toward the table.
- **BEFORE MAKING A CUT, BE SURE ALL ADJUSTMENTS ARE SECURE.**
- **ALWAYS SUPPORT LARGE WORKPIECES** while cutting to minimize risk of blade pinching and kickback. Saw may slip, walk or slide while cutting large or heavy boards.
- **DO NOT REMOVE JAMMED CUTOFF PIECES** until blade has stopped.
- **NEVER START THE TOOL** when the blade is in contact with the workpiece.
- **NEVER TOUCH BLADE** or other moving parts during use.
- **BEFORE CHANGING THE SETUP, REMOVING COVERS, GUARDS OR BLADES,** unplug the saw and remove the switch key.
- **HOLD THE WORKPIECE** firmly against the saw table.
- **TO AVOID ACCIDENTAL BLADE CONTACT,** minimize blade breakage, and provide maximum blade support, always adjust the blade guide assembly to just clear the workpiece.
- **KEEP BLADES CLEAN, SHARP, AND WITH SUFFICIENT SET.** Sharp blades minimize stalling and kickbacks.
- **ALWAYS TURN OFF SAW** before disconnecting it to avoid accidental starting when reconnecting to a power source.
- **DO NOT OPERATE THIS TOOL WHILE UNDER THE INFLUENCE OF DRUGS, ALCOHOL OR ANY MEDICATION.**
- **STAY ALERT AND EXERCISE CONTROL.** Watch what you are doing and use common sense. Do not operate tool when you are tired. Do not rush.
- **MAKE SURE WORK AREA HAS AMPLE LIGHTING** to see the work and that no obstructions will interfere with safe operation BEFORE performing any work using your saw.
- **THE BLADE GUIDES HAVE BEEN PRESET AT THE FACTORY.** These settings are functional for some applications. We recommend that you check and adjust blade guide settings before first use of your saw. Refer to “Adjusting thrust bearings, blade guide support, and blade guides” procedures explained in the adjustments section of this operator’s manual.
- **SAVE THESE INSTRUCTIONS.** Refer to them frequently and use them to instruct other users. If you loan someone this tool, loan them these instructions also.



WARNING:











Some dust created by power sanding, sawing, grinding, drilling, and other construction activities contains chemicals known to cause cancer, birth defects or other reproductive harm. Some examples of these chemicals are:

- lead from lead-based paints,
- crystalline silica from bricks and cement and other masonry products, and
- arsenic and chromium from chemically-treated lumber.

Your risk from these exposures varies, depending on how often you do this type of work. To reduce your exposure to these chemicals: work in a well ventilated area, and work with approved safety equipment, such as those dust masks that are specially designed to filter out microscopic particles.



SYMBOLS

Some of the following symbols may be used on this tool. Please study them and learn their meaning. Proper interpretation of these symbols will allow you to operate the tool better and safer.

SYMBOL	NAME	DESIGNATION/EXPLANATION
V	Volts	Voltage
A	Amperes	Current
Hz	Hertz	Frequency (cycles per second)
W	Watt	Power
min	Minutes	Time
~	Alternating Current	Type of current
==	Direct Current	Type or a characteristic of current
n_0	No Load Speed	Rotational speed, at no load
	Class II Construction	Double-insulated construction
.../min	Per Minute	Revolutions, strokes, surface speed, orbits etc., per minute
	Wet Conditions Alert	Do not expose to rain or use in damp locations.
	Read The Operator's Manual	To reduce the risk of injury, user must read and understand operator's manual before using this product.
	Eye Protection	Always wear safety goggles or safety glasses with side shields and a full face shield when operating this product.
	Safety Alert	Precautions that involve your safety.
	No Hands Symbol	Failure to keep your hands away from the blade will result in serious personal injury.
	No Hands Symbol	Failure to keep your hands away from the blade will result in serious personal injury.
	No Hands Symbol	Failure to keep your hands away from the blade will result in serious personal injury.
	No Hands Symbol	Failure to keep your hands away from the blade will result in serious personal injury.
	Hot Surface	To reduce the risk of injury or damage, avoid contact with any hot surface.

SYMBOLS

The following signal words and meanings are intended to explain the levels of risk associated with this product.

SYMBOL	SIGNAL	MEANING
	DANGER:	Indicates an imminently hazardous situation, which, if not avoided, will result in death or serious injury.
	WARNING:	Indicates a potentially hazardous situation, which, if not avoided, could result in death or serious injury.
	CAUTION:	Indicates a potentially hazardous situation, which, if not avoided, may result in minor or moderate injury.
	CAUTION:	(Without Safety Alert Symbol) Indicates a situation that may result in property damage.

SERVICE

Servicing requires extreme care and knowledge and should be performed only by a qualified service technician. For service we suggest you return the product to your nearest **AUTHORIZED SERVICE CENTER** for repair. When servicing, use only identical replacement parts.



WARNING:

To avoid serious personal injury, do not attempt to use this product until you read thoroughly and understand completely the operator's manual. Save this operator's manual and review frequently for continuing safe operation and instructing others who may use this product.



WARNING:



The operation of any power tool can result in foreign objects being thrown into your eyes, which can result in severe eye damage. Before beginning power tool operation, always wear safety goggles or safety glasses with side shields and a full face shield when needed. We recommend Wide Vision Safety Mask for use over eyeglasses or standard safety glasses with side shields. Always use eye protection which is marked to comply with ANSI Z87.1.

SAVE THESE INSTRUCTIONS

GLOSSARY OF TERMS

Bevel Cut

A cutting operation made with the saw table at any angle other than 90° to the blade.

Compound Cut

A compound cut is a cut made using a miter angle and a bevel angle at the same time.

Crosscut

A cutting or shaping operation made across the grain or the width of the workpiece.

Freehand (for band saw)

Performing a cut without the workpiece properly supported on the saw table.

Gum

A sticky, sap-based residue from wood products.

Kerf

The material removed by the blade in a through cut or the slot produced by the blade in a non-through cut or partial cut.

Kickback

A hazard that can occur when the blade binds or stalls, throwing the workpiece back toward operator.

Leading End

The end of the workpiece pushed into the cutting tool first.

Miter Cut

A cutting operation made with the workpiece at any angle to the blade other than 90°.

Push Stick

A device used to feed the workpiece through the saw blade during narrow cutting operations. It helps keep the operator's hands well away from the blade.

Resaw

A cutting operation to reduce the thickness of the workpiece to make thinner pieces.

Resin

A sticky, sap-based substance that has hardened.

Ripping

A cutting operation along the length of the workpiece.

Saw Blade Path

The area directly in line — over, under, behind or in front of the blade. As it applies to the workpiece, that area which will be or has been cut by the blade.

Set

The distance that the tip of the saw blade tooth is bent (or set) outward from the face of the blade.

FPM

2,700 surface feet per minute, used in reference to surface speed of blade.

Throw-Back

Saw throwing back a workpiece in a manner similar to a kickback. Usually associated with a cause other than the kerf closing, such as a workpiece being dropped into the blade or being placed inadvertently in contact with the blade.

Through Sawing

Any cutting operation where the blade extends completely through the thickness of the workpiece.

Workpiece

The item on which the cutting operation is being done. The surfaces of a workpiece are commonly referred to as faces, ends, and edges.

Worktable

The surface on which the workpiece rests while performing a cutting or sanding operation.

ELECTRICAL

EXTENSION CORDS

Use only 3-wire extension cords that have 3-prong grounding plugs and 3-pole receptacles that accept the tool's plug. When using a power tool at a considerable distance from the power source, use an extension cord heavy enough to carry the current that the tool will draw. An undersized extension cord will cause a drop in line voltage, resulting in a loss of power and causing the motor to overheat. Use the chart provided below to determine the minimum wire size required in an extension cord. Only round jacketed cords listed by Underwriter's Laboratories (UL) should be used.

**Ampere rating (on tool faceplate)

Cord Length	Wire Size (A.W.G.)					
	0-2.0	2.1-3.4	3.5-5.0	5.1-7.0	7.1-12.0	12.1-16.0
25'	16	16	16	16	14	14
50'	16	16	16	14	14	12
100'	16	16	14	12	10	—

**Used on 12 gauge - 20 amp circuit.

NOTE: AWG = American Wire Gauge

When working with the tool outdoors, use an extension cord that is designed for outside use. This is indicated by the letters "WA" on the cord's jacket.

Before using an extension cord, inspect it for loose or exposed wires and cut or worn insulation.

WARNING:

Keep the extension cord clear of the working area. Position the cord so that it will not get caught on lumber, tools or other obstructions while you are working with a power tool. Failure to do so can result in serious personal injury.

WARNING:

Check extension cords before each use. If damaged replace immediately. Never use tool with a damaged cord since touching the damaged area could cause electrical shock resulting in serious injury.

ELECTRICAL CONNECTION

This tool is powered by a precision built electric motor. It should be connected to a **power supply that is 120 volts, 60 Hz, AC only (normal household current)**. Do not operate this tool on direct current (DC). A substantial voltage drop will cause a loss of power and the motor will overheat. If the saw does not operate when plugged into an outlet, double check the power supply.

SPEED AND WIRING

The no-load speed of this tool is approximately 3000 fpm. This speed is not constant and decreases under a load or with lower voltage. For voltage, the wiring in a shop is as important as the motor's horsepower rating. A line intended only for lights cannot properly carry a power tool motor. Wire that is heavy enough for a short distance will be too light for a greater distance. A line that can support one power tool may not be able to support two or three tools.

GROUNDING INSTRUCTIONS

In the event of a malfunction or breakdown, grounding provides a path of least resistance for electric current to reduce the risk of electric shock. This tool is equipped with an electric cord having an equipment-grounding conductor and a grounding plug. The plug must be plugged into a matching outlet that is properly installed and grounded in accordance with all local codes and ordinances.

Do not modify the plug provided. If it will not fit the outlet, have the proper outlet installed by a qualified electrician. Improper connection of the equipment-grounding conductor can result in a risk of electric shock. The conductor with insulation having an outer surface that is green with or without yellow stripes is the equipment-grounding conductor. If repair or replacement of the electric cord or plug is necessary, do not connect the equipment-grounding conductor to a live terminal.

Check with a qualified electrician or service personnel if the grounding instructions are not completely understood, or if in doubt as to whether the tool is properly grounded.

Repair or replace a damaged or worn cord immediately. This tool is intended for use on a circuit that has an outlet like the one shown in figure 1. It also has a grounding pin like the one shown.

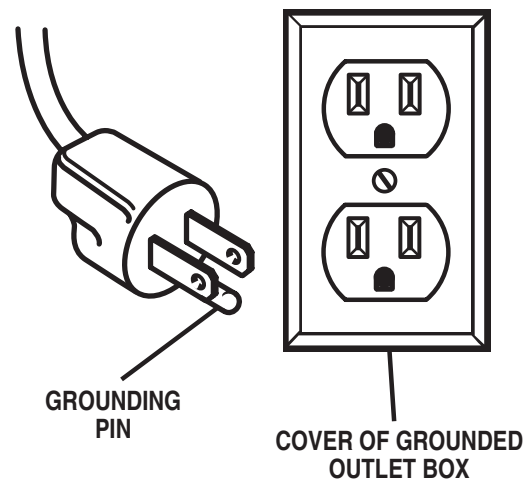

Fig. 1

ELECTRICAL

CHANGING MOTOR VOLTAGE

See Figures 2 - 5.

⚠ WARNING:

Electric shock can kill. To reduce the risk of serious personal injury, never connect plug to power source until all assembly steps are completed.

NOTE: The band saw is prewired at the factory for 120 volts, 60Hz. Use the following procedures to change motor voltage from 120 volts to 240 volts.

- Unplug the saw.
- Located on the side of the motor is the junction box. Remove the Phillips screw at the back of the junction box then lift off the cover.
- Remove and discard the electrical tape from the wire connectors. Remove wire connectors.
- Reconnect the leads.
- Reinstall the wire connectors and wrap each wire with two layers of new UL listed electrical tape.
- Recheck your wiring with the wiring diagrams.
- Reinstall the junction box cover using the Phillips screw.
- Cut off the 120 volt power cord plug and replace it with a 3-prong 240 volt, 15 amp. UL listed plug.
- Connect the power cord white and black leads, respectively, to the "hot" plug blade terminals. Connect the power cord green grounding wire to the plug ground prong terminal.
- Plug your table saw into a 220-240 volt, 15 amp., 3-prong receptacle. Make certain the receptacle is connected to a 240 volt, AC power supply through a 240 volt branch circuit having at least a 15 amp capacity and protected by a 15 amp time-delay fuse or circuit breaker.

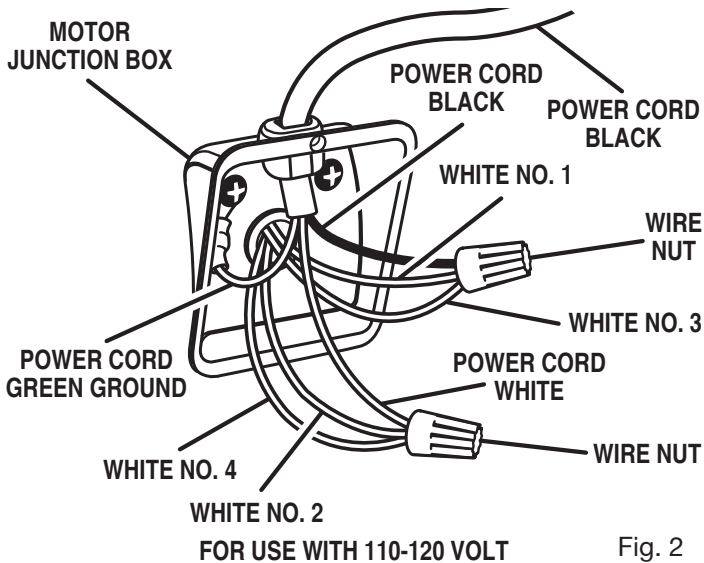
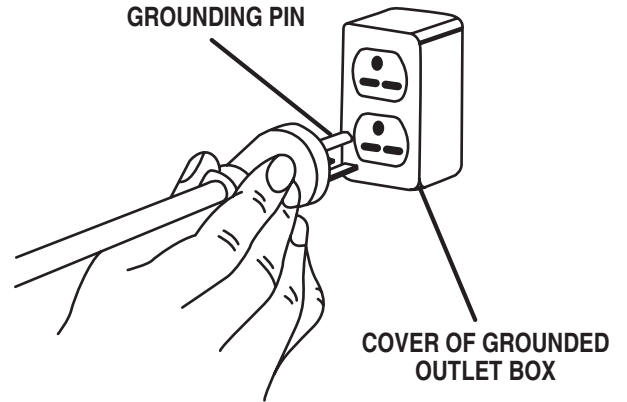
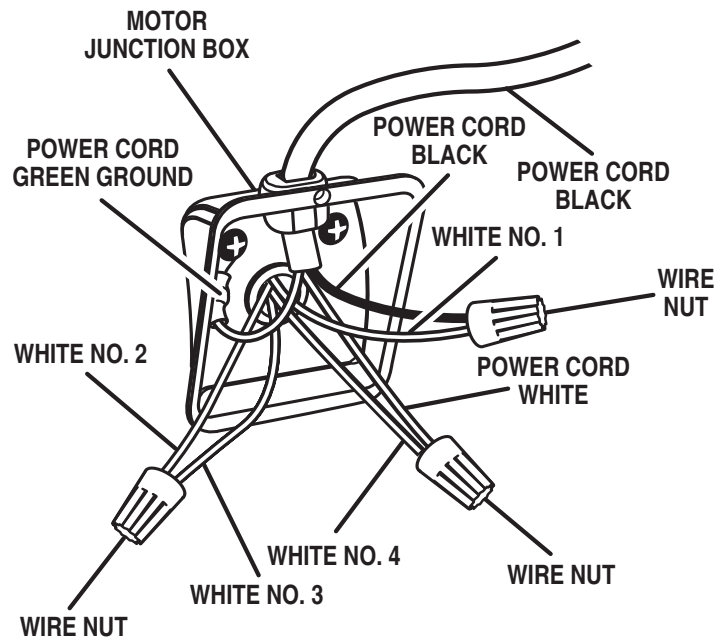

Fig. 2



FOR USE WITH 220-240 VOLT

Fig. 3



FOR USE WITH 220-240 VOLT

Fig. 4

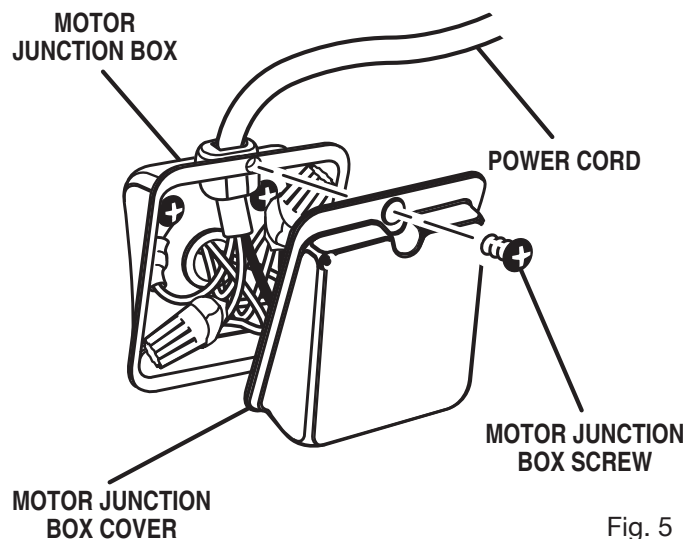

Fig. 5

FEATURES

SPECIFICATIONS

- Blade Width 1/8 in. to 3/4 in. (3 mm to 19 mm)
- Blade Length 93-1/2 in. (237.5 cm)
- Table Size..... 14 in. x 14 in. (355 mm x 355 mm)
- Input..... 120 Volt, 60Hz, 10 amps
- No Load Speed.....2700 FPM
- Dust Port.....2-1/4 in. (57.15 mm)
- Net Weight 187 lbs. (85 kg)

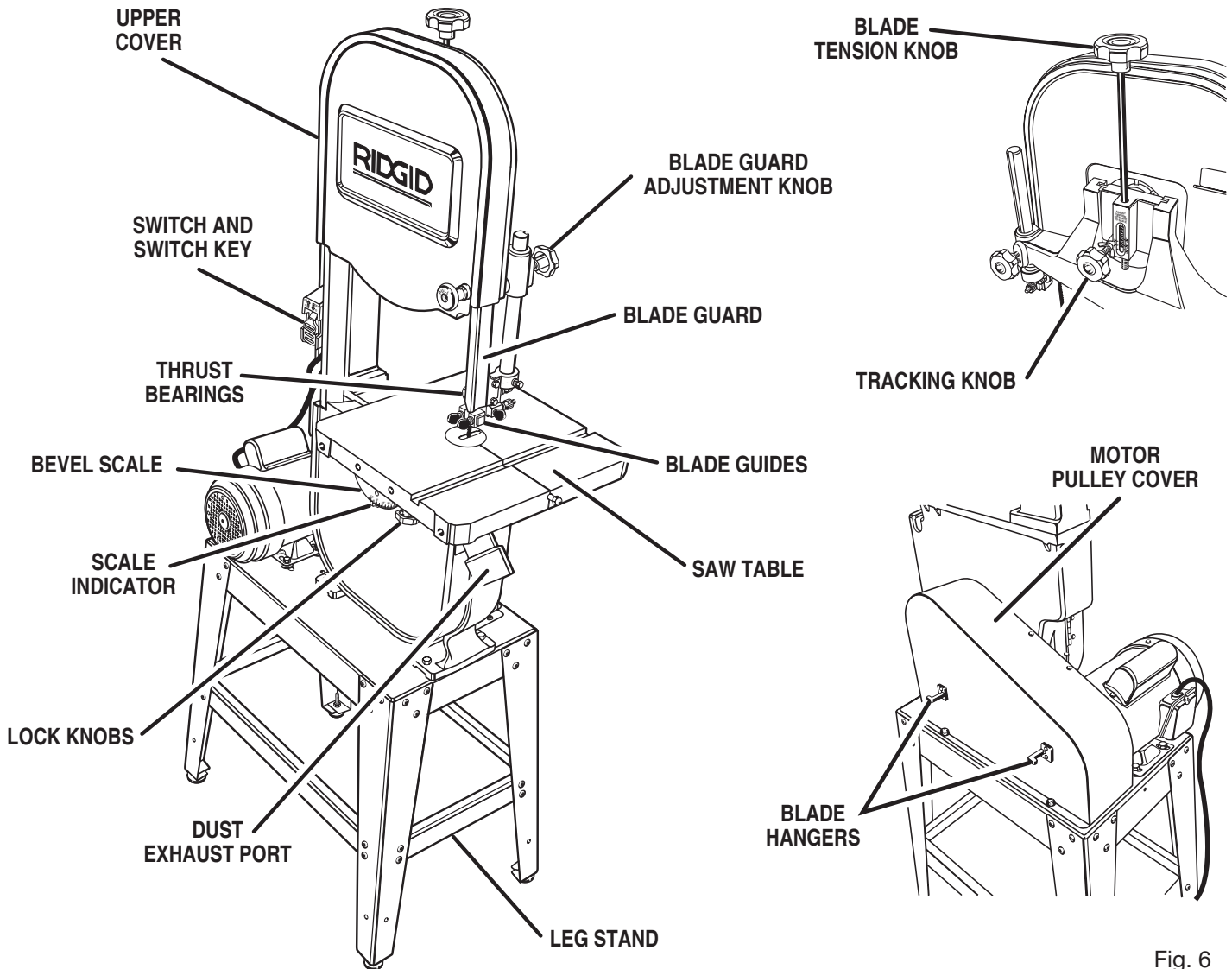

Fig. 6

FEATURES

KNOW YOUR BAND SAW

See Figure 6.

Before attempting to use this product, familiarize yourself with all operating Features and Safety Rules.

BLADE TENSION KNOB

Rotation of this knob will increase or decrease the tension on the blade.

TRACKING KNOB

Adjusts tracking to keep blade centered on the wheels.

BLADE GUIDES

Blade guides provide full support of the adjustable blade.

THRUST BEARINGS

Thrust bearings support the back of the blade and are adjustable for the various blade widths.

BLADE GUARD ADJUSTMENT KNOBS

Use the blade guide adjustment knobs to adjust the blade guide assembly. This keeps the blade from twisting or breaking.

SAW TABLE WITH 90° STOPS

Saw table tilts for angular cuts. Ensures saw table is perpendicular to blade. Use the bevel scale under saw table to measure angular settings.

TABLE LOCK KNOBS

Loosening the table lock knobs allows the saw table to be tilted at different angles. Tightening the table lock knobs locks the saw table in place.

HOUSING COVERS

Pull knob to expose wheels during blade changes or to clean out sawdust build-up.

DUST EXHAUST PORT

A 2-1/4 in. (57.15 mm) dust exhaust port makes dustless cutting possible by blowing the dust away from the user. Attach to the dust exhaust port when using a dust collection system or wet/dry vac.

BLADE GUARD

Protects the operator from coming in contact with the blade.

BLADE HANGERS

Extra blades may be stored here.

TOOLS NEEDED

The following tools (not included) are needed for checking adjustments of your saw or for installing the blade:



COMBINATION WRENCH (2)
10 mm, 14 mm

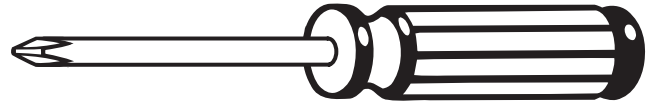

PHILLIPS SCREWDRIVER

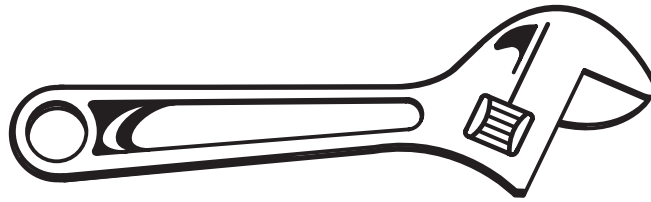

ADJUSTABLE WRENCH

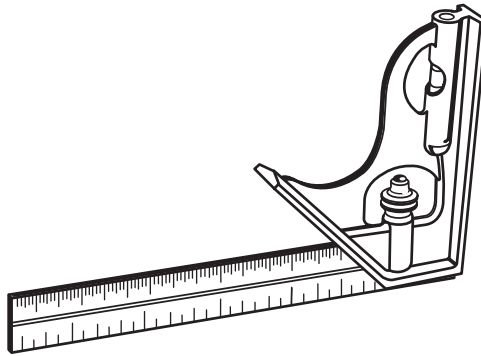

COMBINATION SQUARE



STRAIGHT EDGE

Fig. 7

LOOSE PARTS

The following items are included with your band saw:

Base	1
Legs.....	4
Leveling Feet	4
Hex Nuts (3/8-16)	8
Leg Brace, Long	2
Leg Brace, Short	2
Carriage Bolts, (M8 x 1.25-16)	40
Flat Washers.....	40
Lock Washers.....	40
Hex Nuts (M8).....	40
Screws.....	2
Motor Support.....	1
Plate Support	1
Operator's Manual (Not Shown)	

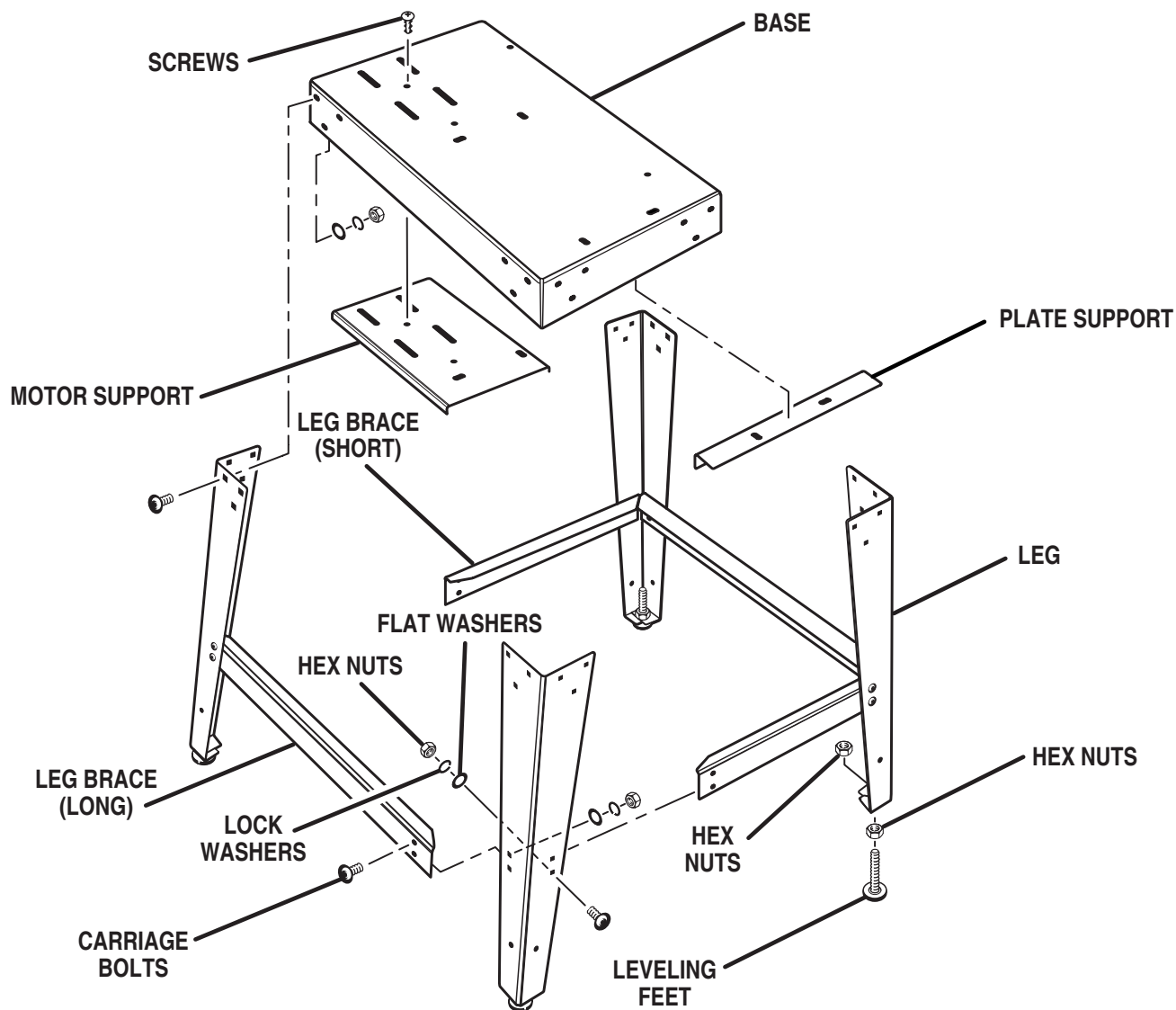

Fig. 8

LOOSE PARTS

The following items are included with your band saw:

V-Belt.....	1
Saw Table.....	1
Pulley Cover.....	1
Motor with Switch.....	1
Band Saw.....	1
Trunnion Support.....	1
Dust Chute.....	1
Bevel Scale.....	1
Scale Indicator.....	1
Rubber Grommet.....	4
Switch Key.....	1
Blade Hanger.....	2
Lock Knob.....	2

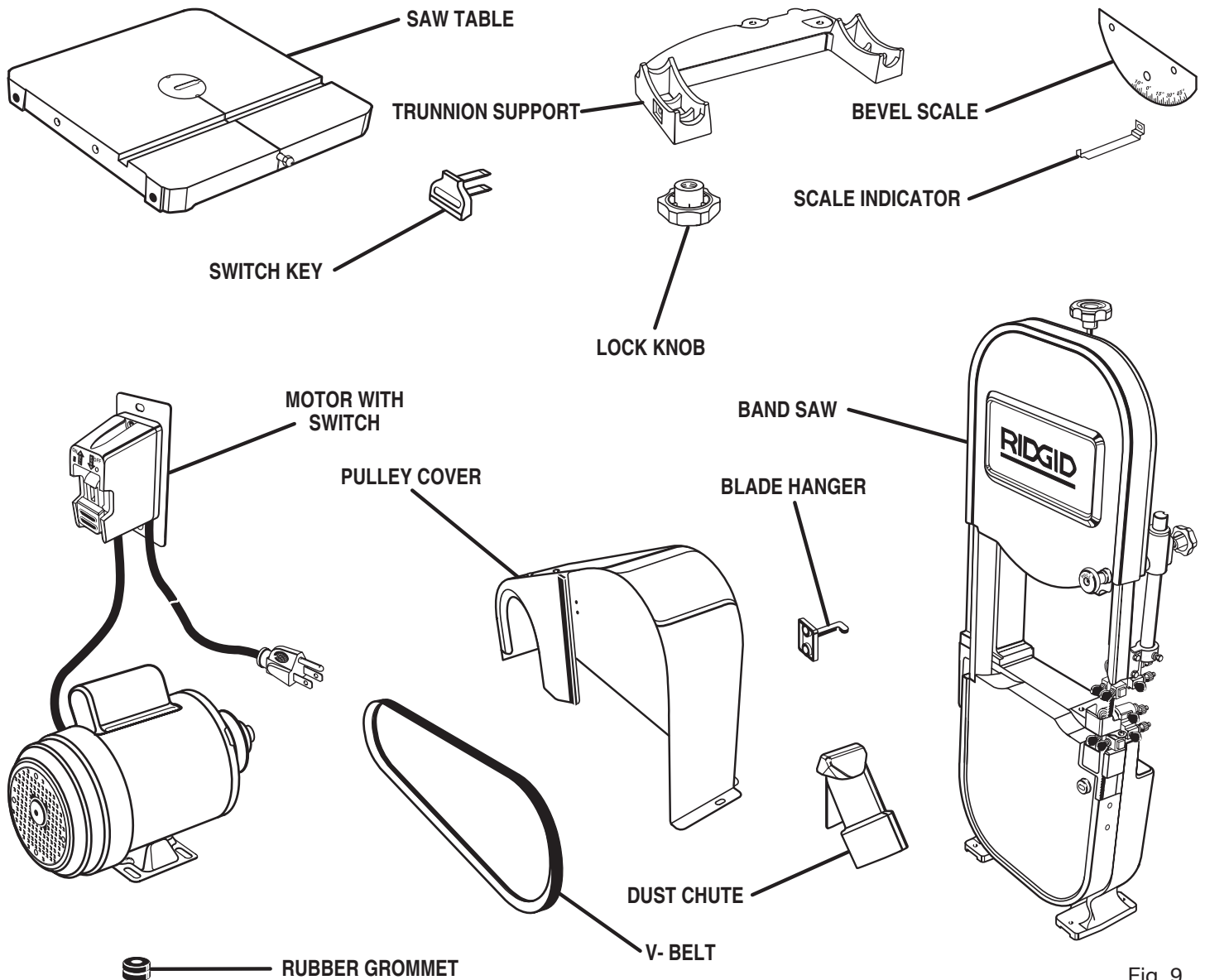

Fig. 9

ASSEMBLY

UNPACKING

This product requires assembly.

- Carefully remove the tool and any accessories from the box. Place it on a level work surface.

NOTE: This tool is heavy. To avoid back injury, lift with your legs, not your back, and get help when needed.

- Inspect the tool carefully to make sure no breakage or damage occurred during shipping.
- Do not discard the packing material until you have carefully inspected the tool, identified all loose parts, and satisfactorily operated the tool.
- Remove the protective oil that is applied to all unpainted metal surfaces. Use any ordinary household type grease and spot remover.
- Apply coat of paste wax to the saw table.
- The saw is factory set for accurate cutting. After assembling it, check for accuracy. If shipping has influenced the settings, refer to specific procedures explained in the operation and maintenance sections of this manual.
- If any parts are damaged or missing, please call 1-866-539-1710 for assistance.

WARNING:

If any parts are missing, do not operate this tool until the missing parts are replaced. Failure to do so could result in possible serious personal injury.

WARNING:

Do not attempt to modify this tool or create accessories not recommended for use with this tool. Any such alteration or modification is misuse and could result in a hazardous condition leading to possible serious personal injury.

WARNING:

Do not connect to power supply until assembly is complete. Failure to comply could result in accidental starting and possible serious personal injury.

ATTACHING LEVELING FEET

See Figure 10.

- Locate the following items:
 - 4 leveling feet
 - 8 hex nuts, (3/8-16)
- From the loose parts find the following items:
 - 4 legs
- Thread a hex nut on each of the leveling feet and screw it down towards the rubber foot.

- Put the leveling feet through the holes in the bottom of each leg.
- Thread another hex nut on each of the leveling feet and hand tighten until they are next to the bottom support of the leg.

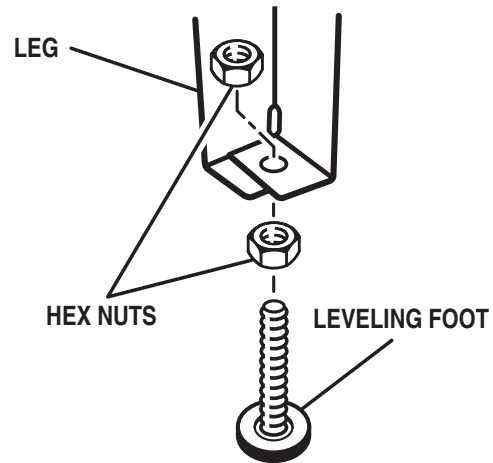

Fig. 10

WARNING:

To reduce the risk of injury from unexpected saw or work movement, leveling feet must be adjusted so that saw does not rock. After the band saw has been attached to the leg stand, it will be necessary to adjust the leveling feet.

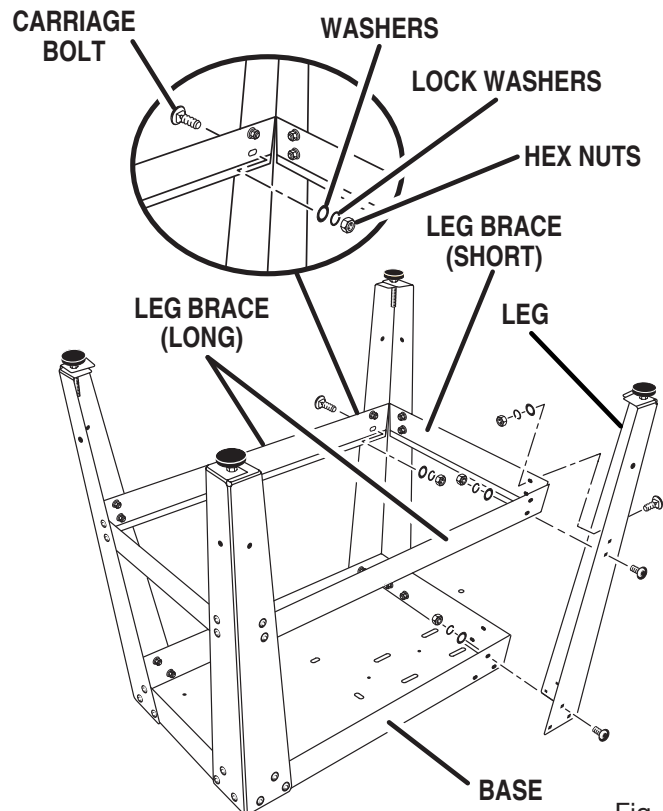

Fig. 11

ASSEMBLY

ASSEMBLING LEG STAND

See Figures 11 - 12.

- Locate the following hardware:
 - 40 carriage bolts (M8 x 1.25-16)
 - 40 washers (M8)
 - 40 lock washers (M8)
 - 40 nuts (M8)
 - 4 legs (with attached leveling feet)
 - 2 leg braces (short)
 - 2 leg braces (long)
 - 1 base
 - 2 screws
 - 1 motor support
- Place base upside down on a level surface. Fasten four legs to top using carriage bolts, washers, lock washers, and nuts, as shown (with nuts and washers to the inside).
NOTE: Legs fasten to outside of top. Do not tighten at this time.
- Fasten two long leg braces and two short leg braces to legs using carriage bolts, washers, lock washers, and nuts, as shown. Finger tighten only.
- Turn assembly over onto the legs. Be sure all four feet sit flat on the ground. Adjustment of the feet will be completed after the band saw is attached to the stand.
- Place motor support under the base.
- Insert screws through holes in the base and thread into motor support as shown.
- Tighten all stand fasteners at this time.
- With the aid of a second person, lift the band saw out of the shipping container and place onto the base. Be sure front of saw faces leg stand front by aligning holes.

CAUTION:

Do not lift the saw without help. Hold it close to your body. Keep your knees bent and lift with your legs, not your back. Ignoring these precautions can result in back injury.

MOUNTING BAND SAW TO LEG STAND

See Figure 13.

- Locate the following hardware:
 - 4 hex head bolts, (M8 x 35)
 - 8 washers, (M8)
 - 4 lock washers, (M8)
 - 4 hex nuts, (M8)
 - 1 plate support
- Place the saw body on the leg stand. Line up holes in saw body with holes in stand, as shown.
- Place support plate to the underside of stand, as shown.
- Insert a bolt through a washer, then through a hole in the saw base and a hole in the leg stand. Add a washer, lock washer and hex nut. Hand tighten.
- Repeat for remaining holes. Tighten all hardware with a wrench. You may find it helpful to use one wrench to hold the head of the bolt and one to tighten the hex nut.

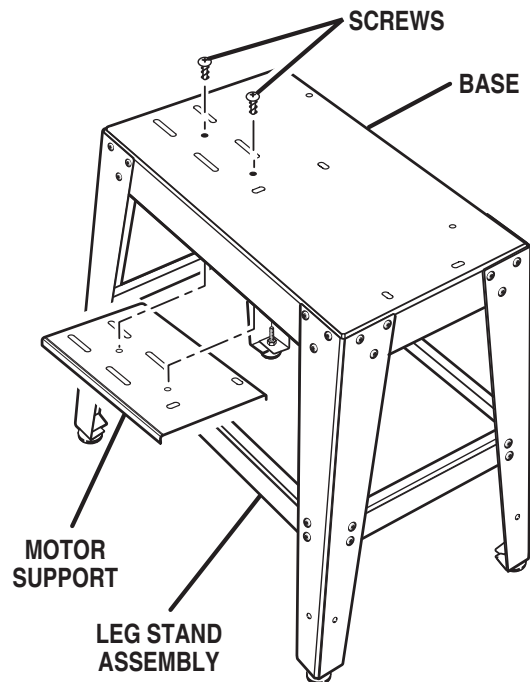

Fig. 12

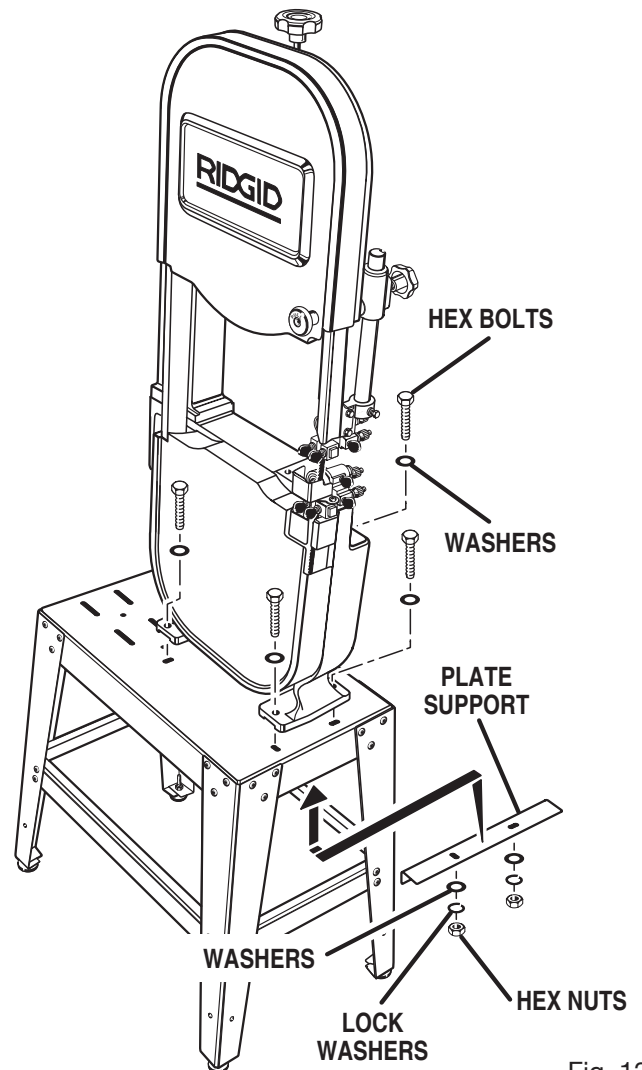

Fig. 13

ASSEMBLY

MOUNTING THE MOTOR ASSEMBLY

See Figure 14.

- Locate the following items:
 - 4 hex bolts, (M8 x 35)
 - 8 washers, (M8)
 - 4 lock washers, (M8)
 - 4 hex nuts, (M8)
 - 4 rubber grommets
 - 1 motor with switch assembly
- To mount motor, place four rubber grommets over holes in leg stand.
- NOTE:** Use of rubber grommets is essential for eliminating excessive vibration.
- Set motor on rubber grommets and fasten to leg stand using hex head bolts, washers, lock washers, and hex nuts, as shown. Do not tighten at this time.

INSTALLING THE V-BELT

See Figures 15 - 17.

- Locate the following item:
 - 1 V-belt
- Align the inside edge of the motor pulley with the inside edge of the large pulley using a straight edge. With a 3mm hex wrench, adjust one or both pulleys by loosening the set screw and moving the pulley(s) until they line up with each other. Tighten set screws.
- Place V-belt over both pulleys.
- Tension V-belt by moving motor away from the saw body and tighten the motor mount nuts. Do not overtighten motor mount bolts. Tighten just enough to tension belt. Belt is properly tensioned when finger pressure between the two pulleys causes approximately 1/2 in. deflection.

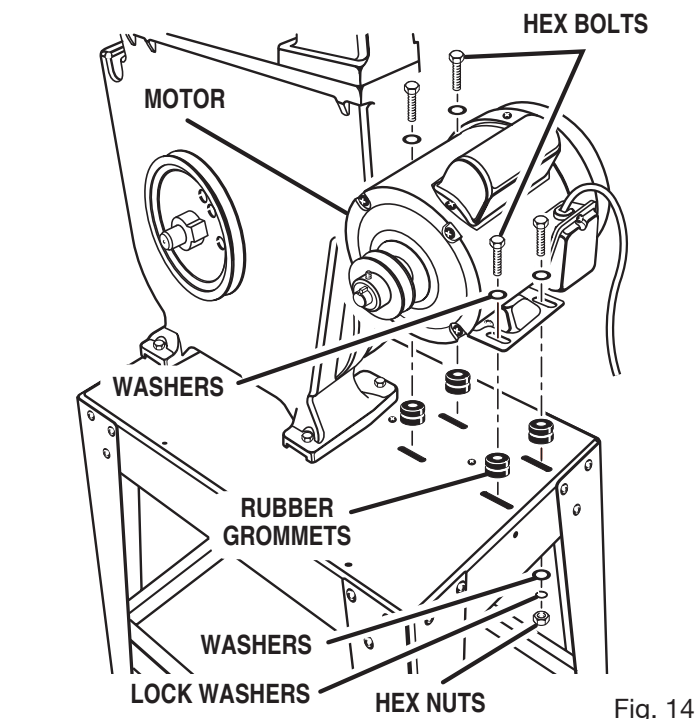

Fig. 14

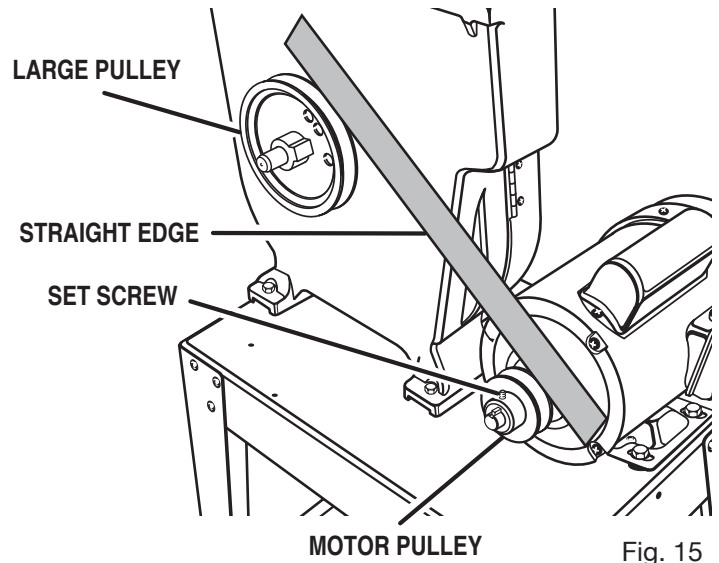

Fig. 15

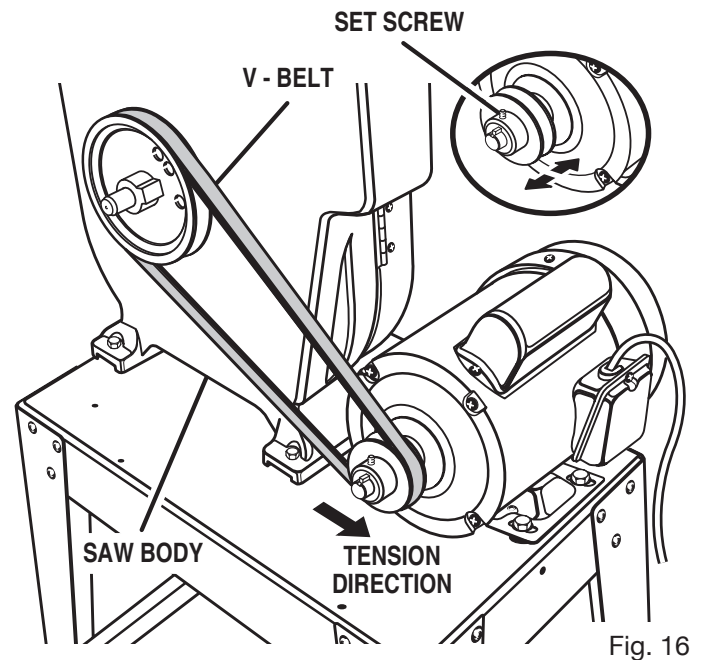

Fig. 16

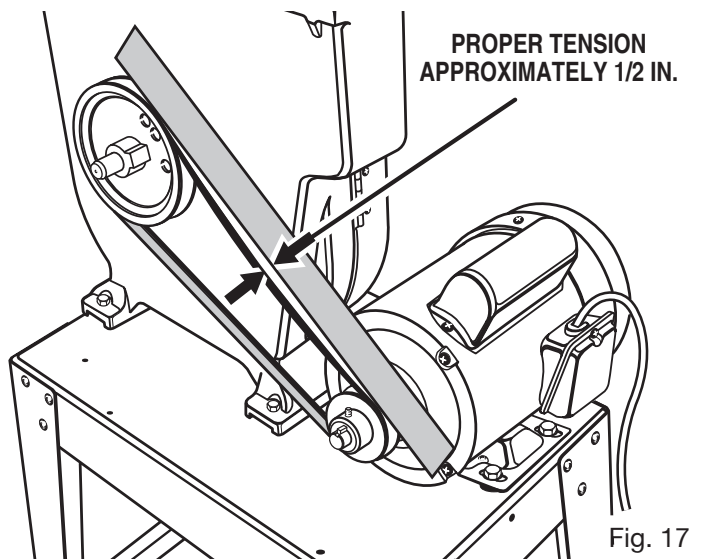

Fig. 17

ASSEMBLY

MOUNTING BLADE HANGERS

See Figure 18.

- Locate the following items.
 - 4 pan head screws, (M4 x 0.7-10)
 - 4 hex nuts, (M4 x 0.7)
 - 4 lock washers, (M4)
 - 2 blade hangers
 - 1 pulley cover
- Align blade hangers over the holes on opposite sides of the pulley cover. Make sure they are pointing in opposite directions. Fasten blade hangers using pan head screws, lock washers, and hex nuts, as shown.

MOUNTING THE PULLEY COVER

See Figure 19.

- Locate the following items.
 - 3 pan head screws, (M5 x 0.8-12)
 - 6 washers, (M5)
 - 3 hex nuts, (M5)
- Place pulley cover over both pulleys. Align holes in the pulley cover to holes in the leg stand. Fasten pulley cover to leg stand using pan head screws, washers, and hex nuts, as shown.

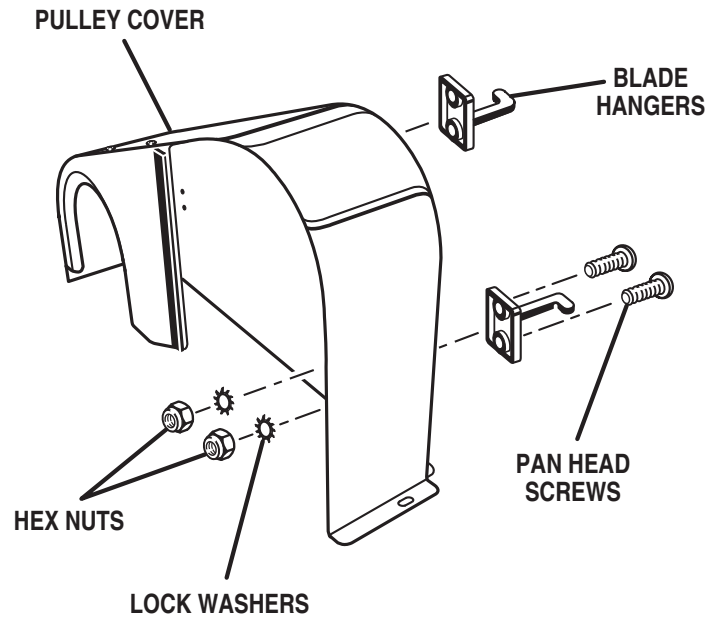

Fig. 18

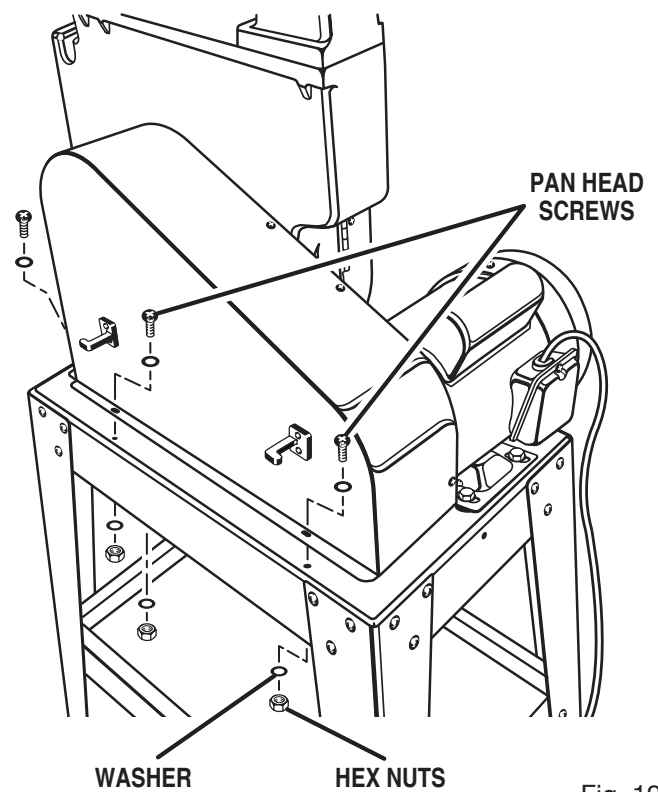

Fig. 19

ASSEMBLY

MOUNTING THE SWITCH BOX

See Figure 20.

- Locate the following hardware:
 - 2 pan head screws (M5 x 0.8-12)
 - 2 lock washers (M5)
- Mount switch assembly to frame as shown using pan head screws. Thread screws into band saw chassis using a Phillips screwdriver.

MOUNTING THE DUST CHUTE

See Figure 21.

- Locate the following items:
 - 2 pan head screws (M6 x 1)
 - 1 dust chute
- Open lower blade guard cover and install dust chute pointing down. Thread pan head screws from the inside of the lower blade guard cover into the dust chute.
- Close lower blade guard cover.

MOUNTING THE TABLE TRUNNION SUPPORT TO BAND SAW

See Figure 22.

- Locate the following items:
 - 2 hex head bolts (M8 x 35)
 - 2 lock washers (M8)
 - 1 table stop bolt (M8 x 80)
 - 1 nut (M8)
 - 1 trunnion support
- Place trunnion support on saw body and align using pins mounted as shown.
- Thread hex head bolts into band saw using lock washers. Tighten.
- Thread hex nut half way onto table stop bolt. Thread table stop bolt into trunnion support.

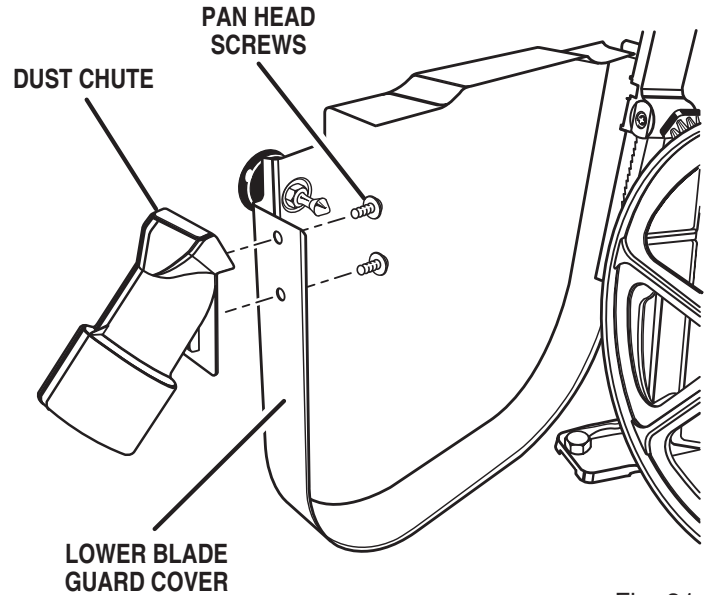
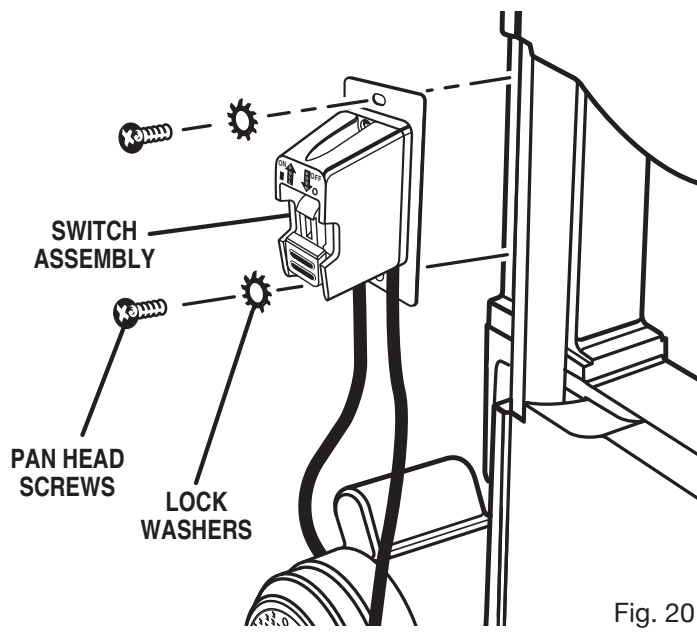

Fig. 21

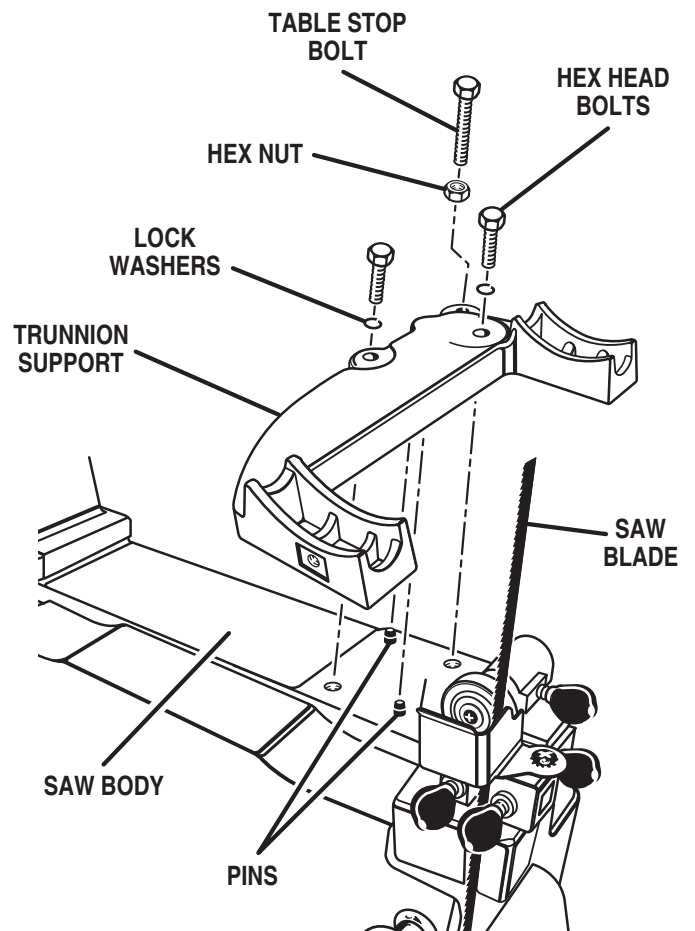

Fig. 22

ASSEMBLY

MOUNTING BEVEL SCALE TO SAW TABLE

See Figure 23.

- Locate the following items:
 - 2 flat head screws, (M5 x 0.8-15)
 - 2 washers, (M5)
 - 2 hex nuts, (M5 x 0.8)
 - 1 bevel scale
 - 1 saw table
- Align bevel scale on the inside edge of the saw table with the text facing out. Insert the screws through the table and bevel scale as shown.

- Install a washer and nut. Tighten

INSTALLING BEVEL SCALE INDICATOR

See Figure 24.

- Locate the following items:
 - 1 scale indicator
 - 1 pan head screw, (M5 x 0.8-6)
- Insert screw through the slot in the scale indicator and into the trunnion support. Tighten.

MOUNTING THE SAW TABLE TO SAW BODY

See Figures 25 - 26.

- Locate the following items:
 - 1 saw table
 - 2 lock knobs
- To mount saw table, remove throat plate and pull table pin out from the table. Rotate saw table 90° and guide saw blade through slot in saw table.
- Rotate saw table back and place table screws into trunnion support. Attach using lock knobs.

⚠ WARNING:

Unit is shipped with blade installed. Do not plug in or operate unit unless the blade is adjusted and aligned per section titled "Installing and Adjusting the Blade". Failure to do so could result in possible serious personal injury.

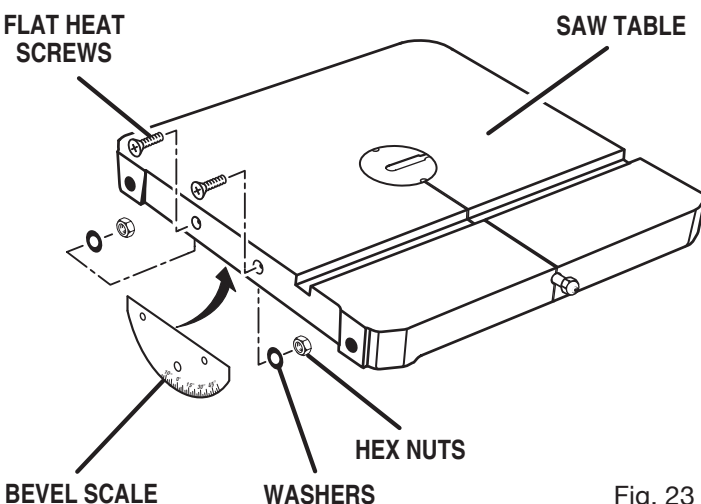

Fig. 23

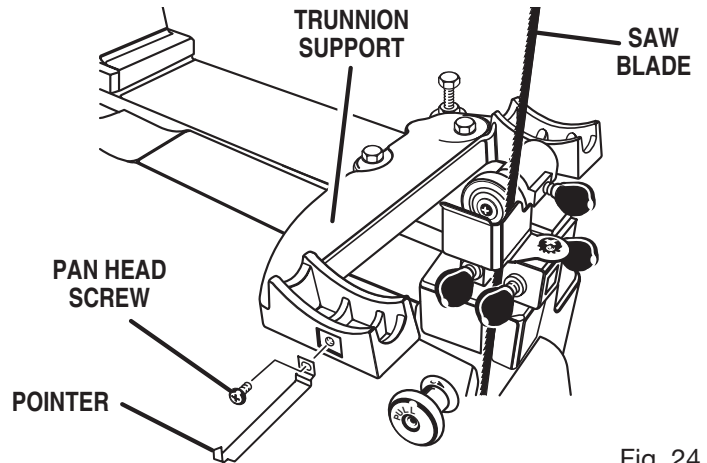

Fig. 24

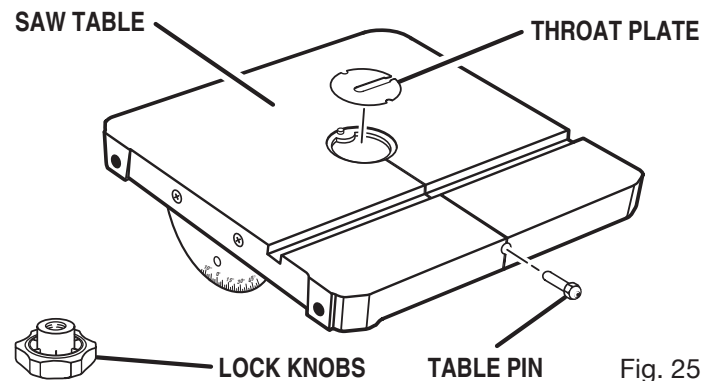

Fig. 25

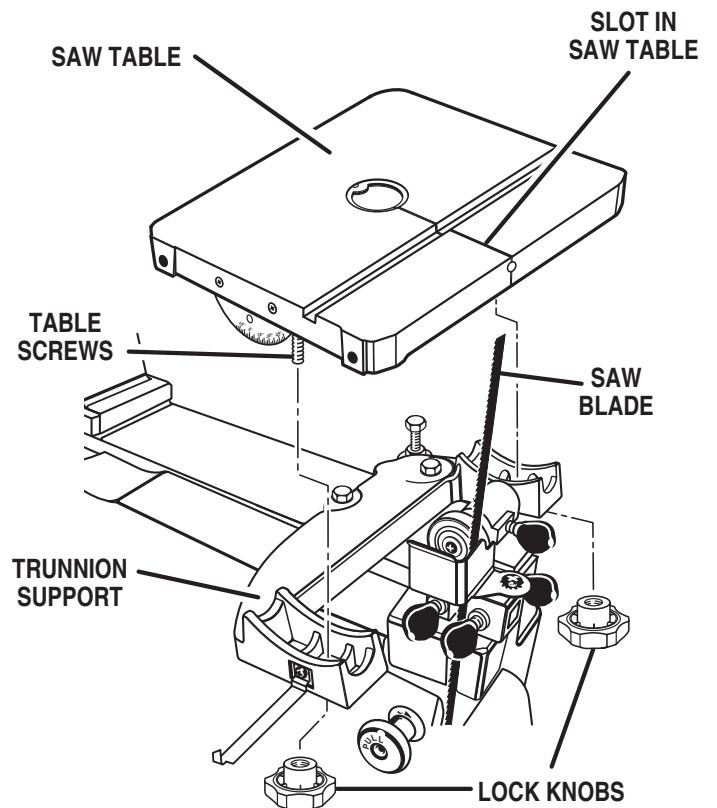

Fig. 26

ASSEMBLY

- Replace throat plate and table pin.
- Transportation and handling may have caused some fasteners to loosen. Before operating, check all screws, bolts and nuts to make sure they are snug. Operate machine only after reading the entire operator's manual including blade tracking, blade guide adjustments, and safety rules.

ADJUSTING BLADE TENSION

See Figures 27 - 28.

As you become familiar with the saw, you may find it necessary to change the blade tension from the initial setting. Changes in blade width and the type of material being cut will have an effect on blade tension.

Keep in mind that too little or too much blade tension can cause blade breakage.

- Unplug the saw and remove switch key.
- Turn blade tension knob clockwise to tension blade. A gauge on the upper wheel slide bracket indicates the approximate tension according to the width of the blade. Initially, set the blade tension gauge to correspond with the blade width.

NOTE: Adjustments of blade tension can be made at anytime.

Another method of checking blade tension has to do with the sound the blade makes when plucked like a guitar string.

- Pluck the back straight edge on the coasting side opposite the blade guides while turning the tension knob. Sound should be a musical note. Sound becomes higher pitched as tension increases.

Using either method to check blade tension can be developed with practice.

- Never increase blade tension so tight as to completely compress the spring. When completely compressed, the spring can no longer act as a shock absorber.

TRACKING THE BLADE

See Figure 29.

Blade must be properly tensioned before adjusting blade tracking. Make sure blade guides and blade bearings do not interfere with the blade.

- Open upper cover. Rotate the wheel forward by hand and observe the position of the blade on the wheel. It should be in the center.
- If adjustment is necessary, loosen wing nut, tighten knob slightly to move blade toward rear of machine. Slightly loosening the knob will cause the blade to track toward the front of the machine.
- Tighten nut after blade is tracking in the center of the wheel.

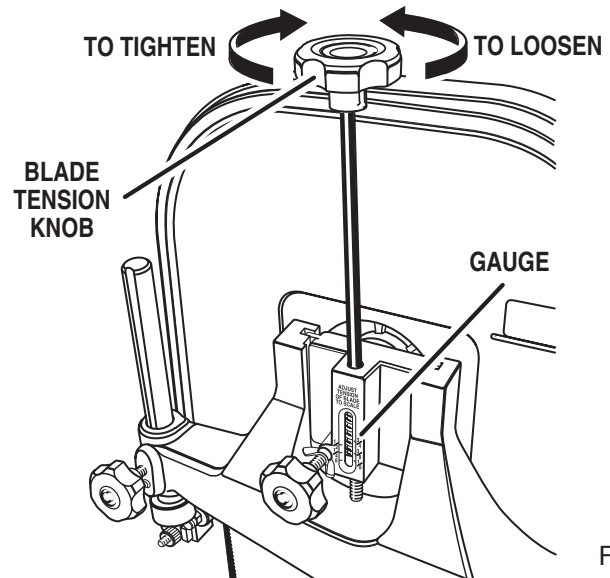

Fig. 27

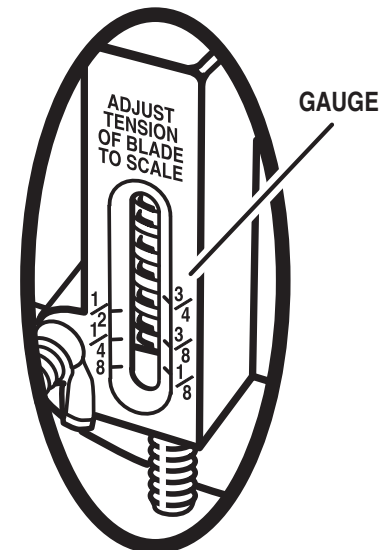

Fig. 28

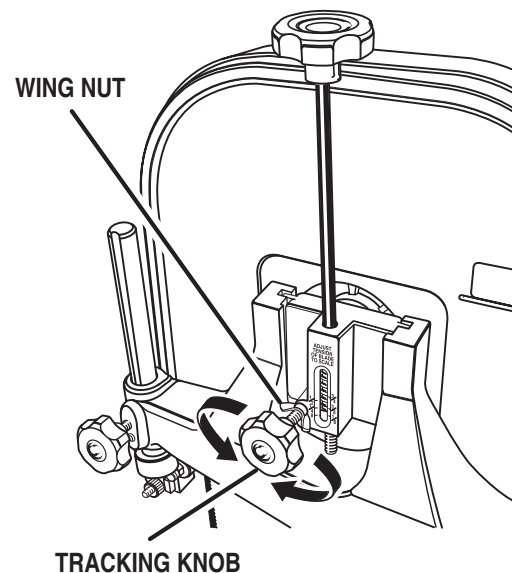

Fig. 29

ASSEMBLY

ADJUSTING TABLE STOP

See Figure 30.

WARNING:

Failure to turn the saw off, remove the switch key, and unplug the saw could result in accidental starting causing possible serious personal injury.

- Unplug the saw and remove switch key.
- Loosen lock knobs and tilt table left until it rests against table stop.
- If an adjustment is necessary, loosen jam nut and turn table stop bolt left or right to raise or lower the stop.
- Tighten jam nut to hold table stop bolt in place.
- Tighten lock knobs by turning clockwise.

SQUARING THE SAW TABLE TO THE BLADE

See Figure 31.

- Turn the blade guide adjustment knob counterclockwise to unlock the blade guide assembly. Raise the blade guide assembly as far as it will go. Turn the blade guide adjustment knob clockwise to retighten.
- Place a small combination square on the saw table beside the blade.
- Loosen the table lock knobs by turning counterclockwise and rotate the saw table up or down to align table 90° to blade (0° position).
- Retighten the table lock knobs by turning clockwise.
- Check squareness of the saw table to the blade. Make readjustments if necessary.
- Loosen screw on scale indicator with a Phillips screwdriver and align scale indicator to zero.
- Tighten all screws securely.

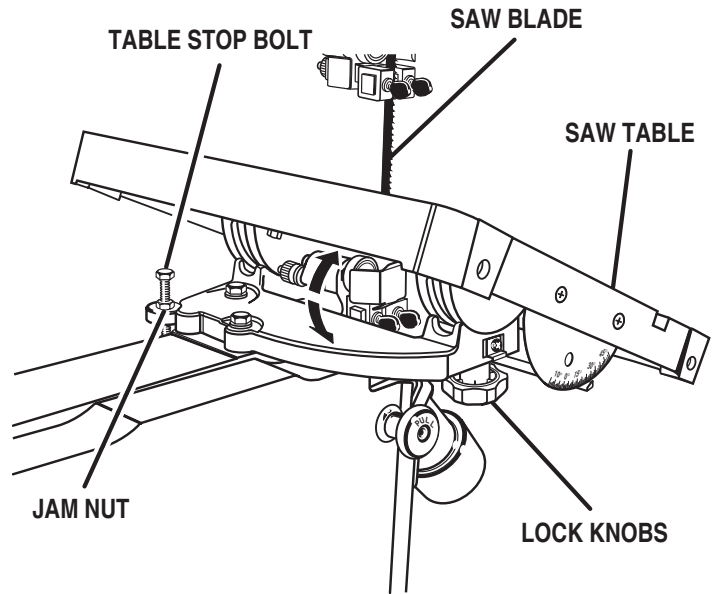
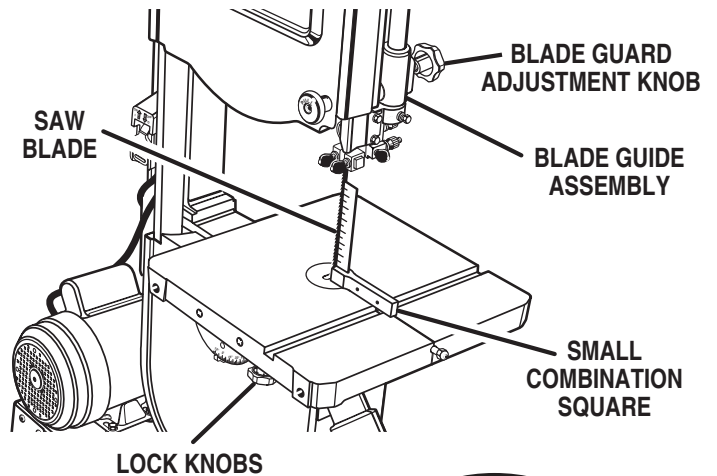

Fig. 30



ADJUST SCALE INDICATOR BACK TO 0° AFTER SQUARING BLADE TO TABLE

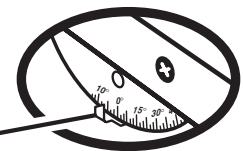

Fig. 31

ASSEMBLY

ADJUSTING UPPER BLADE GUIDE ASSEMBLY

See Figures 32 - 33.

- Unplug the saw and remove switch key.
- Loosen blade guard adjustment knob and raise or lower upper blade guide assembly to just above the material being cut.
- Tighten blade guard adjustment knob. Make sure blade guides are still flat to the blade. If adjustment is necessary, loosen blade guard adjustment knob and rotate assembly until blade guides are flat to the blade.
- The upper blade guide is spring loaded. To adjust the tension on the spring, remove blade guard adjustment knob, tighten or loosen set screw until desired tension is reached, and replace blade guard adjustment knob.

ADJUSTING UPPER BLADE GUIDES AND THRUST BEARING

See Figures 33 - 34.

⚠ WARNING:

Blade guard has been removed for picture clarity. Never operate the band saw without all guards in place and in working order. Failure to do so could result in possible serious personal injury.

- Unplug the saw and remove switch key.
- Blade must already be tensioned and tracking properly.
- Loosen thumb screws and move blade guides as close to the blade as possible without pinching it. The thickness of a dollar bill on each side of blade is a good rule of thumb.
- Tighten thumb screws.
- Loosen thumb screw and turn knurled knob to move the blade guide bracket in or out until the front edge of the blade guides are just behind the "gullets" of the saw teeth.
- Tighten thumb screw.
- Loosen thumb screw and turn knurled knob to move the thrust bearing in or out until the bearing is 1/64 in. behind the blade.
- Tighten thumb screw.
- Blade thrust bearing should be adjusted so that the back edge of the blade overlaps the front face of the ball bearing approximately 1/8 in. To change position of the bearing, remove screw bearing, and back off knurled knob completely to remove the bearing shaft. Notice the bearing holder on the shaft is eccentric. Reinstall the bearing shaft, the bearing, and the screw. Examine the overlap between the bearing face and the blade. Change the position of the bearing shaft until the overlap is approximately 1/8 in.

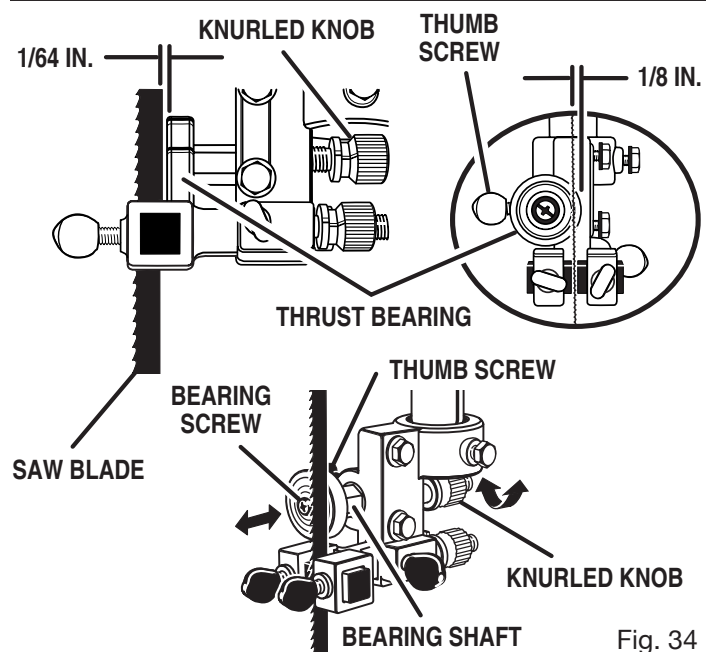
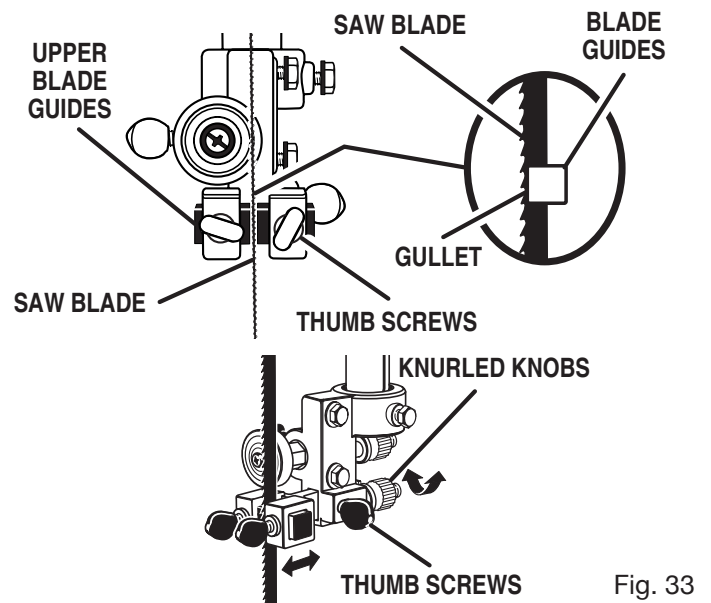
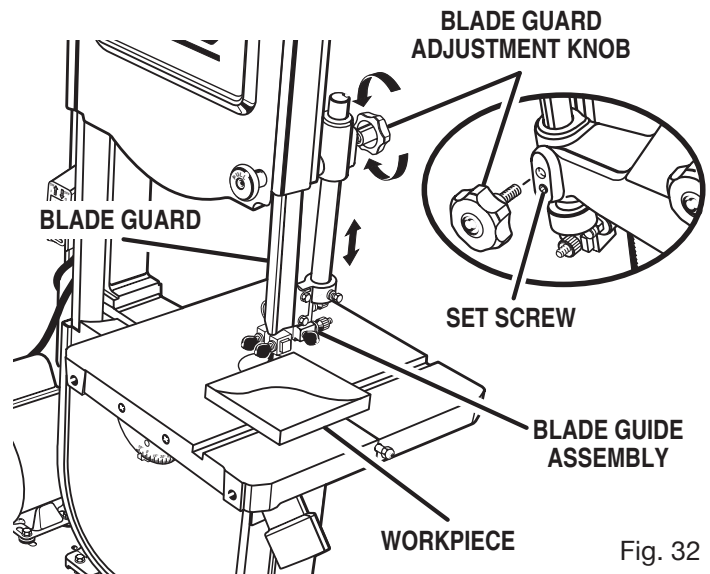

ASSEMBLY

ADJUSTING LOWER BLADE GUIDES AND THRUST BEARING

See Figures 35 - 36.

WARNING:

Saw table in drawing has been removed for clarity purposes. Never operate saw without all components in place and in working order. Failure to do so could result in possible serious personal injury.

- Disconnect machine from the power source and remove switch key.
- Blade must already be tensioned and tracking properly.
- Loosen thumb screws and move guide blocks as close to blade as possible without pinching it. The thickness of a dollar bill on each side of blade is a good rule of thumb.
- Tighten thumb screw.
- Loosen thumb screw and move the guide block support in or out until the front edge of the guide blocks are just behind the "gullets" of the saw teeth.
- Tighten thumb screw.
- Loosen thumb screw and move the thrust bearing in or out until it is 1/64 in. behind the saw blade
- Tighten thumb screw.
- The thrust bearing should be adjusted so that the back edge of the blade overlaps the front face of the ball bearing approximately 1/8 in. To change position of the bearing, remove screw and bearing. Loosen thumb screw and remove the bearing shaft. Notice the bearing holder on the shaft is eccentric. Reinstall the bearing shaft, the bearing, and the screw. Examine the overlap between the bearing face and the blade. Change the position of the bearing shaft until the overlap is approximately 1/8 in.

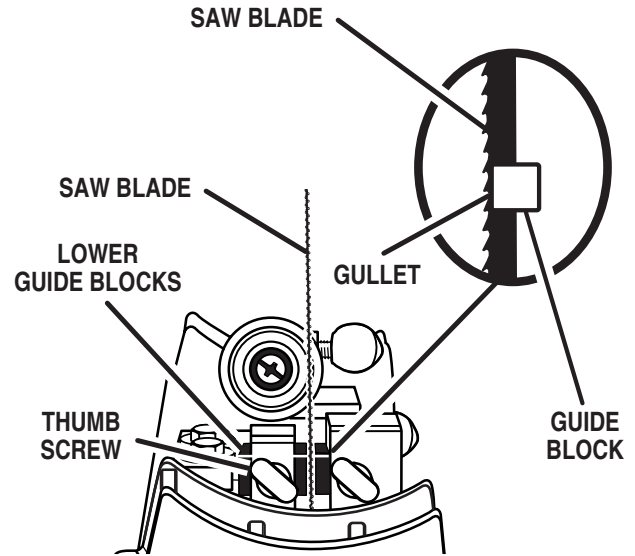

Fig. 35

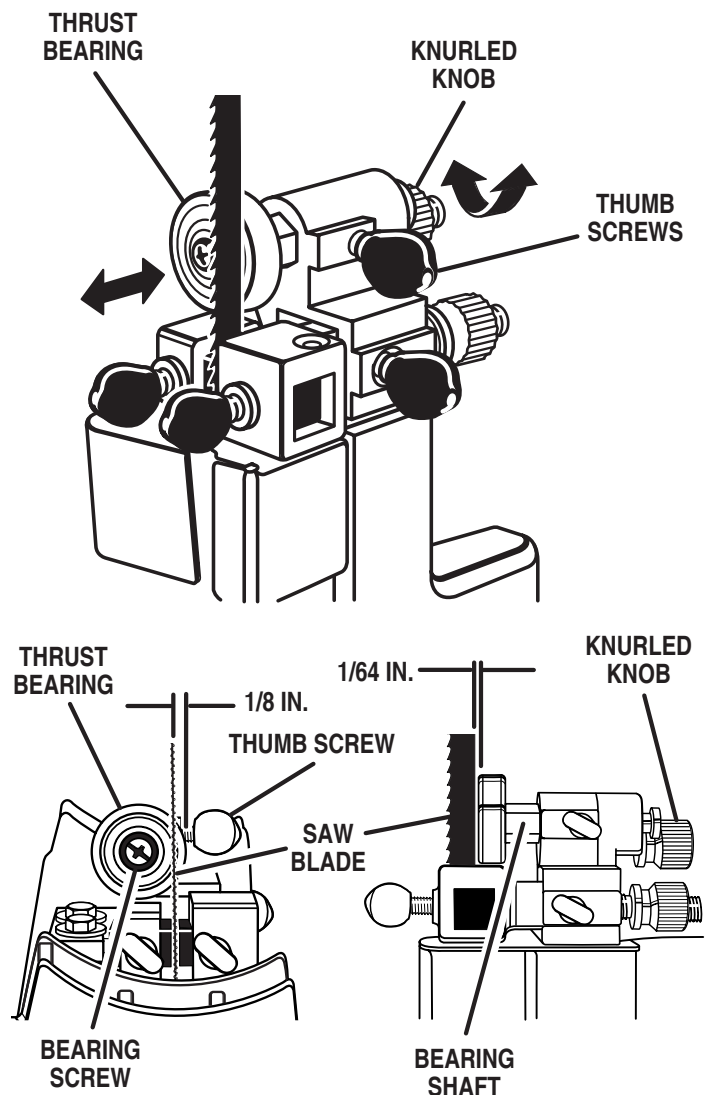

Fig. 36

OPERATION

WARNING:

Do not allow familiarity with tools to make you careless. Remember that a careless fraction of a second is sufficient to inflict severe injury.

WARNING:

Always wear safety goggles or safety glasses with side shields during power tool operation or when blowing dust. If operation is dusty, also wear a dust mask.

WARNING:

To avoid blade contact, adjust the blade guide assembly to just clear the workpiece. Failure to do so could result in serious personal injury.

APPLICATIONS

You may use this tool for the purposes listed below:

- Scroll cutting and circle cutting of wood and wood composition products
- Relief cutting of wood and wood composition products

BASIC OPERATION OF THE BAND SAW

A band saw is basically a “curve cutting” machine that can also be used for straight-line cutting operations like cross cutting, ripping, mitering, beveling, compound cutting, and resawing. It is not capable of making inside or non-through cuts.

This band saw is designed to cut wood and wood composition products only.

Before starting a cut, watch the saw run. If you experience excessive vibration or unusual noise, stop immediately. Turn the saw off, remove the switch key, and unplug the saw. Do not restart until locating and correcting the problem.

CUTTING PROCEDURES

- Hold the workpiece firmly against the saw table.
- Use gentle pressure and both hands when feeding the work into the blade. Do **not** force the work; allow the blade to cut.
- The smallest diameter circle that can be cut is determined by blade width. A 1/4 in. (6 mm) wide blade will cut a minimum diameter of 1-1/2 in. (38 mm); a 1/8 in. (3 mm) wide blade will cut a minimum diameter of 1/2 in. (13 mm).
- Keep your hands away from the blade. Do not hand hold pieces so small your fingers will go under the blade guard.

- Avoid awkward operations and hand positions where a sudden slip could cause serious injury from contact with the blade. Never place hands in blade path.
- Use extra supports (tables, saw horses, blocks, etc.) when cutting large, small or awkward workpieces.
- Never use a person as a substitute for a table extension or as additional support for a workpiece that is longer or wider than the basic saw table.
- When cutting irregularly shaped workpieces, plan your work so it will not pinch the blade. For example, a piece of molding must lay flat on the saw table. Workpieces must not twist, rock or slip while being cut.

When backing up the workpiece, the blade may bind in the kerf (cut). This is usually caused by sawdust clogging the kerf or when the blade comes out of the guides. If this happens:

- Wait until the saw has come to a full and complete stop.
- Place the switch in the **OFF (O)** position then remove the switch key from the switch assembly. Store key in a safe place.
- Unplug the saw from the power source.
- Wedge the kerf open with a flat screwdriver or wooden wedge.
- Open front cover and turn the upper wheel by hand while backing up the workpiece.

RELIEF CUTS

Relief cuts are made when an intricate curve (too small a radius for the blade) is to be cut. Cut through a scrap section of the workpiece to curve in pattern line then carefully back the blade out. Several relief cuts should be made for intricate curves before following the pattern line as sections are cutoff of curve “relieving” blade pressure.

SCROLL CUTTING

For general type scroll cutting, follow the pattern lines by pushing and turning the workpiece at the same time. Do not try to turn the workpiece while engaged in the blade without pushing it – the workpiece could bind or twist the blade.

REMOVING JAMMED MATERIAL

Never remove jammed cutoff pieces until the blade has come to a full and complete stop.

- Place the switch in the **OFF (O)** position, remove the switch key from the switch assembly.
- Unplug the saw from the power source before removing jammed material.

OPERATION

AVOIDING INJURY

- Make sure saw is level and does not rock. Saw should always be on a firm, level surface with plenty of room for handling and properly supporting the workpiece.
- Turn saw off, remove switch key, and unplug cord from the power source before moving the saw.
- Do not remove jammed cutoff pieces until blade has come to a full and complete stop.
- Choose the right size and style blade for the material and type of cut you plan to do.
- Make sure that the blade teeth point down toward the saw table, that the blade guides, thrust bearings, and blade tension are properly adjusted, that the blade guide knob is tight, and that no parts have excessive play.
- To avoid accidental blade contact, minimize blade breakage, and provide maximum blade support, always adjust the blade guide assembly to just clear the workpiece.
- Use only recommended accessories.
- With the exception of the workpiece and related support devices, clear everything off the saw table before turning the saw on.
- Properly support round materials such as dowel rods or tubing because they have a tendency to roll during a cut causing the blade to “bite”. To avoid this, always use a “V” block or clamp workpiece to a miter gauge
- Before removing loose pieces from the saw table, turn saw off and wait for all moving parts to stop.

LOCKING THE SWITCH

See Figure 37.

- Wait until the saw has come to a full and complete stop.
- Place the switch in the **OFF (O)** position, remove the switch key from the switch assembly. Store key in a safe place.

BEFORE LEAVING THE SAW

See Figure 37.

- Wait until the saw has come to a full and complete stop.
- Place the switch in the **OFF (O)** position, remove the switch key from the switch assembly. Store key in a safe place.
- Unplug the saw from the power source.

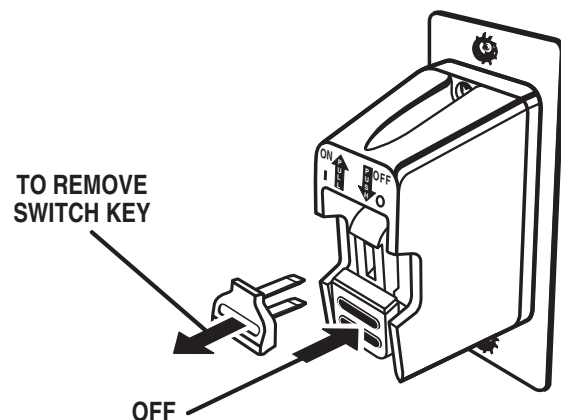
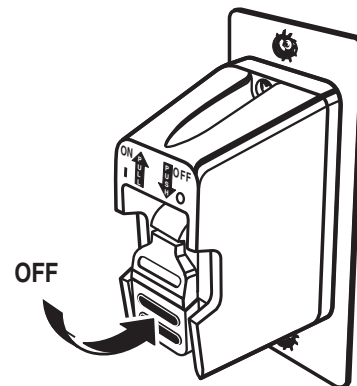
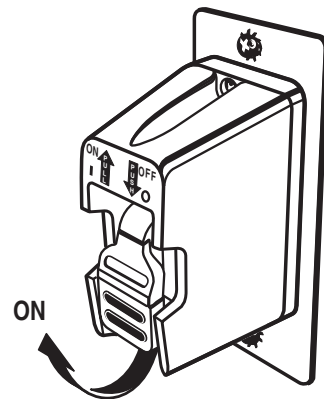
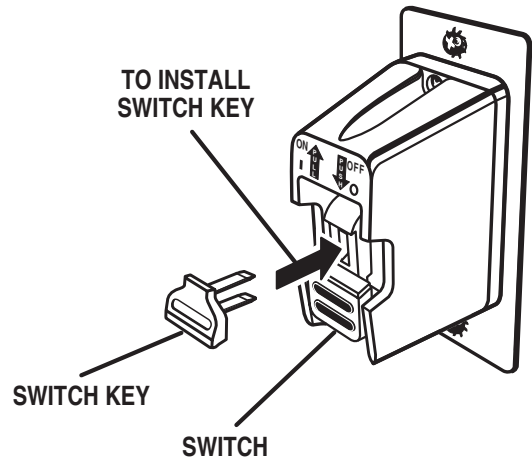

Fig. 37

OPERATION

TILTING THE TABLE

See Figure 38.

- Loosen the lock knob slightly.
- Turn the angle adjustment knob, tilt the saw table toward the front of the saw housing until it reaches the desired angle.
- Using the scale indicator, check angle markings.
- Retighten the lock knob to hold saw table securely in place.

CIRCLE CUTTING

See Figure 39.

- Adjust the upper guides to vertically just clear the workpiece.
- Use both hands while feeding the work into the blade. Hold the workpiece firmly against the table. Use gentle pressure, and do not force the work, but allow the blade to cut.
- The smallest diameter that can be cut out is determined by the width of the blade. For example, a 1/4 in. (6 mm) wide blade will cut a minimum diameter of approximately 1-1/2 in. (38 mm).

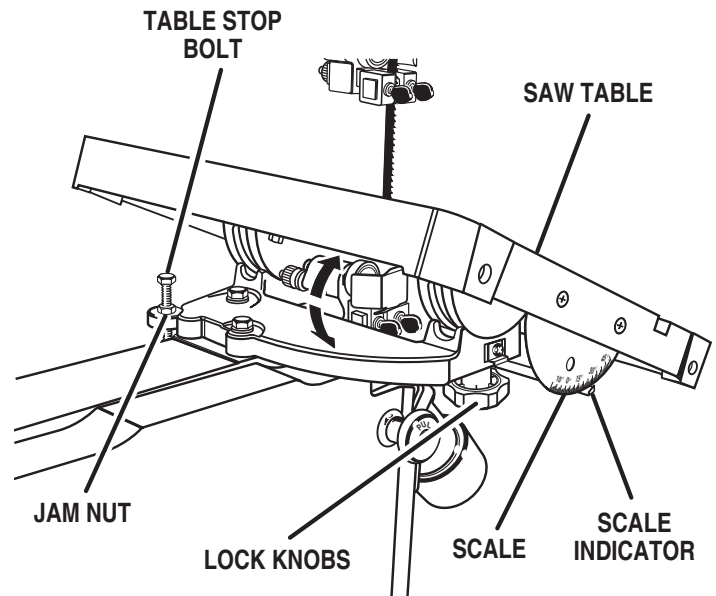

Fig. 38

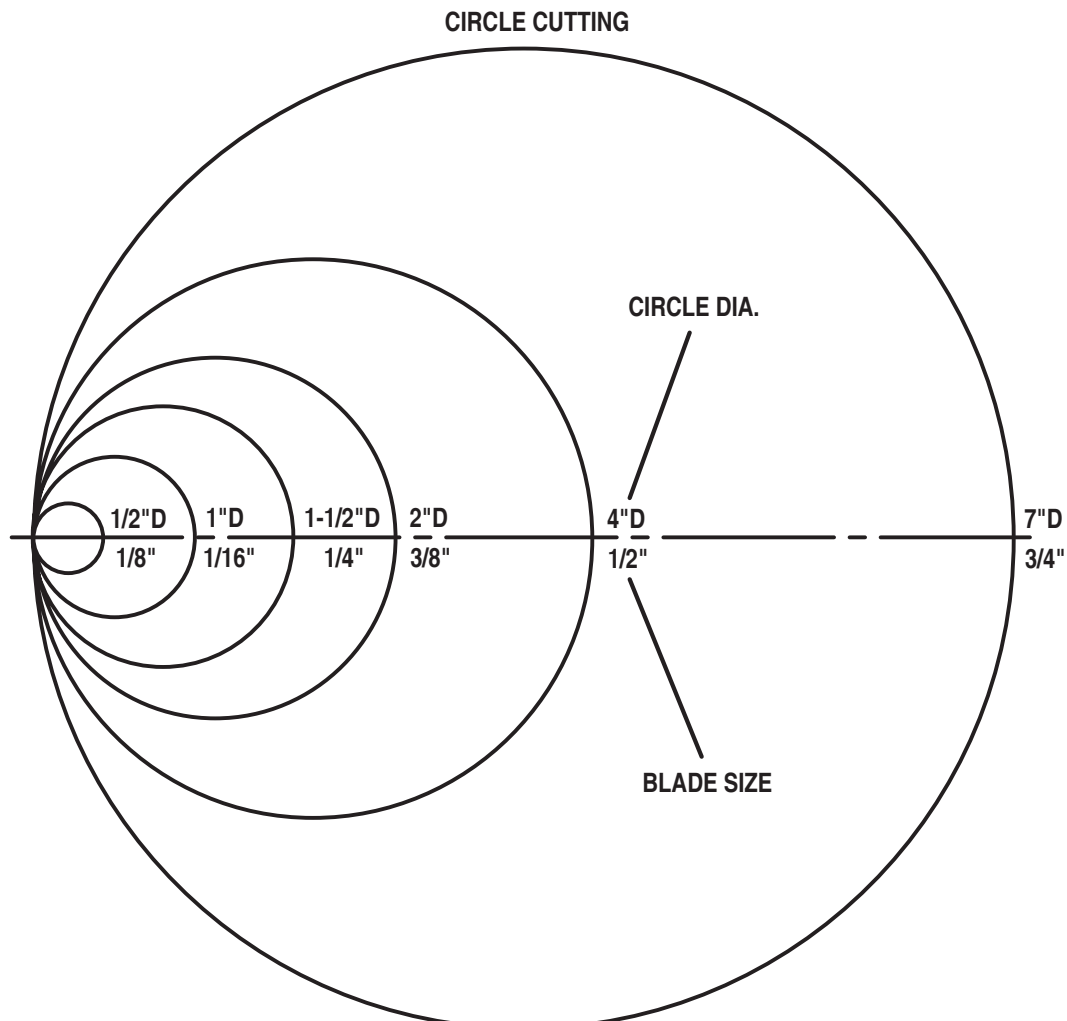

Fig. 39

ADJUSTMENTS

⚠ WARNING:

Failure to turn the saw off, remove the switch key, and unplug the saw could result in accidental starting causing possible serious personal injury.

⚠ WARNING:

Always wear safety goggles or safety glasses with side shields to protect your eyes while uncoiling band saw blades. Failure to do so could result in possible serious personal injury.

INSTALLING AND ADJUSTING THE BLADE

See Figures 40 - 41.

- Turn the saw off, remove the switch key, and unplug the saw from the power source.
- Remove the table pin and the throat plate from the saw table.
- Turn the blade guard adjustment knob counterclockwise to unlock the blade guide assembly. Raise the blade guide assembly as high as it will go. Turn the blade guard adjustment knob clockwise to retighten.
- Turn the blade tension knob counterclockwise to release tension on the blade.
- Insert screwdriver through table insert hole to loosen the screw holding the guard under the saw table. Rotate guard out of the way.
- Open the upper and lower cover by pulling on the knobs.
- Remove the screws and clamps from the rear blade guard. Remove rear blade guard.
- Wearing gloves, carefully remove the old blade. Turn the blade to pass through the slot in the saw table.
- Carefully uncoil the new blade at arms length. If the new blade was oiled to prevent rusting, it may need to be wiped to keep the oil from your workpiece. Carefully wipe in the same direction the teeth are pointing so the rag does not catch on the teeth of the blade.

NOTE: The blade may need to be turned inside out if the teeth are pointing in the wrong direction. Hold the blade with both hands and rotate it inward.

- With the teeth of the blade toward the front of the saw and facing downward, slide the blade through the saw table slot.
- Place blade in the upper and lower blade guides, and over the upper wheel and under the lower wheel.
- Turn the blade tension knob clockwise to tension the blade. See **Assembly** section "Adjusting Blade Tension".
- Adjust the tracking of the blade. See **Assembly** section "Tracking the Blade".
- Replace rear blade guard. Secure with screws and clamps.

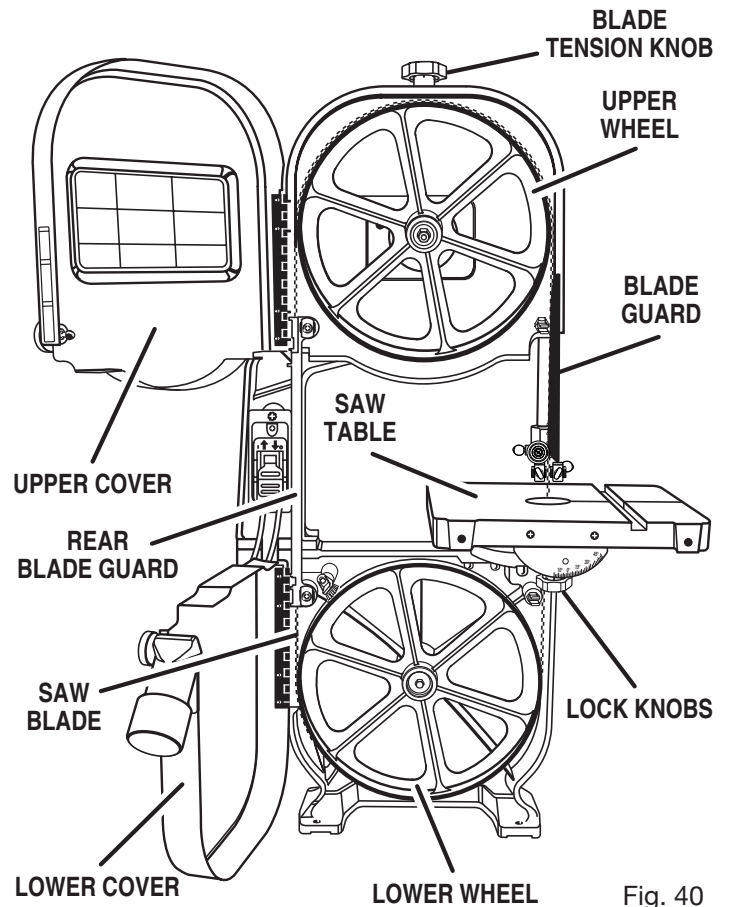

Fig. 40

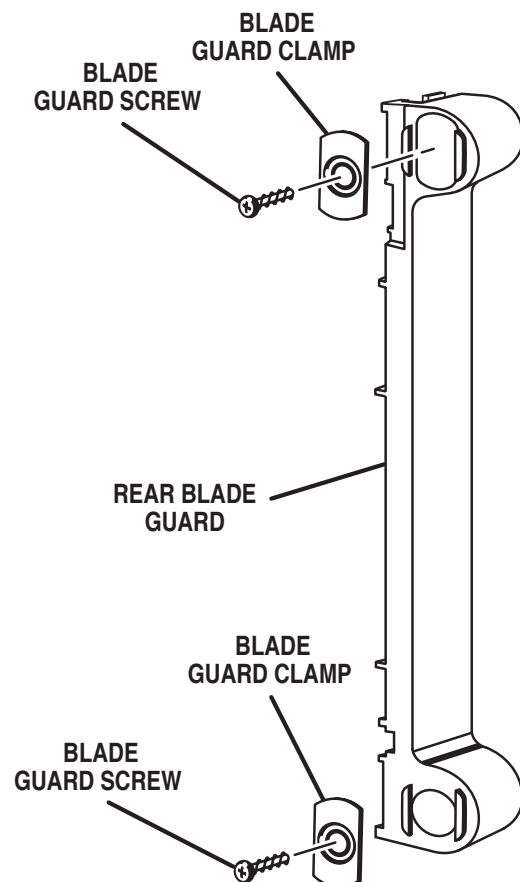

Fig. 41

ADJUSTMENTS

- Rotate guard under the saw table back to a closed position and tighten screw.
- Close upper and lower covers.
- Replace throat plate and table pin.
- Adjust blade guide assembly as described in the following section.

ADJUSTING BLADE GUIDE ASSEMBLY

See Figure 42.

To prevent the blade from twisting or breaking, the blade guide assembly should always be set approximately 1/8 in. (3 mm) above the workpiece.

- Turn the blade guard adjustment knob counterclockwise to unlock the blade guide assembly.
- As a guide, use a scrap piece of the same wood you are about to cut to set the height of the blade guide assembly. Adjust the blade guide assembly by raising or lowering.
- Lock blade guide assembly in place by turning the blade guard adjustment knob clockwise.
- Always lock the blade guide assembly in place before turning on the band saw.

WARNING:

Maintain proper adjustment of blade tension, blade guides, and thrust bearings. Failure to do so could result in possible serious personal injury.

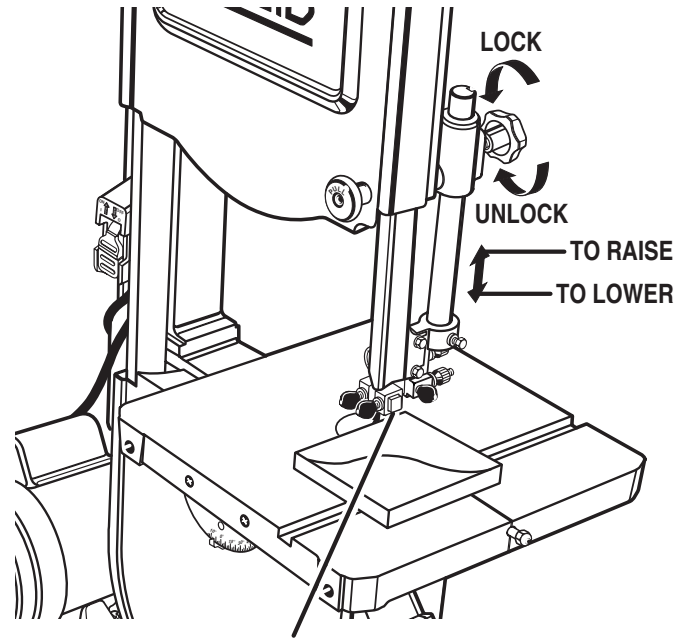

SET BLADE GUIDE ASSEMBLY APPROXIMATELY
1/8IN. (3 MM) ABOVE WORKPIECE

Fig. 42

MAINTENANCE

WARNING:
When servicing, use only identical RIDGID replacement parts. Use of any other parts may create a hazard or cause product damage.

WARNING:
Always wear safety goggles or safety glasses with side shields during power tool operation or when blowing dust. If operation is dusty, also wear a dust mask.

WARNING:
To prevent accidental starting that could cause possible serious personal injury, turn off the saw, remove the switch key, and unplug the saw before working on the band saw.

GENERAL MAINTENANCE

Avoid using solvents when cleaning parts. Most plastics are susceptible to damage from various types of commercial solvents and may be damaged by their use. Use clean cloths to remove dirt, carbon dust, etc.

WARNING:
Do not, at any time, let brake fluids, gasoline, petroleum-based products, penetrating oils, etc., come in contact with plastic parts. They contain chemicals that can damage, weaken or destroy plastic.

- Keep your band saw clean.
- Remove sawdust from the inside frequently.
- Do not allow pitch to accumulate on the saw table, blade guides, or thrust bearings. Clean them with gum and pitch remover.
- Apply a thin coat of automobile type wax to the saw table's top so the wood slides easily while cutting.

MOTOR/ELECTRICAL

- Frequently vacuum or blow out sawdust from the motor.
-

WARNING:
If the power cord is worn, cut or damaged in any way, have it replaced immediately by a qualified service technician. Failure to do so could result in serious personal injury.

WARNING:
To avoid fire or electrocution, reassemble electric parts with only identical replacement parts. Reassemble exactly as originally assembled.

TIRES

Cleaning Tires:

- Pitch and sawdust accumulates on tires and needs to be removed with a fine wire brush or a piece of wood. **Do not** use a sharp knife or any kind of solvent.

Replacing Tires:

- Open front cover and remove saw blade. See section on Installing and Adjusting the Blade, page 28.
- Pry the worn tire away from the wheel carefully.
- Stretch the new tire around the wheel.
- Replace the saw blade and close the front cover.

BLADE GUIDES

See Figure 34.

- Blade guides may become rounded and worn during use. Remove the blade guides and file or grind flat.
- Replace blade guides when filing or grinding has worn them down and they can no longer be properly secured in place.

MAINTENANCE

LUBRICATION

All the bearings in this tool are lubricated with a sufficient amount of high grade lubricant for the life of the unit under normal operating conditions. Therefore no further lubrication is required.

BRUSH

See Figure 43.

There is a brush located inside the saw housing, next to the lower wheel. It helps protect the tire and wheel by brushing off saw dust. As the brush becomes worn, it will need to be adjusted or replaced.

- Remove the screw then pull the brush off.
- Place the new brush in the groove.
- Retighten using the screw.

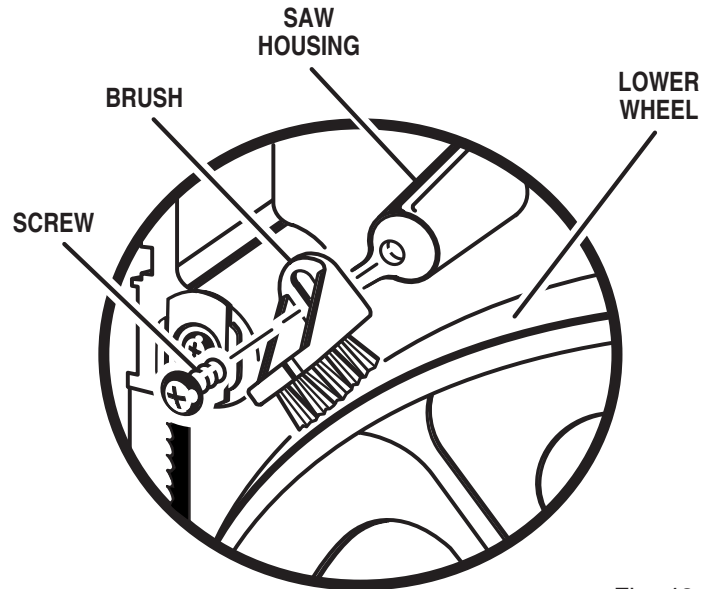

Fig. 43

ACCESSORIES

Item	Part No.
Rip Fence	AC5001
Riser Block	AC5005
Sanding Belts	AC5006
Cool Blocks™	AC5007
Miter Gauge.....	AC1021
Herc-U-Lift PLUS™.....	AC9950

⚠ WARNING:
 Current attachments and accessories available for use with this tool are listed above. Do not use any attachments or accessories not recommended by the manufacturer of this tool. The use of attachments or accessories not recommended can result in serious personal injury.

TROUBLESHOOTING

Problem	Cause	Solution
Excessive noise	Motor	Have motor checked by qualified service technician. Repair service is available your nearest Authorized Service Center store.
Motor fails to develop full power. NOTE: Low Voltage Power output of motor decreases rapidly with decrease in voltage at motor terminals. For example, a reduction of 10% in voltage causes a reduction of 19% in maximum power output of which the motor is capable, and a reduction of 20% in voltage causes a reduction of 36% in maximum power output	Circuit overloaded with light, appliances and other motors. Under size wires or circuit too long. General overloading of power company facilities.	Do not use other appliances or motors on same circuit when using the saw. Increase wire sizes, or reduce length of wiring. See Electrical section. Request a voltage check from the power company.
Motor starts slowly or fails to come up to full speed	Motor overloaded. Improper cooling (air circulation restricted through motor due to sawdust accumulation)	Feed work slower into blade. Clean out sawdust to provide normal air circulation through motor. See Maintenance section.
Starting switch in motor will not operate.	Burned switch contacts (due to extended hold-in periods caused by low line voltage, etc.) Shorted capacitor. Loose or broken connections.	Have switch replaced and request a voltage check from the power company. Have capacitor tested and replace if defective. Have wiring checked and repaired.

TROUBLESHOOTING

Problem	Cause	Solution
Motor stalls (resulting in blown fuses or tripped circuit breakers).	Starting switch not operating.	Have switch replaced.
	Voltage too low to permit motor to reach operating speed.	Request voltage check from the power company.
	Fuses or circuit breakers do not have sufficient capacity	Install proper size fuses or circuit breakers.
Frequent opening of fuses or circuit breakers.	Motor overloaded.	Feed work slower into blade.
	Fuses or circuit breakers do not have sufficient capacity.	Install proper size fuses or circuit breakers. Check that wiring will handle load.
	Starting switch not operating (motor does not reach speed)	Have switch replaced. Blow out sawdust.
Blade does not run in the approximate center of the upper wheel.	Not tracking properly.	Adjust tracking, see Assembly section, "Tracking the Blade" section.
Band Saw slows down when cutting.	Belt too loose.	Adjust belt tension, see Assembly section, "Mounting the Motor Assembly".
	Cutting too small a radius.	Stop feeding, and back up the material slightly, until the band saw speeds up.
	Dull blade.	Replace blade.
	Overloading motor.	Slow down, trying to cut too fast.
Blades breaking	Too much tension on blade.	Adjust tension. See Assembly section, "Adjusting Blade Tension".
	Kink in blade caused cutting too small a radius or turning the material too fast when cutting.	Use correct cutting technique. See Operation section.
Blade dulls too quickly.	Blade guides set too close to teeth.	Adjust upper and lower blades guides. See Assembly section "Installing and Adjusting the blade".
	Cutting incorrect material.	
Band saw vibrates.	Too much tension on motor belt.	Adjust according to "Mounting the Motor Assembly" section.

WARRANTY

RIDGID® HAND HELD AND STATIONARY POWER TOOL 3 YEAR LIMITED SERVICE WARRANTY

Proof of purchase must be presented when requesting warranty service.

Limited to RIDGID® hand held and stationary power tools purchased 2/1/04 and after. This product is manufactured by One World Technologies, Inc. The trademark is licensed from RIDGID, Inc. All warranty communications should be directed to One World Technologies, Inc., attn: RIDGID Hand Held and Stationary Power Tool Technical Service at (toll free) 1-866-539-1710.

90-DAY SATISFACTION GUARANTEE POLICY

During the first 90 days after the date of purchase, if you are dissatisfied with the performance of this RIDGID® Hand Held and Stationary Power Tool for any reason you may return the tool to the dealer from which it was purchased for a full refund or exchange. To receive a replacement tool you must present proof of purchase and return all original equipment packaged with the original product. The replacement tool will be covered by the limited warranty for the balance of the 3 YEAR service warranty period.

WHAT IS COVERED UNDER THE 3 YEAR LIMITED SERVICE WARRANTY

This warranty on RIDGID® Hand Held and Stationary Power Tools covers all defects in workmanship or materials and normal wear items such as brushes, chucks, motors, switches, cords, gears and even cordless batteries in this RIDGID® tool for three years following the purchase date of the tool. Warranties for other RIDGID® products may vary.

HOW TO OBTAIN SERVICE

To obtain service for this RIDGID® tool you must return it; freight prepaid, or take it in to an authorized service center for RIDGID® branded hand held and stationary power tools. You may obtain the location of the authorized service center nearest you by calling (toll free) 1-866-539-1710 or by logging on to the RIDGID® website at www.ridgid.com. When requesting warranty service, you must present the original dated sales receipt. The authorized service center will repair any faulty workmanship, and either repair or replace any part covered under the warranty, at our option, at no charge to you.

WHAT IS NOT COVERED

This warranty applies only to the original purchaser at retail and may not be transferred. This warranty only covers defects arising under normal usage and does not cover any malfunction, failure or defect resulting from misuse, abuse, neglect, alteration, modification or repair by other than an authorized service center for RIDGID® branded hand held and stationary power tools. Consumable accessories provided with the tool such as, but not limited to, blades, bits and sand paper are not covered.

RIDGID, INC. AND ONE WORLD TECHNOLOGIES, INC. MAKE NO WARRANTIES, REPRESENTATIONS OR PROMISES AS TO THE QUALITY OR PERFORMANCE OF ITS POWER TOOLS OTHER THAN THOSE SPECIFICALLY STATED IN THIS WARRANTY.

ADDITIONAL LIMITATIONS

To the extent permitted by applicable law, all implied warranties, including warranties of MERCHANTABILITY or FITNESS FOR A PARTICULAR PURPOSE, are disclaimed. Any implied warranties, including warranties of merchantability or fitness for a particular purpose, that cannot be disclaimed under state law are limited to three years from the date of purchase. One World Technologies, Inc. and Ridgid, Inc. are not responsible for direct, indirect, incidental or consequential damages. Some states do not allow limitations on how long an implied warranty lasts and/or do not allow the exclusion or limitation of incidental or consequential damages, so the above limitations may not apply to you. This warranty gives you specific legal rights, and you may also have other rights which vary from state to state.

One World Technologies, Inc.

Hwy. 8

Pickens, SC 29671

OPERATOR'S MANUAL

14 in. BAND SAW

BS14002

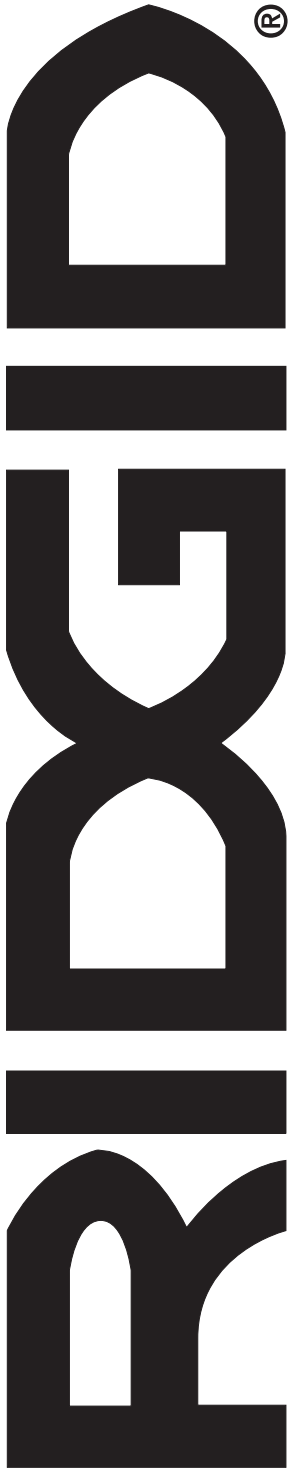

CUSTOMER SERVICE INFORMATION

For parts or service, contact your nearest Ridgid authorized service center. Be sure to provide all relevant information when you call or visit. For the location of the authorized service center nearest you, please call 1-866-539-1710 or visit us online at www.ridgid.com.

The model number of this tool is found on a plate attached to the motor housing. Please record the serial number in the space provided below. When ordering repair parts, always give the following information:

Model No. BS14002

Serial No. _____

Free Manuals Download Website

<http://myh66.com>

<http://usermanuals.us>

<http://www.somanuals.com>

<http://www.4manuals.cc>

<http://www.manual-lib.com>

<http://www.404manual.com>

<http://www.luxmanual.com>

<http://aubethermostatmanual.com>

Golf course search by state

<http://golfingnear.com>

Email search by domain

<http://emailbydomain.com>

Auto manuals search

<http://auto.somanuals.com>

TV manuals search

<http://tv.somanuals.com>