

Tanaka

Parts Catalog

Hedge Trimmer

Model: THT-230

Serial No. -J243610

FIG. 1 ENGINE

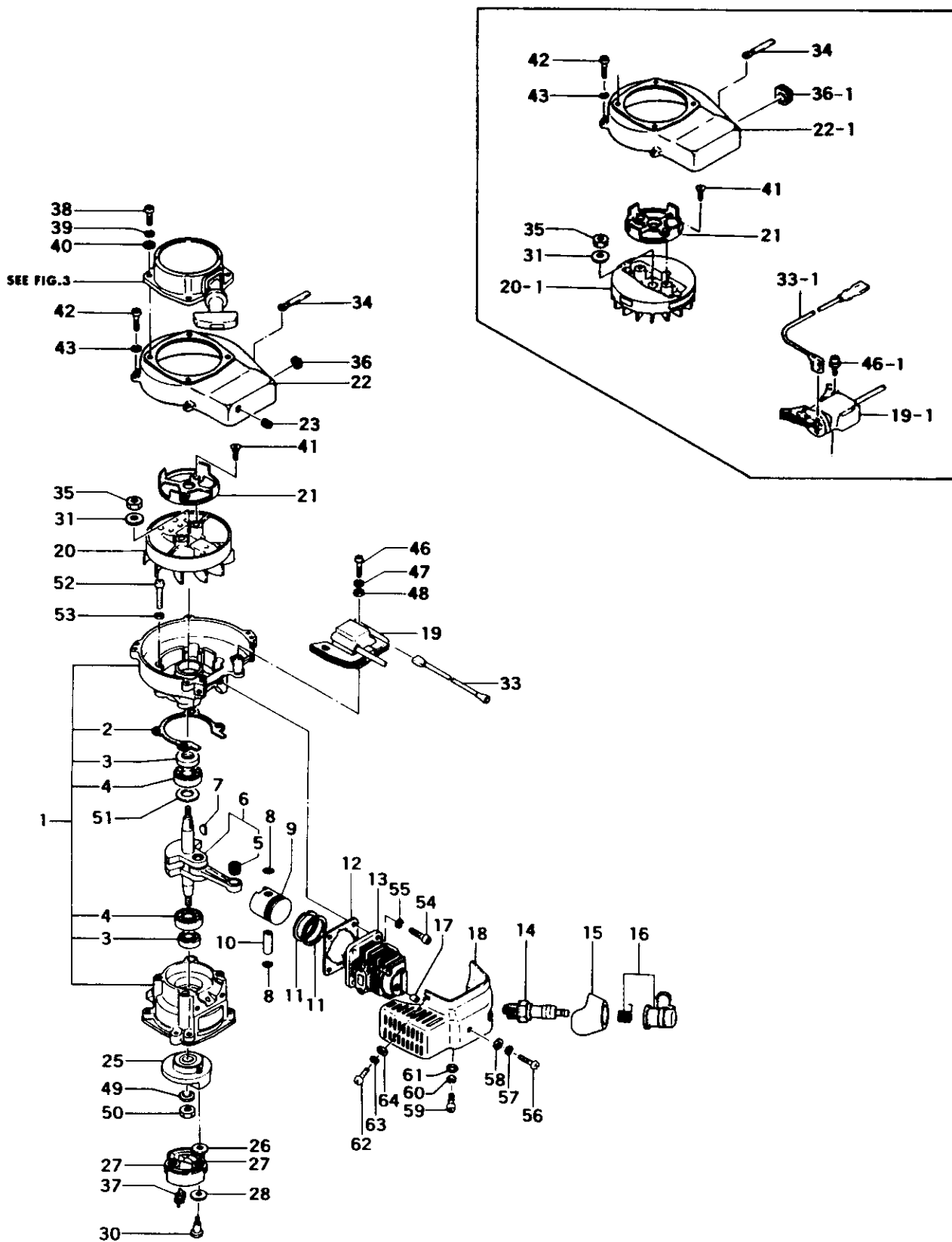

REF. NBR	PART NBR	PART NAME	QTY	SERIAL NBR	REMARKS
1-001	072-0639T-900	CRANK CASE ASS'Y	1	-G076701	
1-001	072-0639T-910	CRANK CASE ASS'Y	1	G076702-	
1-002	090-08000-202	CRANK CASE GASKET	1		
1-003	999-66122-266	OIL SEAL 12227	2		
1-004	999-61600-100	BALL BEARING #6001, 28MM/OD	2		
1-005	999-62071-127	NEEDLE BEARING F-79	1		
1-006	046-0639V-801	CRANK SHAFT COMP.	1	R -G076701	
1-006	046-0639V-802	CRANK SHAFT COMP.	1	G076702-	
1-007	068-10100-200	WOOD-RUFF KEY 3X13X4.5	1		
1-008	039-06100-200	CIR CLIP	2		
1-009	031-06097-201	PISTON	1	R -G076701	
1-009	031-06320-200	PISTON	1	G076702-	
1-010	037-06097-200	PISTON PIN	1		
1-011	041-00000-200	PISTON RING	2	I -H242200	
1-011	041-00000-210	PISTON RING	2	H242201-	
1-012	017-06091-201	CYLINDER GASKET	1		
1-013	002-06092-803	CYLINDER COMP.	1		
1-014	018-01805-200	SPARK PLUG CJ8	1		
1-015	255-0630G-210	SPARK PLUG RUBBER COVER	1		
1-016	157-11666-900	SPARK PLUG CAP ASS'Y	1		
1-017	011-0630B-200	CYLINDER COVER COLLAR	1		
1-018	738-0632R-201	MUFFLER PROTECTOR	1		
1-019, 1	167-21852-800	IGNITION COIL COMP.	1	-G076701	
1-019	167-20508-800	IGNITION COIL COMP.	1	N G076702-	
1-020, 1	155-21718-800	MAGNETO ROTOR COMP.	1	-G076701	
1-020	155-20512-800	MAGNETO ROTOR COMP.	1	N G076702-	
1-021	798-0639V-200	STARTER PULLEY	1		
1-022, 1	112-0639V-200	FAN CASE	1	-G076701	
1-022	112-0639A-210	FAN CASE	1	N G076702-	
1-023	202-01003-201	SECONDARY CORD GROMMET	1	N G076702-	
1-025	347-0639V-800	CLUTCH FLANGE COMP.	1	R -G076701	
1-025	347-0639V-801	CLUTCH FLANGE COMP.	1	G076702-	
1-026	359-02103-200	CLUTCH WASHER B	2		
1-027	290-00501-802	CLUTCH SHOE COMP.	2	-G076701	
1-027	290-01620-800	CLUTCH SHOE COMP.	2	N G076702-	
1-028	358-02103-200	WASHER	2		
1-030	357-00601-200	STEP BOLT	2	-G076701	
1-030	357-0075T-200	STEP BOLT	2	N G076702-	
1-031	065-00000-200	FLYWHEEL WASHER	1		
1-033, 1	178-0136W-800	STOP CORD COMP.	1	R -G076701	
1-033	178-0639A-800	STOP CORD COMP.	1	G076702-	
1-034	198-05015-800	CORD CLAMP COMP.	1		
1-035	327-00201-200	NUT 7 (L. H. THREAD)	1	I -G076701	
1-035	327-00201-201	NUT 7 (L. H. THREAD)	1	G076702-	
1-036, 1	203-0604A-202	GROMMET	1	-G076701	
1-036	203-0639A-200	GROMMET	1	N G076702-	
1-037	342-00501-204	CLUTCH SPRING	1	-G076701	
1-037	342-0630B-200	CLUTCH SPRING	1	P G076702-	
1-038	990-11040-121	SCREW 4X12	4		
1-039	992-10040-012	S. WASHER 4	4		
1-040	992-01040-011	WASHER 4	4		
1-041	990-12060-151	F. H. SCREW 6X15	2		
1-042	990-11050-161	SCREW 5X16	4		
1-043	992-10050-012	S. WASHER 5	4		
1-046, 1	994-16040-226	SCREW 4X22/WS	2	-G076701	
1-046	990-11050-201	SCREW 5X20	2	N G076702-	
1-047	992-10050-012	S. WASHER 5	2	N G076702-	
1-048	992-00050-011	SMALL WASHER 5	2	N G076702-	
1-049	992-10080-012	S. WASHER 8	1	N	
1-049	992-00080-011	SMALL WASHER 8	1		
1-050	991-16080-003	NUT 8 (L.H. THREAD)	1		
1-051	330-00200-210	GEAR SHAFT SHIM 0.10	V		
1-051	330-00200-220	GEAR SHAFT SHIM 0.15	V		

- To be cont'd -

REF. NBR	PART NBR	PART NAME	QTY	SERIAL NBR	REMARKS
1-051	330-00200-230	GEAR SHAFT SHIM 0.20	V		
1-051	330-00200-240	GEAR SHAFT SHIM 0.30	V		
1-052	990-11050-301	SCREW 5X30	4		
1-053	992-10050-012	S. WASHER 5	4		
1-054	990-11050-201	SCREW 5X20	4		
1-055	992-10050-012	S. WASHER 5	4		
1-056	990-11050-181	SCREW 5X18	1		
1-057	992-10050-012	S. WASHER 5	1		
1-058	992-01050-011	WASHER 5	1		
1-059	990-11050-121	SCREW 5X12	1		
1-060	992-10050-012	S. WASHER 5	1		
1-061	992-01050-011	WASHER 5	1		
1-062	990-11040-121	SCREW 4X12	1		
1-063	992-10040-012	S. WASHER 4	1		
1-064	992-01040-011	WASHER 4	1		

FIG.2 ENGINE COMPONENTS

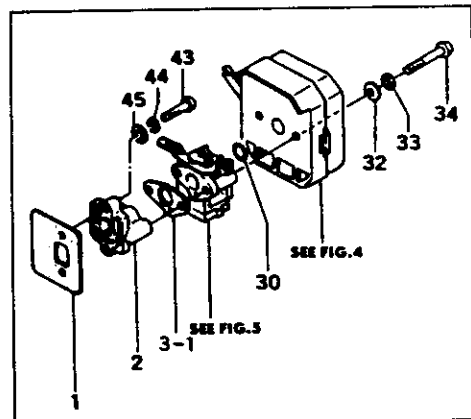
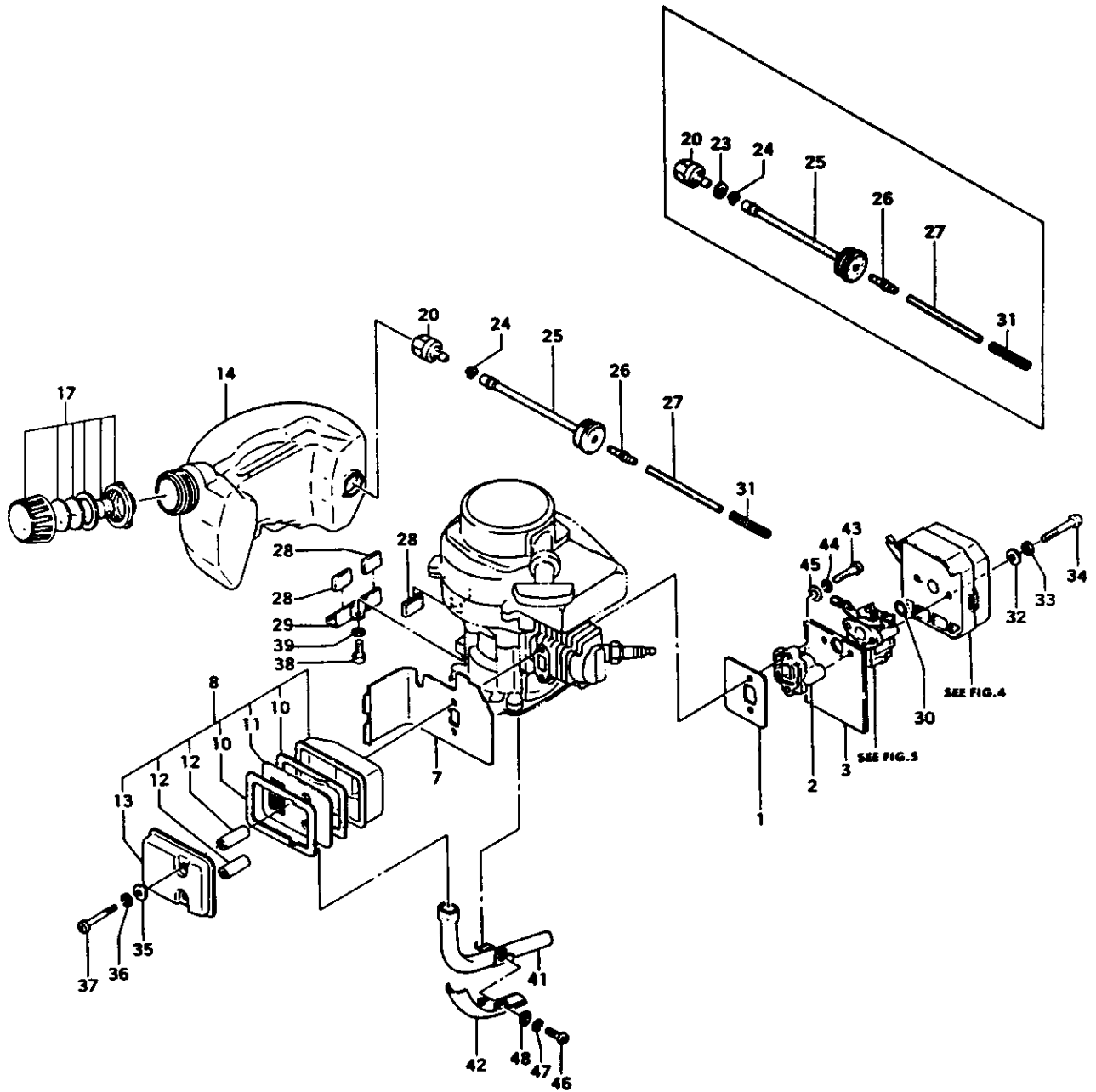

REF. NBR	PART NBR	PART NAME	QTY	SERIAL NBR	REMARKS
2-001	403-0602K-201	INLET MANIFOLD GASKET	1		
2-002	404-0639W-801	CARBURETOR INSULATOR COMP.	1	R -G234770	
2-002	404-0639W-802	CARBURETOR INSULATOR COMP.	1	G234771-	
2-003, 1	402-0602K-200	CARBURETOR GASKET	1	R -G234770	
2-003	402-0639W-200	CARBURETOR GASKET	1	G234771-	
2-007	133-0602K-204	HEAT SHIELD	1		
2-008	706-0639T-900	MUFFLER ASS'Y	1		
2-010	739-0602B-200	MUFFLER COUPLING GASKET	2		
2-011	722-0602B-800	MUFFLER PARTITION PLATE COMP.	1		
2-012	740-0602B-201	MUFFLER COLLAR	2		
2-013	717-0639T-800	MUFFLER BODY B COMP.	1		
2-014	591-0639W-201	TANK	1		
2-017	595-0062A-901	TANK CAP ASS'Y	1		
2-020	675-06020-900	PUMP FILTER BODY ASS'Y	1	I -G234770	
2-020	675-11600-900	PUMP FILTER BODY ASS'Y	1	G234771-	
2-023	992-01050-011	WASHER 5	1	D G234771-	
2-024	680-04019-210	CLIP 7	1		
2-025	678-0602W-200	RUBBER PIPE	1		
2-026	497-32350-200	PIPE JOINT	1		
2-027	700-03005-110	FUEL PIPE 3X5X110	1		
2-028	655-06100-200	FUEL TANK CUSHION RUBBER	4		
2-029	653-06000-200	FUEL TANK BRACKET	1		
2-030	431-0602K-200	AIR CLEANER GASKET	1		
2-031	702-02004-200	FUEL PIPE COIL	1		
2-032	992-00050-011	SMALL WASHER 5	2		
2-033	992-10050-012	S. WASHER 5	2		
2-034	990-11050-701	SCREW 5X70	2	M	
2-034	990-11050-451	SCREW 5X45	2		
2-035	992-01050-011	WASHER 5	2		
2-036	992-10050-012	S. WASHER 5	2		
2-037	990-11050-421	SCREW 5X42	2		
2-038	990-11050-141	SCREW 5X14	1		
2-039	992-10050-012	S. WASHER 5	1		
2-041	721-0639T-800	TAIL PIPE COMP.	1		
2-042	752-0639T-200	MUFFLER PROTECTOR B	1		
2-043	990-11050-221	SCREW 5X22	2	M	
2-043	990-11050-241	SCREW 5X24	2		
2-044	992-10050-012	S. WASHER 5	2		
2-045	992-00050-011	SMALL WASHER 5	2		
2-046	990-11040-101	SCREW 4X10	1		
2-047	992-10040-012	S. WASHER 4	1		
2-048	992-01040-011	WASHER 4	1		

FIG.3 RECOIL STARTER

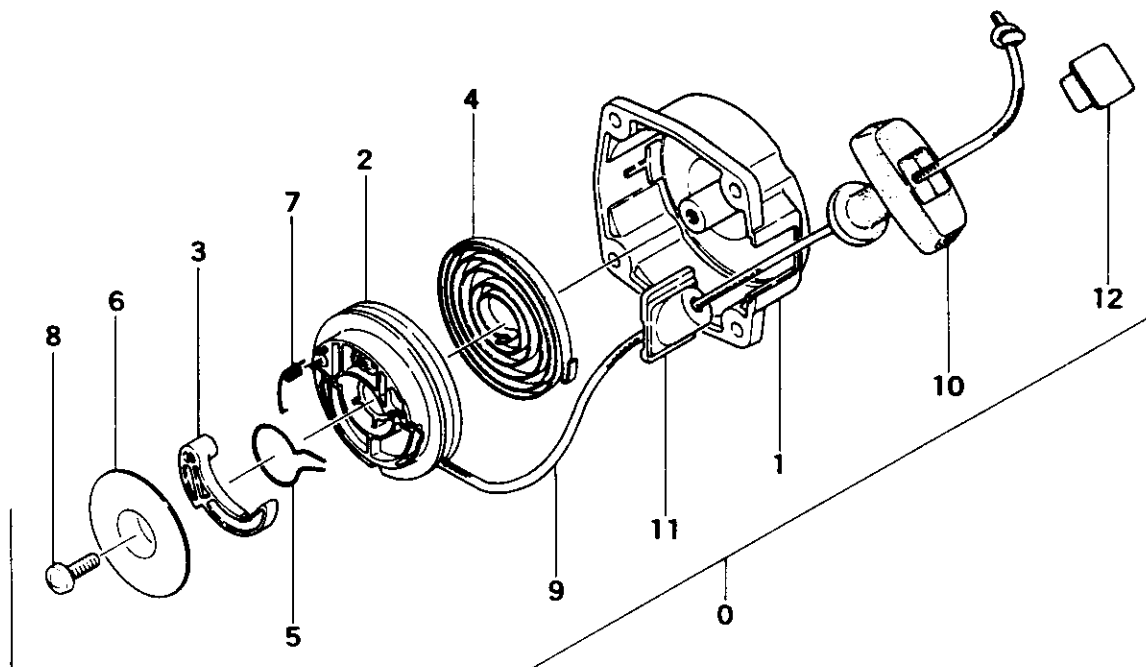

REF. NBR	PART NBR	PART NAME	QTY	SERIAL NBR	REMARKS
3-000	762-06150-901	RECOIL STARTER BODY ASS'Y	1		
3-001	772-06150-200	RECOIL STARTER BODY	1		
3-002	769-01250-200	STARTER ROPE REEL	1		
3-003	788-01250-200	STARTER PAWL	1		
3-004	779-01250-200	RECOIL SPRING	1		
3-005	836-06092-200	FRICTION SPRING	1		
3-006	837-06092-200	FRICTION PLATE	1		
3-007	832-01250-200	RETURN SPRING	1		
3-008	990-15050-121	SCREW 5X12	1		
3-009	783-06092-200	ROPE 3.5X890L	1		
3-010	785-06097-200	STARTER HANDLE	1		
3-011	780-06150-200	ROPE GUIDE	1		
3-012	795-0602K-200	STARTER HANDLE CAP	1		

FIG.4 AIR CLEANER

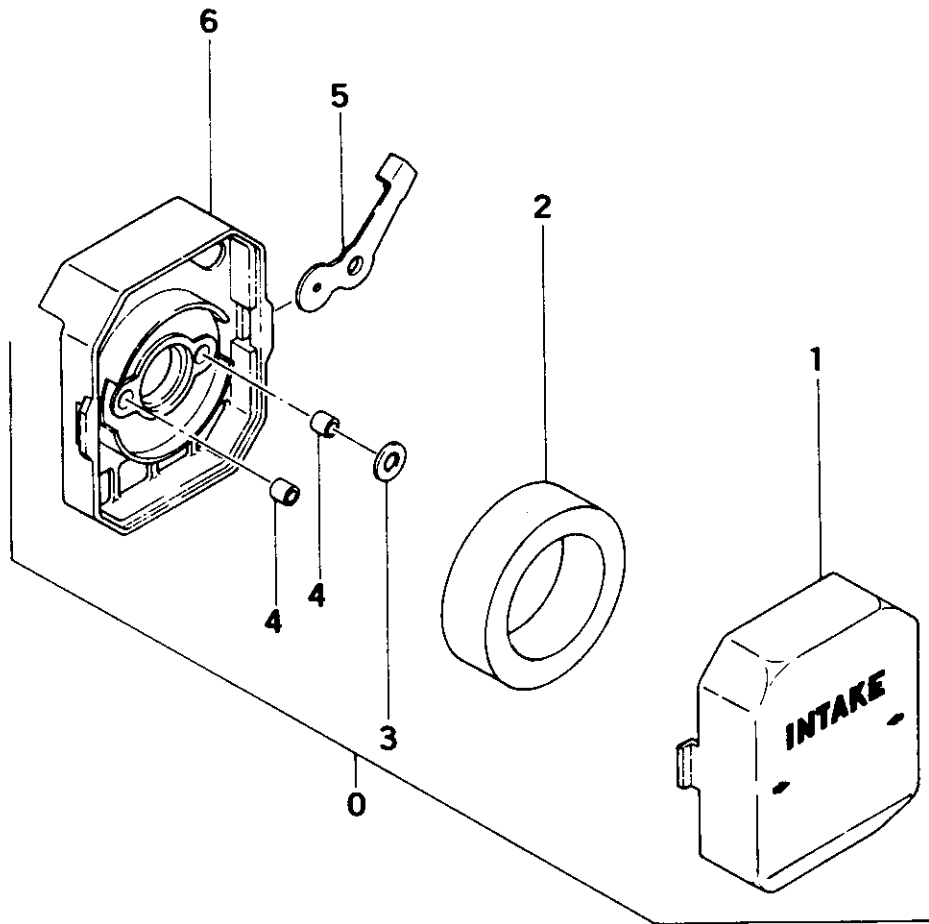

REF. NBR	PART NBR	PART NAME	QTY	SERIAL NBR	REMARKS
4-000	410-0602D-901	AIR CLEANER ASS'Y	1		
4-001	424-0602K-201	AIR CLEANER CAP	1		
4-002	446-0602K-200	CLEANER ELEMENT	1		
4-003	453-0602K-200	SPACER	1		
4-004	470-0602K-200	COLLAR	2		
4-005	528-0602D-200	CHOKE PLATE,V/2MM HOLE	1		
4-006	423-0602K-210	CLEANER BODY	1		

FIG.5 CARBURETOR

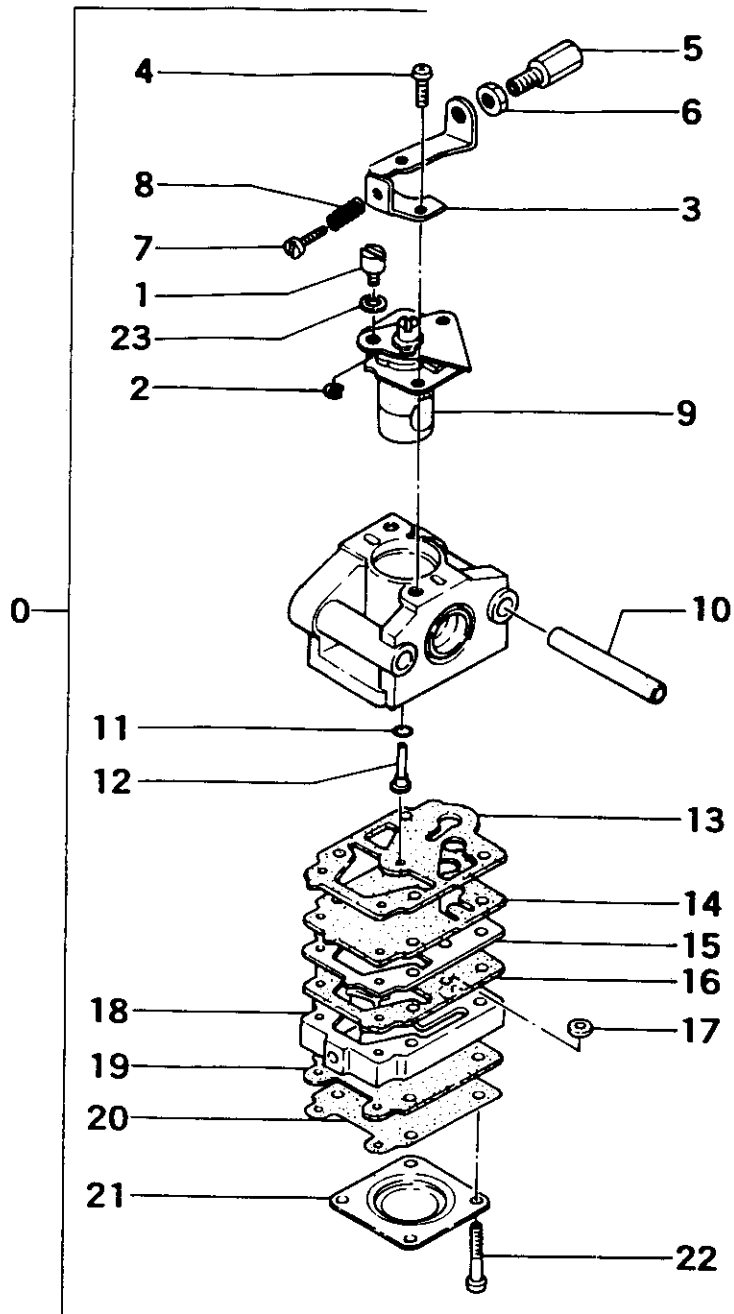

REF. NBR	PART NBR	PART NAME	QTY	SERIAL NBR	REMARKS
5-000	455-25102-901	CARBURETOR ASS'Y WY-8A	1	-G234770	
5-000	455-25102-902	CARBURETOR ASS'Y WY-8B	1	P -H020391	
5-000	455-25102-902	CARBURETOR ASS'Y WY-8B	1	R -H020391	
5-000	455-25102-903	CARBURETOR ASS'Y WY-8C	1	H020392-	
5-001	539-25101-200	SWIVEL	1	M	
5-001	539-25100-200	SWIVEL	1		
5-002	489-25100-200	STOP RING	1		
5-003	544-25100-200	ADJUSTER STAY	1		
5-004	514-25100-200	THROTTLE SET SCREW	2		
5-005	614-25100-200	CABLE ADJUSTER	1		
5-006	613-25100-200	CABLE ADJUST NUT	1		
5-007	462-25100-201	IDLE ADJUST SCREW	1		
5-008	463-25100-200	IDLE ADJUST SPRING	1		
5-009	488-25100-800	THROTTLE VALVE COMP.	1	-G234770	
5-009	488-25106-800	THROTTLE VALVE COMP.	1	M G234771-	
5-010	437-25100-200	SLEEVE	2		
5-011	550-25100-200	O-RING	1		
5-012	599-2000W-520	MAIN JET #52	1	-G234770	
5-012	599-2000W-460	MAIN JET #46	1	M -H020391	
5-012	599-2000W-460	MAIN JET #46	1	R -H020391	
5-012	599-25100-248	MAIN JET #48	1	M	
5-012	599-2000W-480	MAIN JET #48	1	H020392-	
5-013	577-25100-200	PUMP GASKET	1		
5-014	576-25100-200	PUMP DIAPHRAGM	1		
5-015	523-25100-201	PUMP PLATE	1		
5-016	522-25100-200	CIRCUIT PLATE	1		
5-017	578-25001-200	INLET SCREEN	1	R -G234770	
5-017	578-25007-200	INLET SCREEN	1	G234771-	
5-018	575-25100-800	PUMP BODY COMP.	1		
5-019	475-25001-200	DIAPHRAGM GASKET	1		
5-020	474-25001-800	METERING DIAPHRAGM COMP.	1		
5-021	476-25004-200	DIAPHRAGM COVER	1	M	
5-021	476-25006-200	DIAPHRAGM COVER	1		
5-022	548-25101-200	SET SCREW	4	M	
5-022	548-25100-200	SET SCREW	4		
5-023	549-25100-200	THRUST WASHER	1		

FIG.6 GEAR CASE & CUTTER

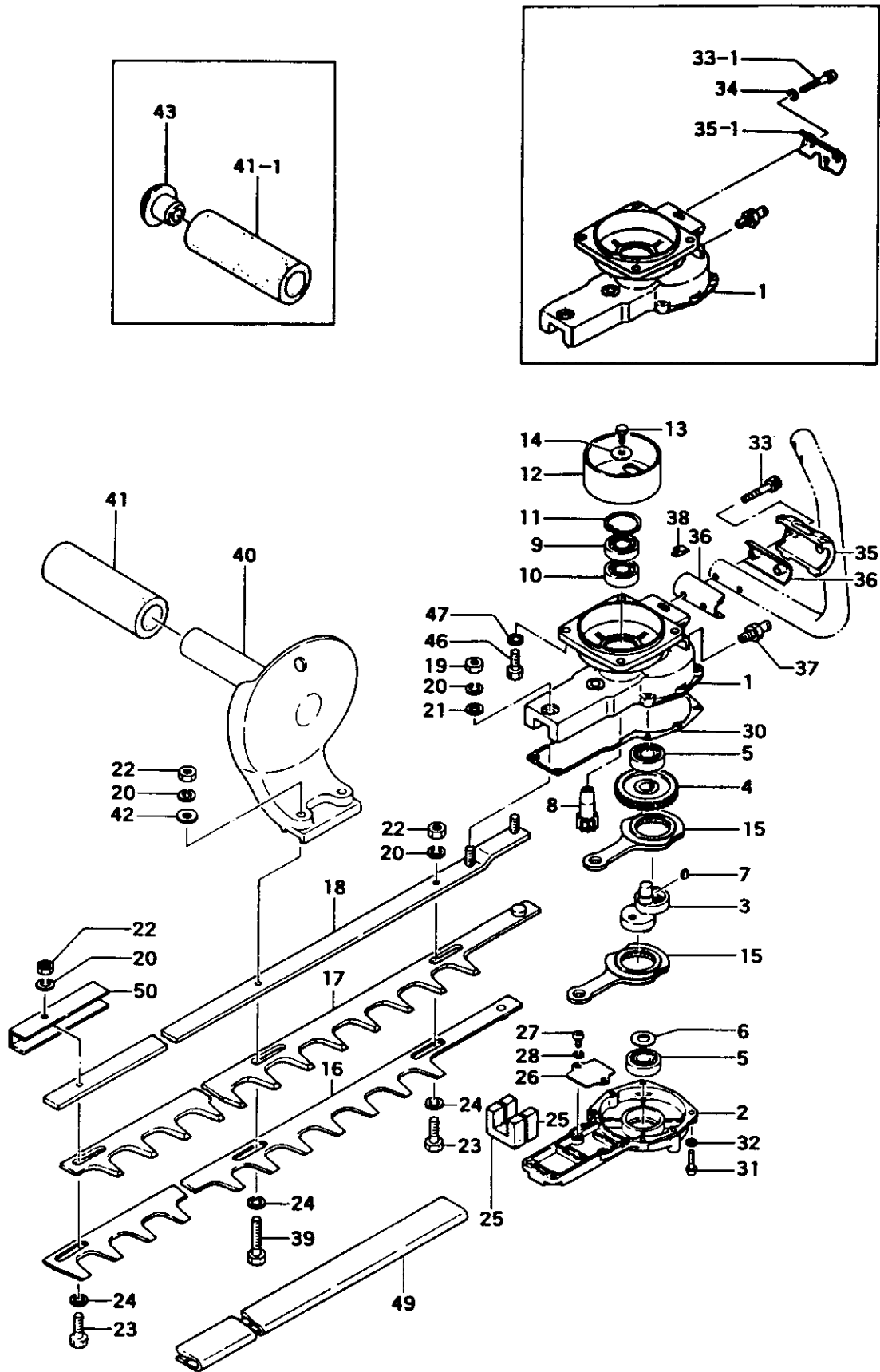

REF. NBR	PART NBR	PART NAME	QTY	SERIAL NBR	REMARKS
6-001	300-33230-210	GEAR CASE A	1	-G234770	
6-001	300-33230-220	GEAR CASE A	1	G234771-	
6-002	301-33230-200	GEAR CASE B	1		
6-003	100-33210-203	CAM SHAFT	1		
6-004	307-33230-200	GEAR 2	1		
6-005	999-61629-000	BALL BEARING #629, 26MM/OD	2		
6-006	015-35100-200	SHAFT SHIM 0.1 (9.3X18)	V		
6-006	016-35100-201	SHAFT SHIM 0.2 (9.3X18)	V		
6-006	022-35100-200	SHAFT SHIM 0.3 (9.3X18)	V		
6-007	068-00300-200	WOOD-RUFF KEY 3X10X3.7	1		
6-008	306-33230-210	GEAR 1	1		
6-009	999-61600-003	BALL BEARING 6000D, 26MM/OD	1		
6-010	999-61600-000	BALL BEARING #6000, 26MM/OD	1		
6-011	993-51026-002	STOP RING C-26 IM	1		
6-012	288-0602W-821	CLUTCH DRUM COMP.	1		
6-013	990-21050-106	H.T. BOLT 5X10	1		
6-014	368-32350-200	BRAKE SHAFT WASHER	1		
6-015	101-33230-800	CAM ROD COMP.	2		
6-016	120-33202-203	CUTTER A, L-825	1		
6-017	121-33202-203	CUTTER B, L-825	1		
6-018	122-33202-203	CUTTER GUIDE, L-832.5	1		
6-019	991-01060-011	NUT 6	2		
6-020	992-10060-012	S. WASHER 6	7		
6-021	992-01060-011	WASHER 6	2		
6-022	123-33202-200	CUTTER FIXING NUT	5		
6-023	124-33202-206	CUTTER FIXING BOLT A	4		
6-024	129-33202-201	WASHER 7	5		
6-025	085-33230-200	GREASE SEAL A	2		
6-026	075-33230-200	CAM ROD GUIDE PLATE	1		
6-027	990-11040-081	SCREW 4X8	2		
6-028	992-10040-012	S. WASHER 4	2		
6-030	303-33230-200	GEAR CASE GASKET	1		
6-031	990-11040-161	SCREW 4X16	6		
6-032	992-10040-012	S. WASHER 4	6		
6-033, 1	990-11050-271	SCREW 5X27	2	-G234770	
6-033	990-51050-353	HEX. HOLE BOLT 5X35	2	N G234771-	
6-034	992-10050-012	S. WASHER 5	2	D G234771-	
6-035, 1	057-33260-200	HANDLE HOLDER	1	-G234770	
6-035	057-33250-200	HANDLE HOLDER	1	N G234771-	
6-036	060-33250-200	DAMPER RUBBER	2	N G234771-	
6-036	060-33250-200	DAMPER RUBBER	2	-H161320	
6-036	060-33250-201	DAMPER RUBBER	2	P H161321-	
6-037	200-33210-210	GREASE NIPPLE	1		
6-038	176-33410-200	EARTH TERMINAL	1	N G234771-	
6-039	125-33202-205	CUTTER FIXING BOLT B	1		
6-040	051-33210-820	HANDLE B COMP.	1		
6-041, 1	165-33250-200	HANDLE GRIP	1	-H242200	
6-041	503-37500-200	HANDLE GRIP	1	P H242201-	
6-042	992-01060-011	WASHER 6	1		
6-043	212-33250-200	GROMMET	1	D H242201-	
6-046	990-23060-161	PLUS BOLT 6X16	4		
6-047	992-10060-012	S. WASHER 6	4		
6-049	138-33215-202	CUTTER COVER, L-773	1		
6-050	128-33202-200	BLADE HOLDER	1	N G234771-	

FIG.7 HANDLE

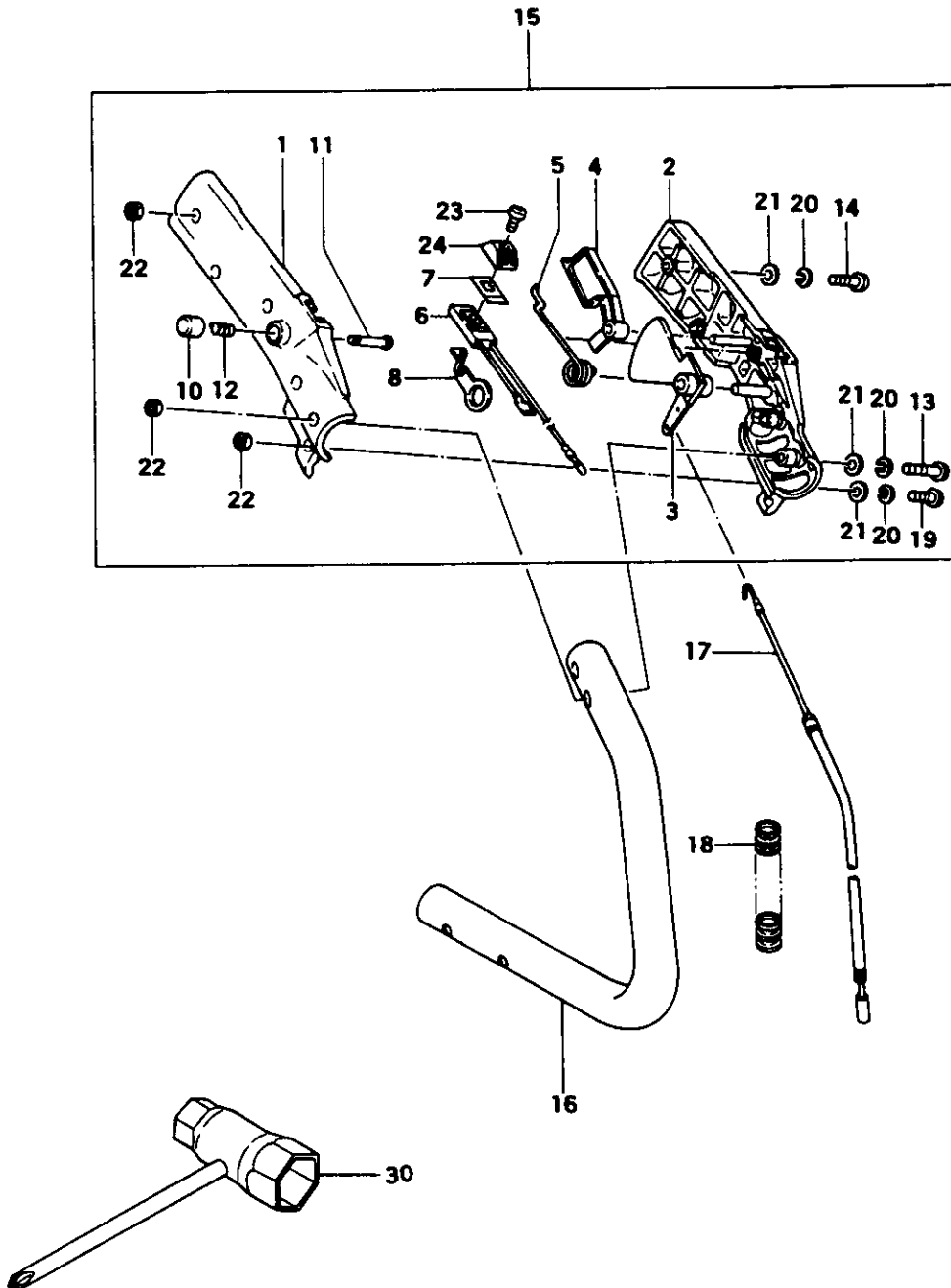

REF. NBR	PART NBR	PART NAME	QTY	SERIAL NBR	REMARKS
7-001	053-33231-220	HANDLE GRIP A	1		
7-002	054-33231-220	HANDLE GRIP B	1		
7-003	230-33210-201	THROTTLE LEVER	1		
7-004	231-33210-200	SAFETY LEVER	1		
7-005	061-32800-201	THROTTLE LEVER SPRING	1		
7-006	170-33250-800	STOP SWITCH COMP.	1		
7-007	925-32530-200	STOP BUTTON MARK	1		
7-008	319-37900-200	EARTH TERMINAL	1		
7-010	725-32600-202	PUSH PIN CAP	1		
7-011	064-32530-200	PUSH PIN	1		
7-012	066-32300-201	STOPPER SPRING	1		
7-013	990-11040-301	SCREW 4X30	2		
7-014	990-11040-251	SCREW 4X25	1		
7-015	055-33250-903	HANDLE GRIP ASS'Y	1		
7-016	050-33250-201	HANDLE A	1	-G234770	
7-016	050-33250-210	HANDLE A	1	N G234771-	
7-017	885-0639T-800	THROTTLE WIRE COMP.	1	-H161320	
7-017	885-0639T-801	THROTTLE WIRE COMP.	1	P H161321-	
7-018	164-10010-000	PROTECTION TUBE 10X100L	1		
7-019	990-11040-141	SCREW 4X14	3		
7-020	992-10040-012	S.WASHER 4	6		
7-021	992-00040-011	SMALL WASHER 4	6		
7-022	991-74040-010	U-NUT 4	6		
7-023	994-31030-101	SCREW 3X10	1		
7-024	258-11600-200	BUTTON STOP	1		
7-030	036-29331-501	COMBI. BOX SPANNER 10X19 .PLUS	1		

FIG.8 MARKS

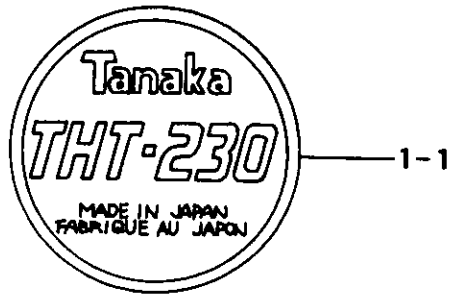

REF. NBR	PART NBR	PART NAME	QTY	SERIAL NBR	REMARKS
8-001, 1	906-0639A-200	NAME PLATE	1	-H242200	
8-001	950-37900-200	PROFORCE MARK A	1	N H242201-	
8-002	906-33260-200	NAME PLATE	1	N H242201-	
8-003	951-37900-200	PROFORCE MARK B	1	N H242201-	

Free Manuals Download Website

<http://myh66.com>

<http://usermanuals.us>

<http://www.somanuals.com>

<http://www.4manuals.cc>

<http://www.manual-lib.com>

<http://www.404manual.com>

<http://www.luxmanual.com>

<http://aubethermostatmanual.com>

Golf course search by state

<http://golfingnear.com>

Email search by domain

<http://emailbydomain.com>

Auto manuals search

<http://auto.somanuals.com>

TV manuals search

<http://tv.somanuals.com>