

129HS

*Instruction manual*

*Blade hedge  
trimmer*

***Important!***

Read this instruction manual carefully  
before first operation and strictly observe  
the safety regulations!



## Preface

Dear Customer,

Congratulations for choosing this SOLO quality product.

The SOLO blade hedge trimmer 129HS is a particularly ergonomically designed power tool with a modern, high-performance engine. This trimmer offers you a professional, easy to maintain layout.

The proven technology used in the Nikasil-coated vertical cylinder 2-cycle engine guarantees high performance and low fuel consumption.

The Primer-start system and the comfortable "easy-start" system ensure particularly good starting characteristics.

The shaft has been insulated against vibration using a special system and the multifunctional handle with throttle safety catch, half throttle catch and stop switch ensure operator comfort and fatigue-free operation with this power tool.

Prior to operating the unit, please read the owner's manual carefully, and most importantly, observe all safety rules.

Observe the maintenance guidelines closely to ensure the long service life of your equipment.

Your dealer will be glad to assist you with any questions.

### Packaging

The packing materials used to protect the unit against damage during transportation are cartons made from pulp, which can be re-used or recycled.

## Symbols

The following symbols are used in this manual and on the product:



Always handle this power tool with particular care



Thoroughly read these operating instructions before undertaking any maintenance, installation and cleaning steps



Wear ear defenders and a face shield before starting the engine. We recommend you wear a protective helmet



Wear solid shoes, preferably safety shoes with a good tread



Wear protective gloves when handling and working with the equipment



Never touch the cutting blades



Maintain a minimum distance of 5 metres by bystanders



Never smoke near the power tool or where the equipment is refuelled!



Keep open flames away from the power tool and the fuel can



- This equipment produces exhaust fumes and  
- fuel vapours are poisonous;  
never start or refuel in enclosed spaces

### CE Declaration of conformity

In accordance with EG Directives 98/37/EC, 2000/14/EC and 89/336/EEC (amended by 92/31/EEC), SOLO Kleinmotoren GmbH, Stuttgarter Strasse 41, D-71069 Sindelfingen, being solely responsible, states that the product referred to in this declaration complies with the requirements of the Machinery Directive.

Product designation:: Blade hedge trimmer

Model/type: **129HS**

Sound power level (DIN45635)

Guaranteed sound 110 dB(A)

Actual sound 106 dB(A)

Applied standards: EN 774

Conformity assessment procedures Appendix V

This declaration of conformity loses its validity, if the equipment is converted or modified without the manufacturer's consent.

Sindelfingen,  
1- January 2006  
SOLO Kleinmotoren GmbH

Wolfgang Emmerich  
Executive Director

	Page
<b>1. Safety regulations</b> .....	<b>4</b>
1.1 <i>General safety instructions</i>	4
1.2 <i>Working clothes</i>	4
1.3 <i>Fuelling</i>	5
1.4 <i>When transporting the equipment</i>	5
1.5 <i>Maintenance and repairs</i>	5
1.6 <i>Preparing the equipment for starting</i>	5
1.7 <i>Starting</i>	5
1.8 <i>Working with the machine</i>	6
<b>2. Standard delivery</b> .....	<b>7</b>
<b>3. Control and function elements</b> .....	<b>7</b>
<b>4. Fuelling</b> .....	<b>8</b>
4.1 <i>Fuel information</i>	8
4.2 <i>Mixing ratio</i>	8
4.3 <i>Fuelling</i>	8
<b>5. Starting / Stopping the engine</b> .....	<b>8</b>
5.1 <i>Half throttle start position</i>	8
5.2 <i>Choke and primer</i>	8
5.3 <i>Starting</i>	9
5.4 <i>Engine will not start:</i>	9
5.5 <i>Turning off the engine:</i>	9
<b>6. Adjusting the handle and mitre gear</b> .....	<b>10</b>
<b>7. Using your blade hedge trimmer</b> .....	<b>10</b>
7.1 <i>Scope of Application</i>	10
7.2 <i>Correct operation of your blade hedge trimmer</i>	10
7.3 <i>Decorative cutting</i>	11
<b>8. Operating and maintenance instructions</b> .....	<b>12</b>
8.1 <i>Blade</i>	12
8.2 <i>Gear lubrication</i>	12
8.3 <i>Air Filter Maintenance</i>	12
8.4 <i>Carburettor adjustment</i>	13
8.5 <i>Information about the spark plug</i>	13
8.6 <i>Information about the silencer</i>	14
8.7 <i>Replacing the fuel filter</i>	14
8.8 <i>Shutdown and storage</i>	14
8.9 <i>Scheduled maintenance</i>	15
<b>9. Specification</b> .....	<b>16</b>
<b>10. Accessories</b> .....	<b>17</b>
<b>11. Parts subject to wear and tear</b> .....	<b>17</b>
<b>12. Guarantee</b> .....	<b>17</b>

## 1. Safety regulations

### 1.1 General safety instructions



Read the operating instructions carefully before placing in service and keep them in a safe place.



Use this power tool with particular caution.

Non-observance of safety instructions can lead to a risk to life. Also observe any regulations from your professional body. These operating instructions must always be available at the place of work. All individuals instructed to work with the equipment (including maintenance, care and repair), should read these instructions.

- When operating in highly flammable vegetation and in areas affected by drought, keep a fire extinguisher handy (risk of fire).
- You should request and receive instructions from the vendor on the safe operation if you are using this type of product for the first time.
- This machine may only be used within the prescribed scope of application as stated in section 7.1 "Scope of Application".
- Children and young people under 18 years may not work with this power tool, with the exception of young people over 16 years of age who are being trained under supervision.
- The power tool can be operated easily - even on start-up - by one person. Keep bystanders and animals away from the working area. Maintain a minimum distance of 5 m. When working near thickets, be aware that children and animals may be hidden there. Immediately stop the machine and the cutter if any person or animal comes close to the working area. The operator is responsible for any accidents or damage caused to parties or property.
- This machine may only be passed on or lent to third parties if they are familiar with the safe use of this product and with these instructions. Always supply the manual with the machine.
- Ensure you are rested and in good health when using this machine.
- Persons under the influence of alcohol or drugs, including prescription drugs, are not allowed to use this machine, as their ability to quickly react to potential danger may be impaired.
- Never alter, change or modify any safety equipment or functional assemblies on this machine.
- Only use this machine if it is in good, safe condition. Always check the machine prior to use. **Risk of accident!**
- Only use those accessories and attachments that have been supplied by the manufacturer and that are expressly approved for attachment.
- The reliability and safe operation of your machine depend on the quality of parts used with the machine. Only use original spare parts. Original spare parts are identical with genuine production parts and guarantee best quality in material, dimensions, function and safety. Original parts and accessories are available from your specialist dealer. Your dealer has been supplied with appropriate documentation to determine the correct parts. Your dealer is frequently supplied with updates about improvements to the equipment. Please note that the use of non-original parts will void your warranty.
- Always store the machine in a safe place and in such a way that it will not pose any danger. Stop the engine when the machine is not used.

Persons who disregard safety instructions, operating or maintenance instructions may be liable for any damage or consequential losses.

### 1.2 Working clothes

To prevent injuries, always wear suitable clothing and safety equipment when working with this power tool. This clothing should be practically oriented to the application (for example a tight fitting work suit), but should not be confining.

We recommend: **SOLO forest and countryside work jacket EN 340** Part no: 99 303 000 + size (2[s] - 6[xxl])  
**SOLO Outdoor Knee-breeches** Part no: 99 020 95 + size  
 or **SOLO Outdoor dungarees** Part no: 99 020 94 + size

Never wear scarves, ties, jewellery or other items of clothing, which might get caught in the equipment, in brush or on branches. Safely tie back long hair (use a cap, helmet or similar)..



Wear sturdy shoes with a good tread - ideally safety shoes.

We recommend: **SOLO leather forest boots** Part no: 99 305 00 + size (36 - 48).



Wear protective gloves with non-slip palms.

We recommend: **SOLO Fit** Part no: 99 390 1200 (one size).



Use ear defenders and/or a visor for protection against flying objects or objects caught up in the turbulence (protective goggles for example). Wear a protective helmet to protect against injury due to falling cuttings.

We recommend: **SOLO protective helmet with face and ear protection** Part no: 99 390 1100 (one size).

### 1.3 Fuelling



Petrol is very light and highly flammable. Keep away from open flames and never spill fuel. Do not smoke at the operating site or at and near the refuelling site!

- Stop the engine prior to refuelling.
- Let the engine cool down before refuelling - fire risk!
- Open the tank lid slowly to allow any excess pressure in the tank to be reduced without the risk of petrol spraying out.
- Fuel may contain substances similar to solvents. Prevent products made from mineral oil coming into contact with skin and eyes. Wear protective gloves during filling with fuel. Frequently change and clean protective clothing.
- Avoid breathing in fuel vapour.
- The refuelling site should be well ventilated.
- Avoid any soil spillage of fuel or oil (protection of the environment). Use a suitable mat.
- Immediately clean any spilled fuel on the machine. Change contaminated clothing without delay.
- Firmly tighten all tank lids. This will reduce the risk of spillage from lids, which have become loose from engine vibrations.
- Check for petrol leaks. Do not start the machine or work with the machine if there is a petrol leak. Life threatening risk from burns!
- Store fuel and oil in approved and correctly labelled containers.

### 1.4 When transporting the equipment

- Always turn off the engine when transporting the machine.
- Never carry or transport this machine with the engine running.
- Always ensure that the blade is secured before transporting the tool over longer distances.
- To prevent fuel running out and associated damages, secure the equipment against tipping over during vehicle transportation. Check the tank for leaks. It is advisable to drain the tank before transportation.
- Drain the tank before despatching the equipment.

### 1.5 Maintenance and repairs

Regularly service this machine. Only carry out those maintenance jobs and repairs, which are described in this manual. A specialised service centre will carry out all other jobs.

- Do not maintain, repair or store the machine near an open flame.
- Before cleaning, maintenance and repair work, always stop the engine first and pull the spark plug cap. Exceptions: carburettor and idle adjustments.
- For any repairs only use original parts from the manufacturer.
- Do not modify, alter or change the machine as this may impact on the safe operation of the machine and may lead to accidents and injuries!

### 1.6 Preparing the equipment for starting

Check the complete machine for operational safety. In **addition** to the information in the operating and maintenance instructions (chapter 8), implement the following checks:



- The stop switch should function properly.
- The throttle must have freedom of movement and return to the idle position on its own accord.
- The cutter and both handles must be tightly secured and in perfect working order.
- Ensure the spark plug cap and the ignition cable are connected firmly. A loose connection may cause a spark, which can ignite any existing fuel:air mixture - fire hazard!

Should the check reveal any irregularities or recognisable damage (also to the frame), incorrect adjustments or reduced efficiency of the machine, do not commence work. Take the power tool to a specialised workshop and have it checked.

### 1.7 Starting

- Start the machine no less than 3 metres from the refuelling location. Never start the machine in an enclosed space.
- Ensure that you are standing firmly on the ground when starting. Always start on even ground, with a firm grip on the power tool.
- Continue with the starting procedure as described in section 5. "Starting/Stopping the engine".
- Check the idle speed setting after starting. The cutter must not move at idle speed.

## 1.8 Working with the machine

- **Environmental protection:**
  - Avoid excessive noise and exhaust fumes when operating this power tool, and never run the engine unnecessarily. Ensure compliance with any local noise regulations.
  - Ensure compliance with any local regulations concerning the cutting of hedges or periods where such work is prohibited.
  - Before commencing such work, ensure that no birds are nesting in your hedges. If you do discover nesting birds, postpone the work or avoid this area when trimming your hedges.
  - To avoid harming any other animals you may find in your hedges, check under all hedges before trimming and scare any animals away.
  - Dispose of any cuttings in an environmentally responsible manner (for example, by composting).
- Only use this power tool when it is complete and in a safe condition.
  -  As soon as the engine is running, the power tool generates toxic gases, which may be invisible and odourless. Never work with the power tool in enclosed spaces. In confined conditions such as pits or excavations, ensure adequate air changes during work.
  -  Do not smoke at the work site and in the immediate vicinity of the power tool. There is an increased fire hazard!
- Work conscientiously, thoughtfully and calmly, and do not endanger third parties.
  - Pay attention to good visibility and lighting conditions.
  - Never work near a HV line or other 'live' cables.
  - Always remain within earshot of other people who can provide help in case of emergency.
  - Plan for timely work breaks.
  - Pay attention to possible hazards and take appropriate precautions. Be aware that wearing ear defenders reduces the ability to perceive noise. This includes sounds alerting to danger such as signals, shouts, etc. that can go unnoticed.
  - Exercise caution when the ground is wet or covered in ice and snow, on overhangs, or uneven terrain. There is an increased risk of slipping!
  - Pay attention to the risk of stumbling and obstacles, such as tree roots and stumps, edges, etc. Pay particular attention to safety when working on slopes.
  - Before commencing work, check the working area for stones, broken glass, nails, wire or other solid objects and remove such debris to prevent them being picked up and thrown out by the cutters.
  - Always hold this power tool firmly in both hands, and ensure your safe and solid foothold.
  - Keep all body parts away from the blades. Always cut away from your body.
  - Always cut in an efficient and correct manner (see chapter 7.2 "Correct operation of your blade hedge trimmer").
  - Never touch the ground with your running hedge trimmer.
  - Never use the hedge trimmer to lift away or move pieces of wood or similar materials.
  - Only use the device with sharp and undamaged blades and avoid damaging the blade on foreign objects.
- Switch the engine off if the device behaves in any way unusually.
- Due to the centrifugal clutch, the cutters will run on for a short time, even if you release the throttle. Ensure the cutter has come to a full stop before storing the machine.
- Always stop the engine before any contact with the cutter – even when clearing a blockage or if cutters have become jammed – wait until the cutter has stopped and remove the spark plug cap.
- Never touch the exhaust or the silencer; as long as they are still hot, there is a risk of burns!
- Never work with a defective or missing silencer. There is a hazard of hearing damage and burning!

### **First Aid**

A first aid box should always be available on-site. Immediately replace any materials you have used:

Note:

Over exposing persons with circulatory problems to vibrations can lead to damage to their nervous system or blood vessels. The following systems may occur from vibrations to fingers, hands or the wrists: Numbness, itching, pain, twinges, changes to the colour of the skin or the skin itself. Seek medical advice if you experience any of these symptoms.

## 2. Standard delivery

- **Blade hedge trimmer**
- **Cutting blade protector**
- **Shoulder strap**
- **Tools:** combination spanner and screw driver

- **Instruction manual**

## 3. Control and function elements

### Cutting blade and gear:

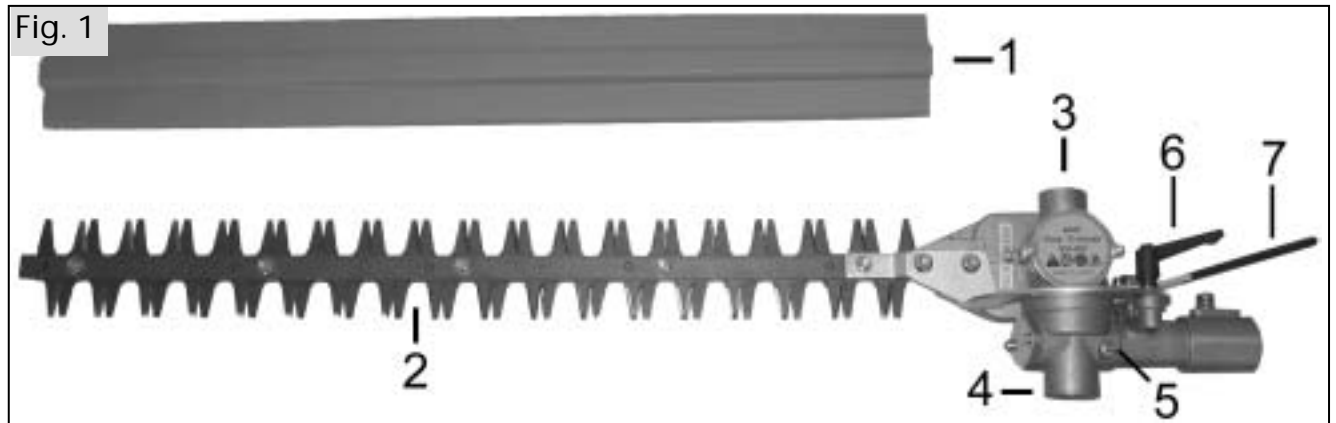

- Fig. 1:
- 1 Cutting blade sheath
  - 2 Cutting blades
  - 3 Cutter gearbox
  - 4 Angular gear
  - 5 Angular gear grease nipple
  - 6 Cutting edge angle straining screw
  - 7 Pivoting lever

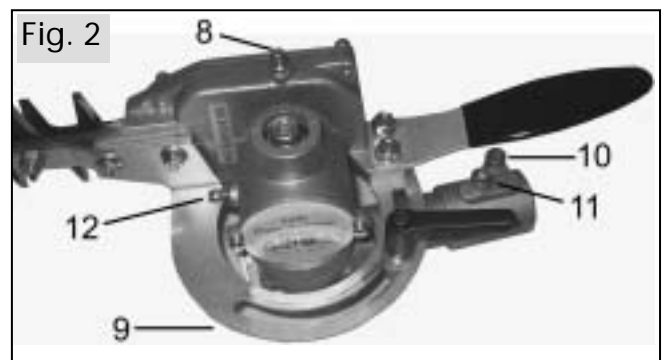

- Fig. 2:
- 8 Cutter gearbox grease nipple
  - 9 Cutting edge angle guide
  - 10 Shaft tube straining screw
  - 11 Fixing screw
  - 12 Clutch mid-section grease nipple

### Engine and handle

- Fig. 3:
- 13 Stop-switch
  - 14 Throttle lever
  - 15 Throttle lock
  - 16 Half throttle lock
  - 17 Loop handle
  - 18 Choke lever
  - 19 Primer
  - 20 Fuel cap
  - 21 Starter grip
  - 22 Air filter cover
  - 23 Harness rail
  - 24 Anti-vibration system
  - 25 Quick acting tension screw
  - 26 Sparkplug cap

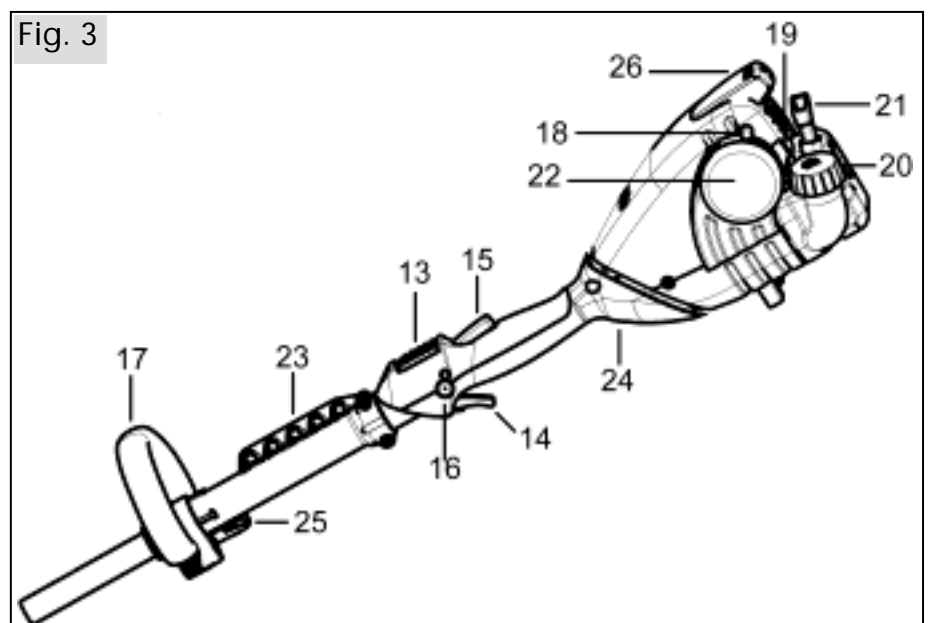

## 4. Fuelling

### 4.1 Fuel information

A high performance two-stroke engine operated with a petrol:oil mixture (petrol + oil = fuel mixture) or with a special fuel mixture for two-stroke engines available from specialists powers this machine. The fuel mixture can be made up with standard lead-free petrol or with lead-free premium grade petrol. The minimum octane rating for petrol is 92 ROZ.

Unsuitable petrol or deviations in the mixing ratio may lead to serious engine damage!

 Avoid direct skin contact with petrol and avoid inhaling petrol fumes - health hazard!

### 4.2 Mixing ratio

Always use a fuel:oil ratio of 25:1 (4%) for the first five tank fillings.

After that we recommend a ratio of 50:1 (2%) with the use of special two-stroke oil "SOLO 2T engine oil" which we can supply.

With the use of other brand two-stroke oils we recommend a ratio of 25:1 (4%).

Never store fuel mixture longer than 3 - 4 weeks.

#### Fuel mixture table

Petrol in litres	Oil in litres	
	SOLO 2T engine oil 2% (50 : 1)	Other two-stroke oils 4% (25 : 1)
1	0,020	0,040
5	0,100	0,200
10	0,200	0,400

### 4.3 Fuelling

While fuelling always follow all safety instructions and take all safety precautions.

Handle fuel only with the engine turned off. Carefully clean the area around the filler inlet. Place the machine with the fuel inlet pointing upwards. Unscrew the tank lid and fill the fuel mixture up to the lower edge of the filler neck. Use a funnel with filter to prevent tank contamination. After filling the tank replace the tank lid and tighten firmly.

## 5. Starting / Stopping the engine

### 5.1 Half throttle start position

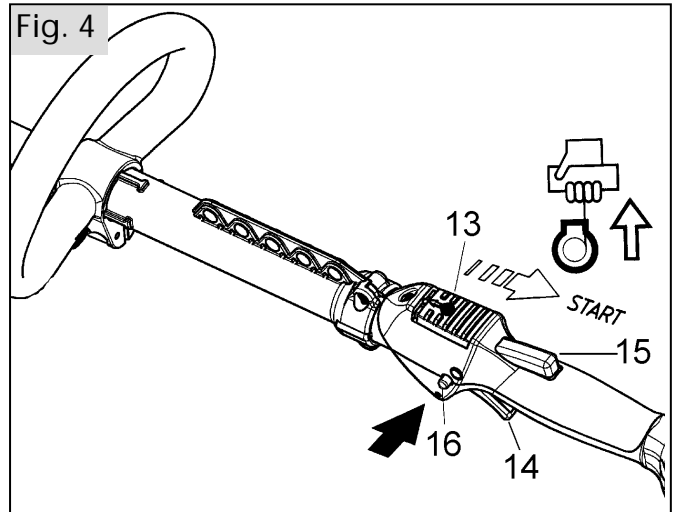

- Move the stop switch (13) to "Start".
- Grip the handle; the safety locking key (15) is activated via the grip area, which also enables throttle lever (14) to be regulated.
- Press throttle lever (14) fully down.
- Press the half throttle lock (16), and let the throttle lever return, whilst holding the half throttle lock in.

### 5.2 Choke and primer

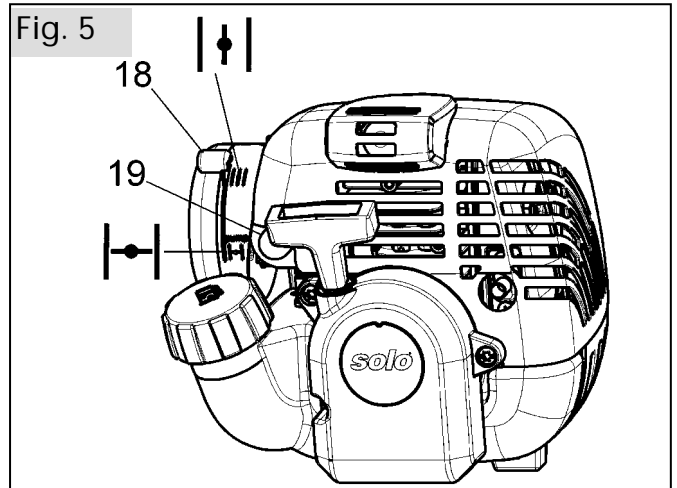

Adjust choke (18) as follows:

- With a cold engine, position choke lever (18) down towards "Close" ↓.
- With a warm engine, position choke lever (18) up towards "Open" ↑.

When first starting or if the fuel tank has been completely drained and has been refilled, press primer (19) several times (at least 5x) until the fuel is visible in the plastic bulb..



### 5.3 Starting

Observe the safety instructions when starting.

**Note:** Your new brushcutter is, as standard, fitted with the **"Easy-Start-System"**. This enables the engine to be started without major effort. By pulling on the starter cord – perhaps several times – a spring box is loaded inside the starter. For this, you do not need to pull quickly. The engine will start automatically, as soon as sufficient tension has accumulated. This may also happen when the starter cord returns to its rest position.

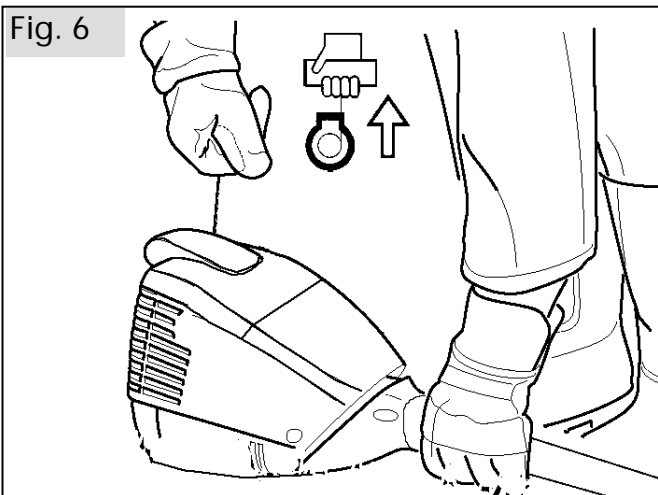

Place the power tool flat on a clear, flat surface and ensure that the blade is not touching any other object. If necessary, position something under the shaft a little in front of the mitre gear.

During starting, never stand or kneel on the shaft tube, otherwise the shaft or the tube might be damaged.

Take up a safe position, securely hold the machine and ensure that the cutter does not touch any objects or the ground.

If the engine is cold:

With the choke lever down (↓), pull the starter cord several times in a straight line, until you can hear the engine firing.

Immediately afterwards, move the choke lever up (↑). Continue starting until the engine turns over.

If the engine is warm:

With the choke lever up (↑), start until the engine turns over.

The following instructions are aimed at increasing the service life of the starter rope and of the starter mechanism:

- Pull the starter cord out, until you can feel a definite resistance; then pull it through quickly and firmly.
- Always pull the rope out in a straight line, do not let the rope drag across the edge of the rope eyelet.
- Do not pull rope all the way out - risk of the rope breaking.

- Always manually guide the rope back into its start position with your hand on the starter grip - do not let it retract on its own.

A specialist can replace a damaged starter rope.

Once the engine runs, briefly pull the throttle back to release the half throttle detent. Release the throttle lever again to allow the engine to run at idle speed. Now you can commence working.

### 5.4 Engine will not start:

If the engine fails to start after several attempts, check whether all adjustments described above have been correctly carried out, particularly that the stop switch is **not** in the "STOP" position. Try starting once again. The combustion chamber will be flooded, if the engine still fails to start.

In that case we recommend you proceed as follows:

- Remove the spark plug cover.
- Pull the spark plug cap off the spark plug.
- Remove the spark plug and dry fuel mixture from the electrodes.
- Move the throttle lever up to full throttle. Pull the starter handle several times (with removed spark plug) to clear the combustion chamber.
- Move the throttle lever down to idling position, refit the spark plug, the plug cap and the plug cover.
- Start the engine with the choke lever up (↑) and the stop switch in the "Start" position.

### 5.5 Turning off the engine:

Release the throttle and push the stop switch to "STOP".

**Important:** Due to the centrifugal clutch, the cutter will run on for a short time, even if you release the throttle. Ensure the cutter has come to a full standstill before storing the machine.

**Emergency stop** Should the engine – due to a faulty stop switch – fail to stop, it can also be stopped by closing the choke (choke lever in position ↓). **After such an event, do not restart the engine, but have the equipment checked by an authorised service shop.**

## 6. Adjusting the handle and mitre gear

Always turn off the engine before any installation or adjustment; place the stop switch in position "Stop" and if necessary wait until the blade has stopped.

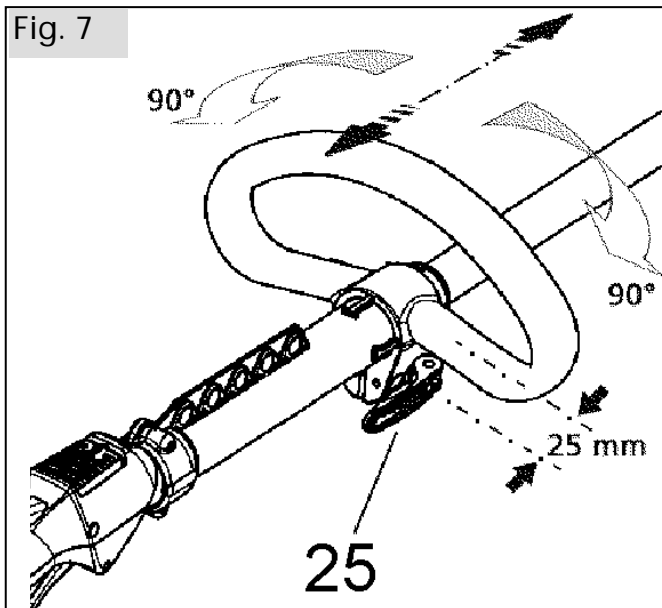

The loop handle can be adjusted forward by approx. 25mm, if required for balance. For special applications, such as for trimming edges, the loop handle can be moved 90 degrees.

To lock the loop handle in place, simply tighten knurled nut by hand and secure with lock lever (25).

**Please note:** Before commencing work, check that the loop handle has been safely secured using the quick acting lock.

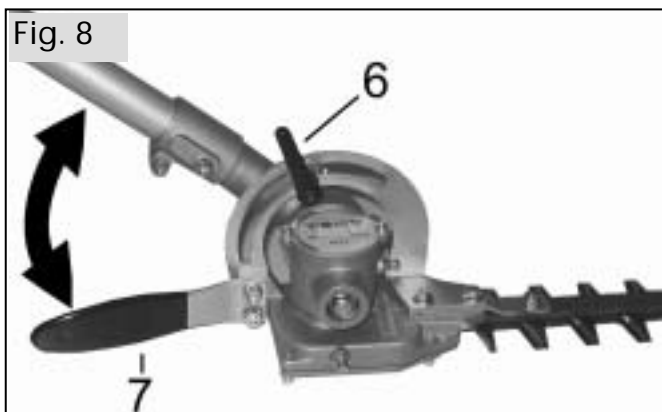

The desired cutting blade angle can be attained by releasing the cutting edge angle straining screw (6). Always set the desired angle via the pivoting lever (7). Never touch the blades when setting the cutting blade angle. Tighten the cutting edge angle straining screw (6).

Total adjustable angle 135°, upward (in direction of the loop handle) max. 90°, downward max. 45°

## 7. Using your blade hedge trimmer

### 7.1 Scope of Application

The blade hedge trimmer must only be used to trim hedges, shrubs and bushes.

Never use the hedge trimmer for any other purpose.

The maximum thickness of twigs and branches, which can be cut by this hedge trimmer, depends on the type of wood, its age, its moisture content and density.

Thicker twigs and branches can be trimmed to the required length with pruning shears before cutting with the hedge trimmer.

### 7.2 Correct operation of your blade hedge trimmer

Observe all safety regulations when using this power tool.



Always hold the blade hedge trimmer carefully with both hands and firmly grip the handle with your thumbs. Utilise the shoulder strap. Hold the rear handle with your right hand and the front handle ("Loop") with your left hand.

Approach the hedge with the power tool in the idle setting and press the throttle before using the cutter. Never raise the engine speed without load. Always commence trimming with the cutters moving. Do not "stab" into the hedge with the tip of the cutter.

Never operate in the slipping range of the clutch. Damage through overload or overheating is excluded from our warranty.

Take particular care when working near wire fences and never touch the wire with the cutter.

Switch off the engine immediately the tool behaves in an unusual way or if cuttings have become entangled in the blade. Wait until the blade has stopped. When the **engine is switched off**, remove the entangled cuttings, undergrowth etc. Before starting up the tool again, check the entire power tool for safety.

### Trimming procedures

Cut the hedge in several stages, if the hedge needs to be cut back a great deal. Between the passes, cut back thicker branches and twigs with pruning shears neiden.

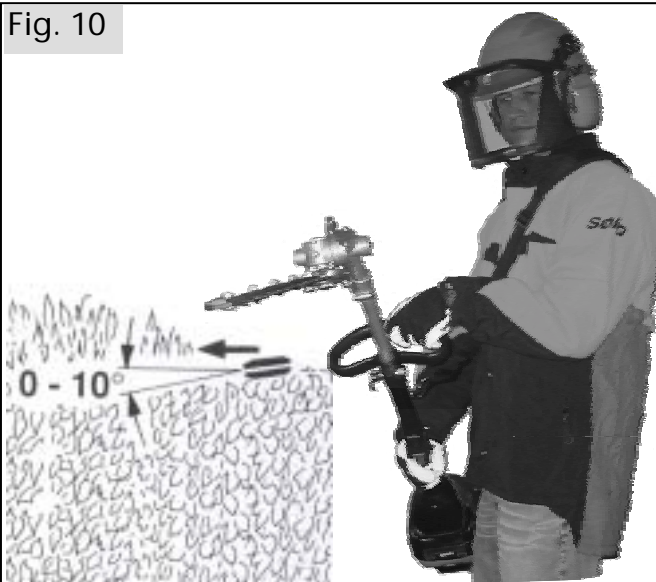

#### Cutting the top of the hedge

Holding the shears at an angle (max. 10°) at the top of the hedge, cut the hedge across to the opposite edge to allow the cuttings to fall to the floor. Recommended position of the angular gearbox: up to 45° angle to the hedge.

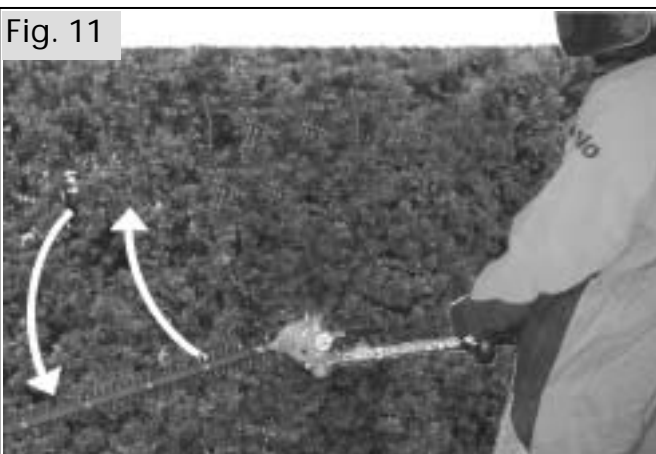

#### Cutting the side of the hedge

Move the shears forwards and backwards vertically to cut in arched movements, slowly advancing across the hedge.

Recommended position of the loop handle: turned 90° into the higher cut direction.

To prevent the need for users to position themselves immediately next to the hedge, we recommend the setting of the angular gearbox at a slight angle.

### 7.3 Decorative cutting

The trapezoidal cutting pattern shown prevents the lower hedge area from losing its foliage due to lack of light.

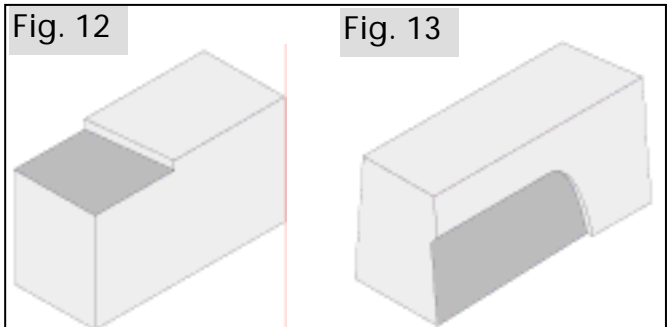
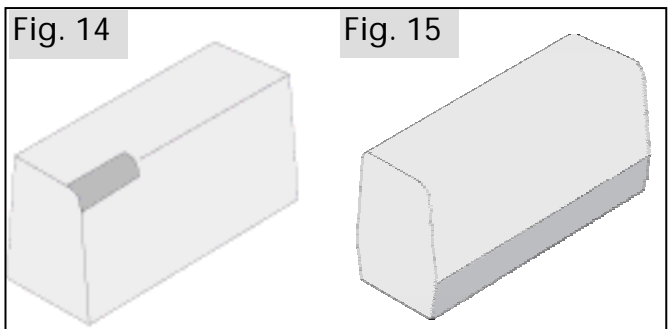

Fig. 12:

Firstly, cut the hedge to the desired height. Cuttings can be freed from the hedge by a slight pendulum action. To achieve a straight cut, a taut piece of string is positioned in the hedge at cutting height.

Fig. 13:

Cut the hedge from below upwards into a trapezoidal shape (to 1 m height, narrowed at the top by approximately 10 cm). This prevents cuttings falling onto that part of the hedge that has not yet been cut, which may disrupt further cutting.



Slightly bevel the top edge of the hedge; then cut back the bottom of the hedge near the ground.

The correct time for cutting hedges is:

Leaves: June and October

Needles: April and August

Fast growing hedges: approx. every 6 weeks from May onwards.

## 8. Operating and maintenance instructions

The maintenance and the repair of modern machines as well as their safety-relevant assemblies require qualified specialised training and a workshop equipped with special tools and test equipment. Consequently the manufacturer recommends that all tasks not described in these operating instructions be carried out by a specialised workshop. That specialist has the required training, experience, and equipment at his disposal, to provide you with the most cost-effective solution for such work. He will provide additional help in word and deed.

After a running-in time of app. 5 hours, all accessible screws and nuts (except the carburettor adjusting screws) must be checked for tightness and they must be retightened, if required.

### 8.1 Blade

Before hedge trimming and after cleaning, treat the clean blade with maintenance and treatment oil. We recommend the "Solo maintenance and treatment oil" (Part no: 00 83 163).

To clean the blade after hedge trimming, we recommend the use of "SOLO Universal-Reiniger (Cleaner)" (Part no: 00 83 116). After a short period of soaking in, the ingrained remains of cuttings on the blade are soft and solvent. They can then be removed easily with a cloth.

Check the blade at regular intervals and when cutters operate unusually or if the blades are jammed. For this, the engine must be switched off and the blade must be stopped. Clean cuttings, undergrowth etc. from the blade. Immediately replace blunt or damaged tools, even if only slightly damaged.

#### Sharpening the cutting blade

 Sharpening of the cutting blade must only be carried out by an authorised agent.

- Sharpening angle: 45°
- Always sharpen towards the cutting edge
- Only work with a forward stroke
- Following sharpening, remove the burr with a whetstone and spray the blade with a maintenance and treatment oil.

### 8.2 Gear lubrication

Re-lubricate the blade gearbox (8), angular gear (5) and clutch mid-section (12) with SOLO "Special gearbox flow grease" (part no. 00 83 180) approx. Every 20 operating hours.

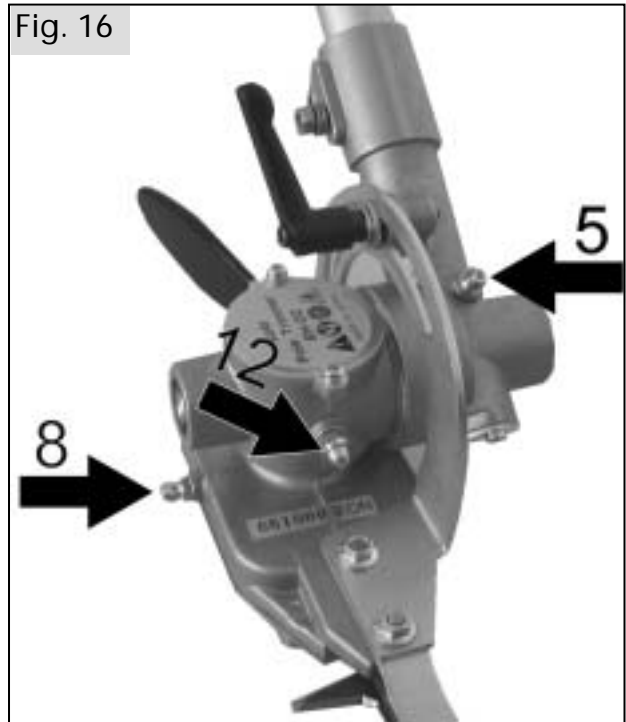

#### **Cutter gearbox:**

With a grease gun, press about 20g gearbox flow grease into the blade gearbox grease nipple (8) (3-5 shots).

#### **Angular gear:**

With a grease gun, press about 10 g gearbox flow grease into the angular gear grease nipple (5) (2-3 shots).

#### **Clutch mid-section:**

With a grease gun, press about 20g gearbox flow grease into the clutch mid -section grease nipple (12) (3-5 shots).

### 8.3 Air Filter Maintenance

Contaminated air filters cause a reduction in engine performance and increase fuel consumption with more pollutants in the exhaust gas. Engines are less likely to start readily with a contaminated air filter. Carry out the following maintenance jobs regularly.

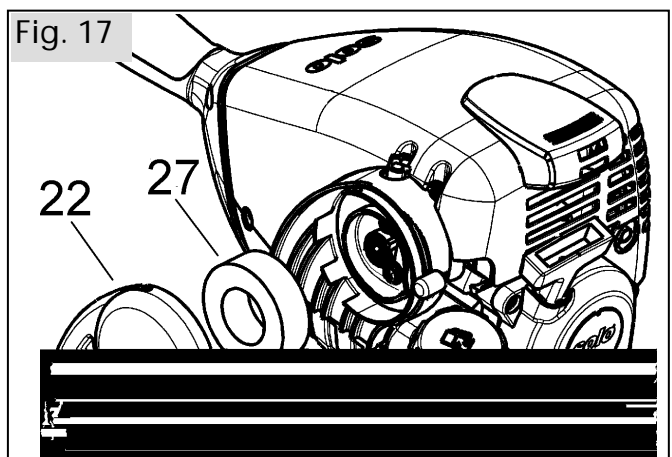

Before opening the air filter, close the choke  to prevent dirt entering the carburettor. Turn air filter lid (22) clockwise (viewed onto the air filter lid), and remove the lid. Remove foam filter (27) from the lid and clean the area around the filter.

Clean the foam filter daily, if the equipment is used all day. Clean more frequently, if you are working under very dusty conditions. Simply knocking the filter casing or blowing dust from the filter bowl are the best methods of daily maintenance. Immediately replace the foam filter, if it shows any sign of damage. Engine failure due to incorrect maintenance and care are excluded from our warranty.

Insert the new or cleaned foam filter into the air filter lid. Position the lid onto the filter casing, guided by the guide spigot, and lock into place with an anti-clockwise rotation.

Never insert moist or wet foam filters!

### 8.4 Carburettor adjustment

The carburettor has been adjusted optimally at the factory. Subject to the operational altitude (mountains or low lying areas), the carburettor may require readjustment.

If the idle speed is correctly adjusted, the engine should run without moving the blade. Slight adjustments of the idle throttle into the average idle speed given in the specification can be made via the idle stop screw "T" by following the instructions below (the use of a tachometer is recommended):

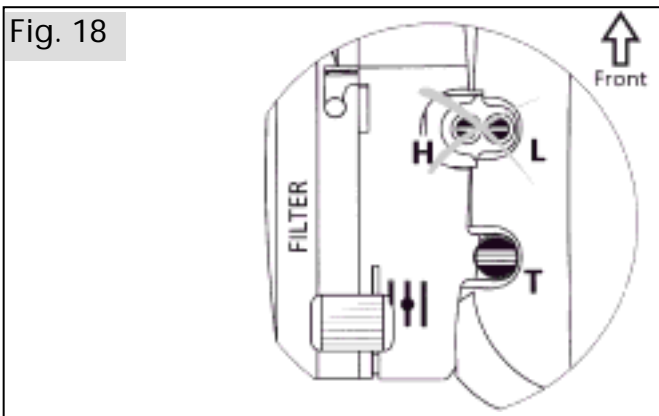

The air filter must be clean to ensure correct idle speed adjustment. Let the engine run until it is warm, before making any adjustments.

- If the engine idles too fast (in particular if the power tool has already operated at idle speed), turn the idle speed stop screw "T" anti-clockwise.
- If the engine idles too slowly (i.e. the engine always dies in idle), turn the idle speed stop screw "T" clockwise a little, until the engine runs smoothly.

 Under no circumstances must the cutter be driven at idle speed!

**Only qualified mechanics must adjust the regulating screws for idle mixture "L" and full load mixture "H".**

If the idling speed cannot be set correctly with the idling end-stop screw "T", request an authorised service centre to tune the carburettor.

**The following instructions are for authorised service shops**

D-CUT carburettors:

Use the D-CUT carburettor key to adjust the idle mixture screw "L" and the full load mixture screw "H". Check with our customer service team regarding the basic setting.

Carburettors with limiter caps:

The regulating screws for idle mixture and full load mixture can only be adjusted in a limited range.

 The carburettor is tuned for optimum engine performance. Use a rev counter to tune the carburettor correctly!

Do not adjust the engine to a higher speed. Excessive engine speed can lead to major engine damage!

### 8.5 Information about the spark plug

Check the spark plug regularly after 50 hours of operation.

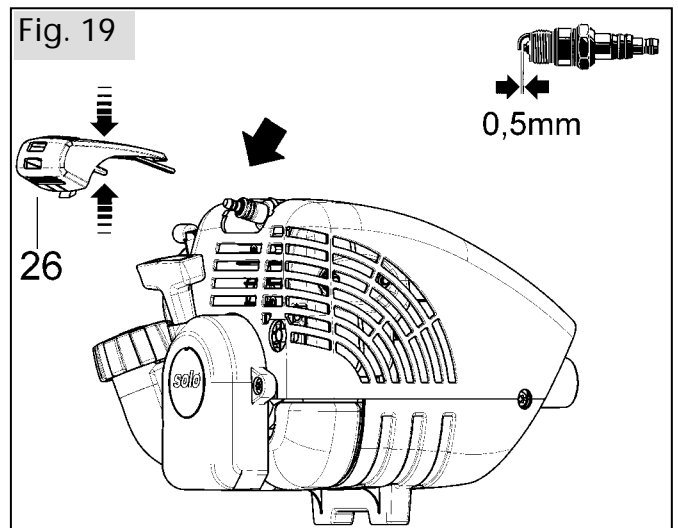

- Press the spark plug cover (26) together at the top and bottom, and move it away from the engine casing by pushing it back.
- Disconnect the spark plug cap.
- Unscrew the spark plug and dry the electrodes.

The spark plug should be replaced after 100 hours of operation or if the electrodes are badly worn.

Do not turn the engine over while the spark plug has been removed or the spark plug cap has been

disconnected from the high-tension ignition cable. A spark may cause a fire!

Spark plugs with resistor (thermal value 200) are available in different brands under the following description:

BOSCH            WS6F  
CHAMPION       RCJ-6Y or comparable.

The correct electrode gap is 0.5 mm.

Only use spark plugs, where the contact nut has been firmly fitted. Loose connectors may produce sparks, which can cause a fire.

- Insert the spark plug into the cylinder head and tighten it.
- Push the spark plug cap firmly over the spark plug.
- Fix the spark plug cover with the side tabs to the corresponding grooves on the engine casing and snap them into place on the engine casing.

Before restarting the engine, check the high-tension ignition cable for any damage to its insulation and ensure the cable is connected securely to the plug cap.

### 8.6 Information about the silencer

Ensure the silencer is in perfect condition before operating the machine. Never touch the silencer while it is still hot.

Unsatisfactory engine performance, despite a clean air filter and a correctly adjusted carburettor, may well be due to a partially blocked or damaged silencer. Please consult your specialist service centre.

### 8.7 Replacing the fuel filter

We recommend having the fuel filter changed annually by a specialised service centre.



A trained mechanic can carefully remove the fuel filter via a wire loop through the fuel tank filler. Ensure that the thicker part of the fuel hose on the tank wall is not drawn into the fuel tank.

### 8.8 Shutdown and storage

Preferably, store the equipment in a dry and secure place with a full fuel tank. Open flames or similar must not be nearby. Prevent unauthorised use – particularly by children.

For stops longer than four weeks the following steps should be carried out:

- Empty and clean the fuel tank at a well-ventilated location.
- Start the engine with an empty fuel tank. Run the engine until the carburettor is empty and the engine stalls. Otherwise the carburettor nozzles could become encrusted with residual fuel mixture and make a subsequent start harder.
- Clean the power tool well (particularly the air intake openings, the cylinder fins, the air filter and the fuel filler area).
- Clean and maintain the cutter.  
We recommend: clean with "SOLO chainsaw/saw cleaner" (Part no: 00 83 116) and treat with "SOLO maintenance and care oil" (Part no: 00 83 163).

### 8.9 Scheduled maintenance

The following information is based on standard operating conditions. For special conditions, such as prolonged daily use, the recommended maintenance intervals should be reduced accordingly.

		after the first 5 hours	daily	after every 10 - 20 hours	after every 50 hours	after every 100 hours	as required	annually
<b>Carburettor</b>	Check idling speed		X					
	Adjust idling speed						X	
<b>Air filter</b>	Clean		X					
	Replace						X	
<b>Spark plug</b>	Check the electrode gap and adjust, if required				X			X
	Replace					X	X	
<b>Gearbox lubricant</b>	Top up			X			X	X
<b>Blade</b>	Check		X					
	Clean and maintain		X				X	X
	Replace						X	
<b>Cooling air intake</b> [casing apertures between the anti-vibration system (24) and the engine casing]	Clean		X				X	X
<b>Cylinder fins</b>	Clean						X	X
<b>Fuel tank</b>	Clean				X			X
<b>Fuel filter</b>	Replace							X
<b>All accessible screws</b> (except for adjusting screws)	Retighten	X					X	X
<b>Controls</b> (stop switch, throttle lever, half throttle detent, starter)	Check function		X					
<b>Silencer</b>	Visual inspection		X					
<b>Complete machine</b>	Visual inspection		X					
	Clean			X			X	X

Implement all maintenance jobs regularly. If required, authorise a specialist service centre to maintain the machine for you. The owner of the machine is responsible for:

- Any damage caused by a lack of maintenance, incorrect or late maintenance and repairs
- Consequential losses - including corrosion - from incorrect storage

## 9. Specification

Engine type		SOLO single cylinder two-stroke engine
Engine capacity	cm <sup>3</sup>	29
Bore / stroke	mm	35 / 30
Engine power	kW at rpm	1,0 / 7500
Max. permissible speed no load with cutter	rpm	9000
Medium idling speed	rpm	2800
Fuel tank capacity	l	0,5
Fuel mix ratio:	with <b>SOLO 2T engine oil</b> with other two-stroke oils	1:50 (2%) 1:25 (4%)
Carburettor		All-position diaphragm carburettor with primer and integrated fuel pump
Air filter		Foam filter
Ignition		Electronically controlled magneto ignition, maintenance free
Total cutting blade length/Effective cutting length	mm	560 / 536
Number of individual cutters top/lower blade		36 / 36
Distance between individual cutters	mm	30
Blade stroke	mm	15
Blade sharpening angle		45°
Gear reduction		1:4
Total adjustable angle upward (in the direction of the loop handle)/downward		135° 90° / 45°
Weighted effective acceleration (ISO 7916) Handle r.h. side / handle l.h. side	m/s <sup>2</sup>	3,2 / 5,0
Sound pressure level LP <sub>eg</sub> (EN 27917)	dB(A)	90
Sound power level L <sub>Weg</sub> to EN ISO 3744 actual / guaranteed 95%	dB(A)	106 / 110
Dimensions	mm	
	Height	220
	Width	230
	Length	1690
Weight ready to operate (tank empty)	kg	6,2



## 10. Accessories

Accessories	Part no.
SOLO 2T engine oil 100 ml	00 83 103
SOLO 2T engine oil 1 l	00 83 104
SOLO 2T engine oil In a metering bottle 1 l	00 83 105
"SOLO Universal-Reiniger" 500 ml	00 83 116
SOLO maintenance and treatment oil spray can 300 ml	00 83 163
SOLO gear grease for hedge trimmer	00 83 190
Grease gun	00 80 432
Gloves SOLO Fit	99 390 1200
SOLO leather forest boots	99 305 00 + size (36 - 48)
SOLO protective helmet with face and ear protection	99 390 1100
SOLO forest and countryside work jacket EN 340	99 303 000 + size (2[s] - 6[xxl])
SOLO Outdoor Knee-breeches	99 020 95 + size
SOLO Outdoor dungarees	99 020 94 + size

## 11. Parts subject to wear and tear

Various parts are subject to application-specific or normal wear and must be replaced in good time, when required. The following parts are subject to normal wear and are not covered by the manufacturer's guarantee:

- Air filter
- Fuel filter
- All rubber parts which come into contact with fuel
- Clutch
- Spark plug
- Starter
- Cutting tools

## 12. Guarantee

The manufacturer guarantees trouble-free quality and will cover the cost of replacing parts which are found to be faulty in material or workmanship within the prescribed guarantee period after the date of purchase. Please note that specific guarantee conditions may vary from country to country. If in doubt, ask your equipment vendor. He is responsible for guarantee matters.

We hope you will understand that we cannot be liable for damage resulting from the following causes:

- Non-compliance with the operating instructions.
- Neglecting essential maintenance and repair work.
- Damage caused by incorrect carburettor adjustment.
- Wear in normal use.
- Obvious overload by continuously exceeding the maximum performance limit of the product.
- Using non-authorized tools.
- Use of force, incorrect treatment, misuse and accidents.
- Damage from excessive heat due to dirt build-up around the cooling fan housing.
- Attempted adjustments and repairs by unqualified persons.
- Use of unsuitable spare parts or third party parts, if these are the cause of the defect.
- Use of unsuitable or stale fuel.
- Damage caused by using the product in the hire or rental industry.

Normal cleaning, adjustments or maintenance work fall outside the guarantee provisions.

A service centre authorised by the manufacturer must carry out all guarantee work.

In the best interest of continued technological progress we reserve the right to change the design and configuration of any product without prior notice.

For that reason, no claims can be accepted with reference to text and illustrations in this manual.

Made in Germany



SOLO  
Postfach 60 01 52  
D 71050 Sindelfingen  
  
Tel. 07031-301-0  
Fax 07031-130  
info@solo-germany.com

SOLO  
P.O.Box 60 01 52  
D 71050 Sindelfingen  
Germany  
Phone+49-7031-301-0  
Fax +49-7031-149  
export@solo-germany.com

## Free Manuals Download Website

<http://myh66.com>

<http://usermanuals.us>

<http://www.somanuals.com>

<http://www.4manuals.cc>

<http://www.manual-lib.com>

<http://www.404manual.com>

<http://www.luxmanual.com>

<http://aubethermostatmanual.com>

Golf course search by state

<http://golfingnear.com>

Email search by domain

<http://emailbydomain.com>

Auto manuals search

<http://auto.somanuals.com>

TV manuals search

<http://tv.somanuals.com>