

Digital Color Printer

Instructions for Use

CE

UP-D55

Owner's Record

The model and serial numbers are located at the rear. Record these numbers in the space provided below. Refer to these numbers whenever you call upon your Sony dealer regarding this product.

Model No. _____

Serial No. _____

WARNING

To prevent fire or shock hazard, do not expose the unit to rain or moisture.

To avoid electrical shock, do not open the cabinet. Refer servicing to qualified personnel only.

THIS APPARATUS MUST BE EARTHED.



This symbol indicates the equipotential terminal which brings the various parts of a system to the same potential.



This symbol is intended to alert the user to the presence of important operating and maintenance (servicing) instructions in the literature accompanying the appliance.

For the customers in the U.S.A.

This equipment has been tested and found to comply with the limits for a Class A digital device, pursuant to Part 15 of the FCC Rules. These limits are designed to provide reasonable protection against harmful interference when the equipment is operated in a commercial environment. This equipment generates, uses, and can radiate radio frequency energy and, if not installed and used in accordance with the instruction manual, may cause harmful interference to radio communications. Operation of this equipment in a residential area is likely to cause harmful interference in which case the user will be required to correct the interference at his own expense.

You are cautioned that any changes or modifications not expressly approved in this manual could void your authority to operate this equipment.

The shielded interface cable recommended in this manual must be used with this equipment in order to comply with the limits for a digital device pursuant to Subpart B of Part 15 of FCC Rules.

For the customers in Canada

This unit has been certified according to Standard CSA C22.2 NO.60601.1.

For the customers in the U.S.A and Canada

Model UP-D55 is Non-Patient Equipment. This unit can not be used in the vicinity of patients.

* Patient Vicinity

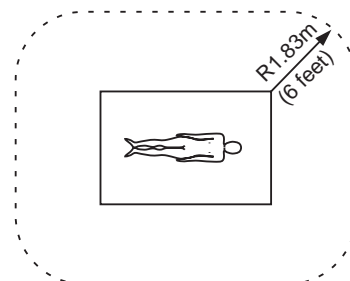

Important safeguards/notices for use in the medical environments

1. All the equipments connected to this unit shall be certified according to Standard IEC60601-1, IEC60950, IEC60065 or other IEC/ISO Standards applicable to the equipments.
2. When this unit is used together with other equipment in the patient area*, the equipment shall be either powered by an isolation transformer or connected via an additional protective earth terminal to system ground unless it is certified according to Standard IEC60601-1.

* Patient Area

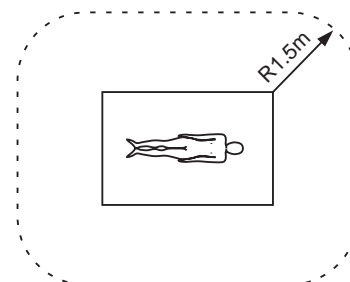

3. The leakage current could increase when connected to other equipment.
4. This equipment generates, uses, and can radiate frequency energy. If it is not installed and used in accordance with the instruction manual, it may cause interference to other equipment. If this unit causes interference (which can be determined by unplugging the power cord from the unit), try these measures: Relocate the unit with respect to the susceptible equipment. Plug this unit and the susceptible equipment into different branch circuit.

Consult your dealer. (According to standard EN60601-1-2 and CISPR11, Class B, Group 1)

Caution

When you dispose of the unit or accessories, you must obey the law in the relative area or country and the regulation in the relative hospital.

Warning on power connection

Use a proper power cord for your local power supply.

1. Use the approved Power Cord (3-core mains lead) / Appliance Connector / Plug with earthing-contacts that conforms to the safety regulations of each country if applicable.
2. Use the Power Cord (3-core mains lead) / Appliance Connector / Plug conforming to the proper ratings (Voltage, Ampere).

Warning on power connection for medical use

Please use the following power supply cord. With connectors (plug or female) and cord types other than those indicated in this table, use the power supply cord that is approved for use in your area.

| | United States | Canada |
|-------------------------|---|--|
| Plug Type | HOSPITAL GRADE* | HOSPITAL GRADE* |
| Female end | E62405, E35708 | LR53182, LL022442, LL088408 |
| Cord type | E159216, E35496 Min.Type SJT Min.18 AWG | LL112007-1, LL20262, LL32121, LL84494 Min.Type SJT Min.18AWG |
| Minimum cord set rating | 10A/125V | 10A/125V |
| Safety approval | UL Listed | CSA |

*Note: Grounding reliability can only be achieved when the equipment is connected to an equivalent receptacle marked 'Hospital Only' or 'Hospital Grade'.

Table of Contents

Getting Started

| | |
|---|----------|
| System Overview | 5 |
| System Configuration | 5 |
| Location and Function of Parts and Controls | 5 |
| Front Panel | 5 |
| Rear Panel | 6 |
| Supplied Accessories | 6 |
| Connections | 7 |
| USB Port Connection | 7 |
| Installing the Printer Driver | 7 |

Operation

| | |
|---------------------------------------|-----------|
| Before Printing | 9 |
| Loading an Ink Ribbon Cartridge | 9 |
| Inserting the Paper Tray | 12 |
| Printing | 13 |

Miscellaneous

| | |
|--|-----------|
| Precaution | 15 |
| Safety | 15 |
| Installation | 15 |
| Before Transporting the Printer | 15 |
| Cleaning | 15 |
| Ink Ribbon and Paper | 16 |
| Specifications | 16 |
| Troubleshooting | 17 |
| Indicators on the Ribbon Door | 18 |
| If the Paper Jams | 19 |
| Index | 21 |

System Overview

The UP-D55 digital color printer is designed to reproduce computer images on A-5 size paper. You can print out computer image data in full color (with 256 shades per color, a total of more than 16,700,000 colors in all) in high resolution print mode (approximately 379 dpi).

System Configuration

The following shows an example of a printer system configuration.

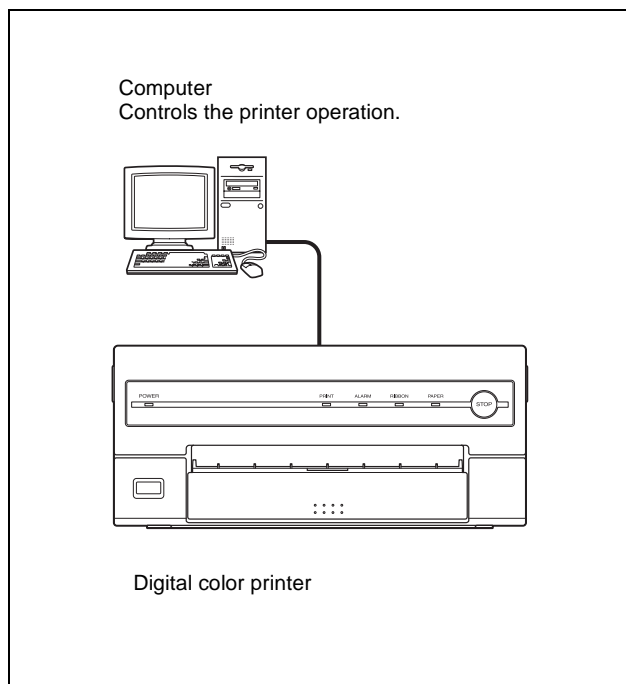

Location and Function of Parts and Controls

For details, refer to the pages given in parentheses.

Front Panel

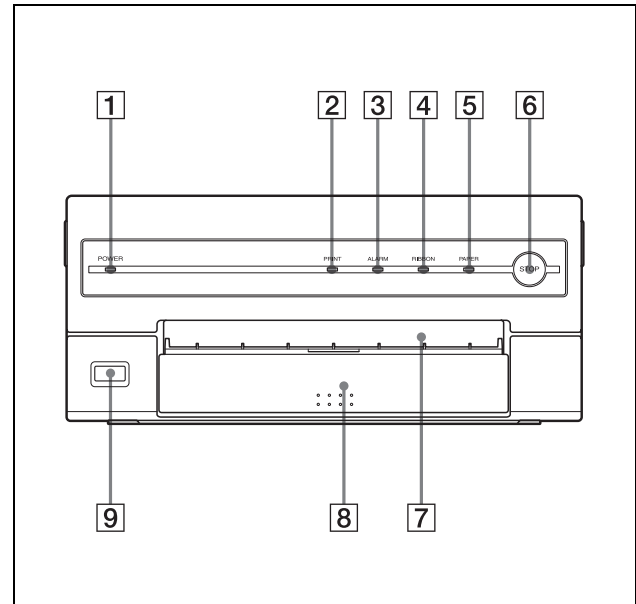

- 1 POWER indicator**
Lights when the POWER switch of the printer is set to ON.
- 2 PRINT indicator (18)**
Lights while the printer is printing.
- 3 ALARM indicator (18)**
Lights in orange in case of paper jamming or occurrence of any other problem.
- 4 RIBBON indicator (18)**
Lights when a problem for ink ribbon occurs.
- 5 PAPER indicator (18)**
Lights when a problem for paper occurs.
The printer allows you to check the printer operating condition according to the lighting conditions of the PRINT indicator, ALARM indicator, PAPER indicator and RIBBON indicator. For details, see “Indicators on the Ribbon Door” on page 18.
- 6 STOP button (14)**
Press this button to stop printing multiple copies of identical printouts. The printer finishes printing the current copy and ejects it. Then the printer turns to stand by mode.

- 7 Paper output slot**
Printed pages are ejected here.
- 8 Paper tray (13)**
Load paper into this tray.
- 9 ① POWER switch (13)**
Press this switch to turn the printer on or off.

Rear Panel

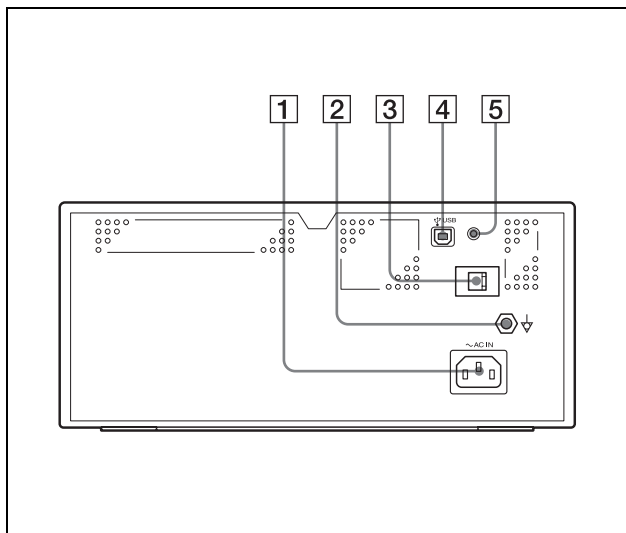

- 1 ~ AC IN connector**
Use a proper power cord for your local power supply (not supplied).
Refer to “Warning on power connection” on page 3 and “Warning on power connection for medical use” on page 3.
- 2 ⚡ Equipotential ground terminal connector**
Used to connect to the equipotential plug to bring the various parts of a system to the same potential. Refer to “Important safeguards/notices for use in the medical environments” on page 2.
- 3 USB cable clamp**
Used to secure the USB cable.
- 4 Ⓜ (USB) connector (7)**
Connects to a computer or another USB peripheral device with a USB cable (supplied).
- 5 Switch**
Not used at present.

Supplied Accessories

The printer is packed together with the following accessories. Check that nothing is missing from your package.

Paper Tray (1)

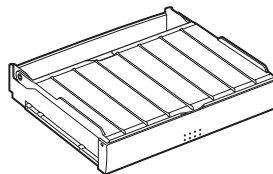

Ink ribbon holder (1)

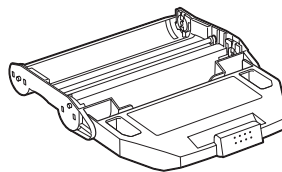

USB connecting cable (1)
Software Licence Agreement (1)
CD-ROM (including the printer drivers and PDF files of multi-lingual Instructions For Use) (1)
Before Using this Printer (1)

Notes

- Retain the original carton and packing materials in case you have to transport the unit in the future.
- Remove the ink ribbon cartridge and paper tray when transporting the printer.

Connections

After connecting the USB connecting cable (supplied) to the printer and the computer, connect the power cord. For details about the printer connection, refer to the manuals for the computer or other peripheral devices.

Notes

- Before connecting the printer to the computer, turn off the printer, computer, monitor, and all peripheral devices connected to the computer.
- Before connecting the printer to the computer, disconnect the power cord from the printer. Connect the power cord to the printer only after connecting the printer and the computer.
- Follow the connection procedures described in the computer manual.
- Make sure that the interface cable is connected securely at both ends.
- The printer drive software provided with the printer is not suitable for using the printer connected to a network.
- Operation of the printer is not guaranteed for connection to a USB hub.

USB Port Connection

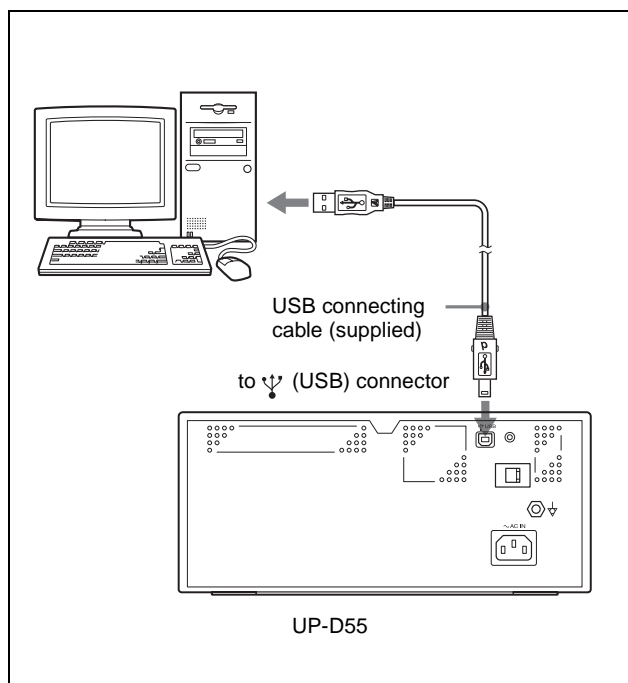

Installing the Printer Driver

Install the printer driver provided with the printer. For detailed instructions on how to install the printer driver, refer to the Readme.txt file on the printer driver installer disc.

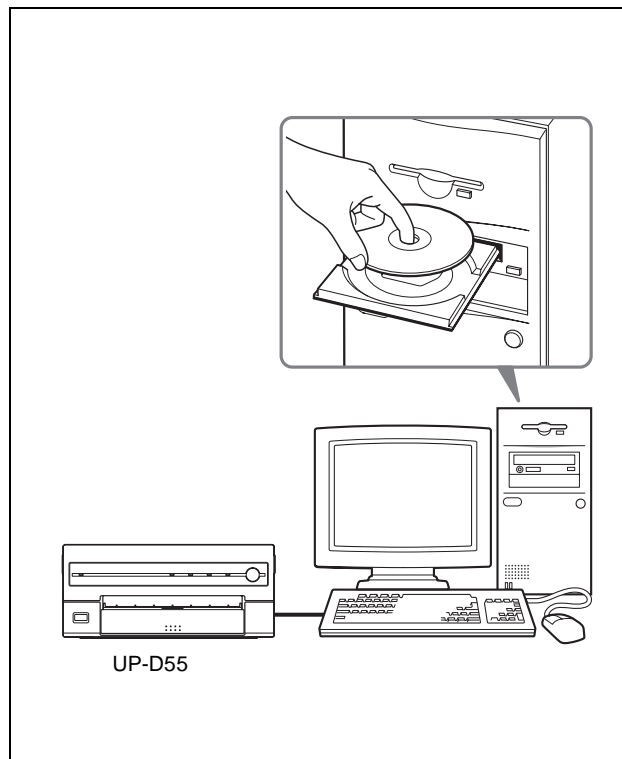

About USB (Universal Serial Bus) Specification Revision 2.0

- The UP-D55 complies with the USB 2.0 specification.
- USB 2.0 is a newer standard than USB 1.1, but provides backward compatibility.
- USB 2.0 supports Hi-speed USB, in addition to the existing Full (Low) speed.
- The UP-D55 can be connected as Full-speed in a USB 1.1 environment. However, to use the UP-D55 with Hi-speed USB functions in a USB 1.1 environment, the following requirements must be met.
 - Computer
A computer which supports Hi-speed USB (conforming to the USB 2.0 specification) ^{a)}
 - OS
Windows 2000/Windows XP
 - USB 2.0 device driver
USB 2.0 device driver produced by Microsoft Corporation. (Operation using USB 2.0 drivers other than ones produced by Microsoft Corporation is not guaranteed.)
 - USB 2.0 cable
Use the 2-m cable supplied with the UP-D55.

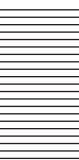
- 
- a) Operations of all of devices which conform to USB 2.0, or all USB 2.0 extension boards/extension cards cannot be guaranteed.

Note

When the UP-D55 is connected to the computer with the power turned on, do not turn your computer to standby mode (suspend status) or in pause mode. Doing so may cause a malfunction of the operation.

Before Printing

This section describes the operations below that must be made before printing, but after making the necessary connections. (See “Connections” on page 7.)

- Loading an ink ribbon cartridge (See below.)
- Inserting the paper tray (See page 12.)

Once the above operations have been completed, there should be no need to repeat them during routine printing. Perform them only as necessary.

Notes

- You can replace the ink ribbon or load paper regardless of whether the power is on or off.
- When either an ink ribbon or paper has been exhausted, **replace both the ink ribbon and paper at the same time.**
- Use only ink ribbon and paper designed for use with this printer. Failing to do so is likely to result in malfunctions. (See “Ink Ribbon and Paper” on page 16.)

Loading an Ink Ribbon Cartridge

To make printouts, an ink ribbon cartridge (an ink ribbon holder which has been loaded with an ink ribbon) and paper must be loaded. This section describes how to set the ink ribbon into the supplied ink ribbon holder and to load the ink ribbon cartridge in the printer.

When you use the printer for the first time, start the operation to load the ink ribbon cartridge from step 4.

Notes

- **When you use the printer for the first time, the thermal head may be out of position. Before attempting to load the ink ribbon cartridge, turn on the power under the condition where the ribbon door is closed so that the thermal head is placed at the correct position.**
- If a blank sheet of paper is ejected, and the RIBBON indicator lights, the ink ribbon has been exhausted. Replace the paper together with the ink ribbon. Do not reuse the ejected blank paper.
- Once an ink ribbon has been completely used up, replace it. An ink ribbon is not reusable.
- Do not rewind the ink ribbon for reuse.
- Do not touch the ink ribbon or place it in a dusty location. Finger prints or dust on the ink ribbon will result in imperfect printing or malfunction of the head.

- 1 Open the ribbon door by pulling the ribbon door toward you.

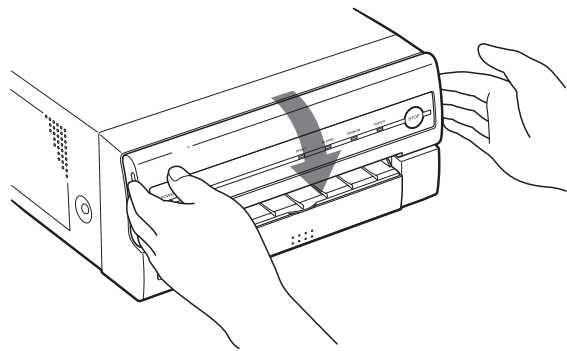

- 2 Remove the ink ribbon cartridge.

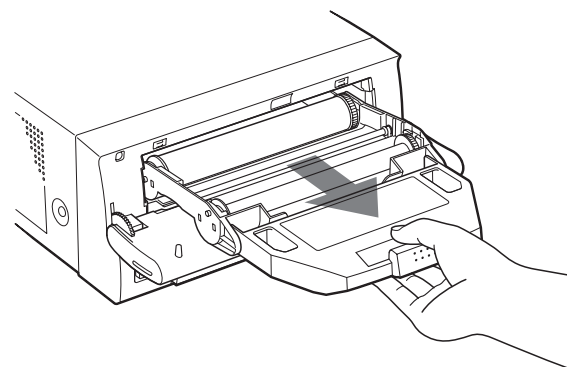

If you can not remove the ink ribbon cartridge

The thermal head may be out of position.

In such a case, close the ribbon door, and turn the power off, then back on again. After a while, start the operation from step 1 again.

- 3** Detach the spent ink ribbon from the ink ribbon holder.

Pushing the ink ribbon spool that takes up the ink ribbon in the direction of the arrow, remove the spool from the side with the gray gear.

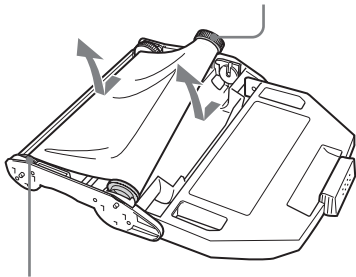

Pushing the ink ribbon spool that sends the ink ribbon in the direction of the arrow, remove the spool from the side with the white gear.

- ②** Place the ink ribbon with the white gear as illustrated.

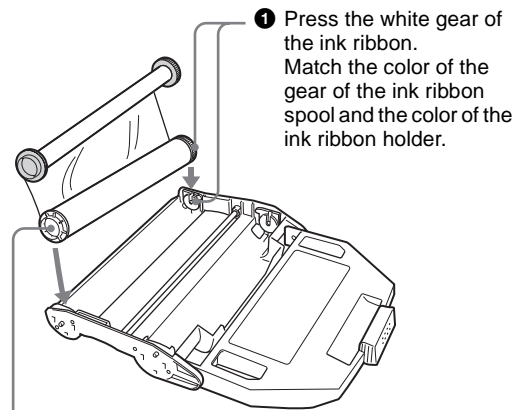

- ①** Press the white gear of the ink ribbon. Match the color of the gear of the ink ribbon spool and the color of the ink ribbon holder.

- ②** Press the other side of the ink ribbon until you hear it click into place.

- 4** Load the new ink ribbon into the ink ribbon holder.

- ①** Holding the ink ribbon firmly, remove the gear cover.

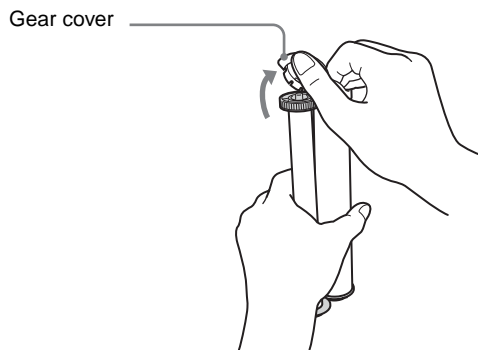

To avoid dropping the ink ribbon, make sure that you hold it firmly.

- ③** Place the ink ribbon with the gray gear in the same way as explained in step **②**.

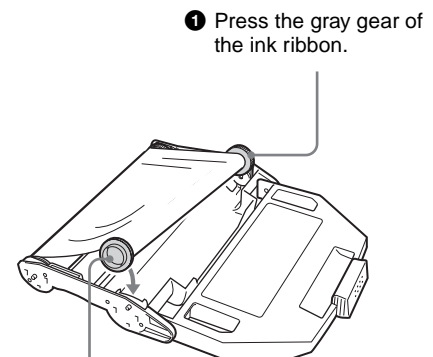

- ①** Press the gray gear of the ink ribbon.

- ②** Press the other side of the ink ribbon until you hear it click into place.

- ④** Eliminate any slack in the ribbon by turning the gears.

Note

If the ribbon is left slack, it may be damaged when the ink ribbon cartridge is inserted into the printer.

Turn the gears in the direction of the arrows until any slack is eliminated and the magenta section of the ink ribbon appears.

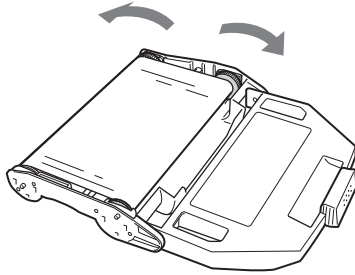

5 Insert the ink ribbon cartridge until it stops.

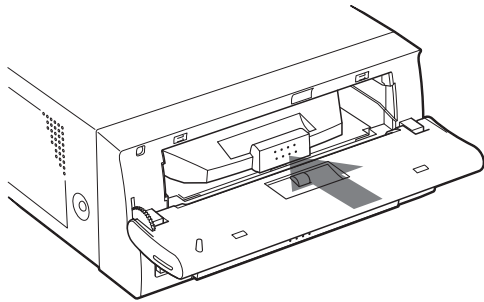

If the ink ribbon cartridge cannot be inserted

In such a case, close the ribbon door, and turn the power off, then back on again. Insert the ink ribbon cartridge again.

6 Close the ribbon door.

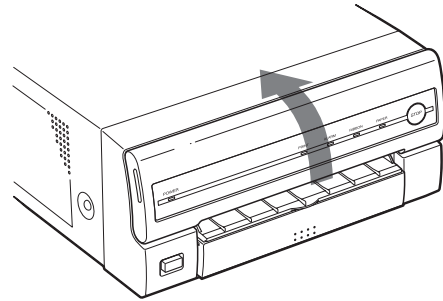

Notes

When handling the ink ribbon:

- Do not rewind the ink ribbon for reuse.
- When handling the ink ribbon, be careful not to touch the surface of the ink ribbon. Dust or finger prints are likely to cause unsatisfactory printing or malfunction of the head.

When storing ink ribbon:

- Avoid placing the ink ribbon in a location subject to:
 - high temperatures
 - high humidity
 - excessive dust
 - direct sunlight
- Store a partially used ink ribbon in its original packaging.

If your ink ribbon should tear

Repair the tear with transparent tape. There should be no problem with using the remaining portion of the ribbon.

Transparent tape

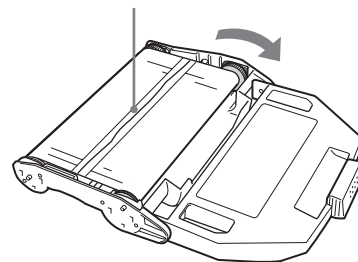

Turn the gray gear of the spool that takes up the ink ribbon in the direction of the arrow to remove any slack until the transparent tape cannot be seen.

Inserting the Paper Tray

To load paper in the paper tray and insert the paper tray into the printer, follow the procedure below. Be careful not to touch the printing surface of the paper. When you use the printer for the first time, start the operation to insert the paper tray from step 2.

Notes

- Use only the paper recommended. Failing to do so is likely to result in malfunctions such as paper jams. (See “Ink Ribbon and Paper” on page 16.)
- When a blank sheet of paper is ejected and the RIBBON indicator lights, the ink ribbon has been exhausted. Replace the paper together with the ink ribbon. Do not use the ejected blank paper.
- Be careful when removing and inserting the paper tray. If you are not careful, you may drop the printer.

- 1 Push the paper tray to remove it.

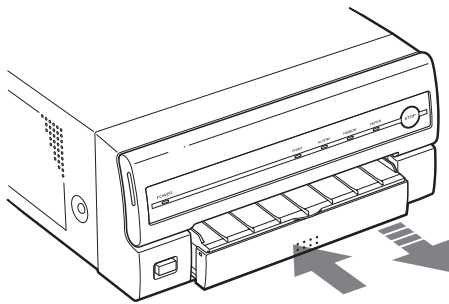

- 2 Place the paper in the paper tray so that the printing surface faces up with the protection sheet on top.

Notes

- Do not add only the paper. When the paper supply has been exhausted, replace both the ink ribbon and paper at the same time. If you add paper while printing, this may cause the paper jam.
- When handling the paper, do not touch the printing surface. Dust or finger prints are likely to cause unsatisfactory printing or malfunction of the head. Grasp the paper by the printing surface protection sheet.
- Load the paper so that it lays flat in the paper tray. If the paper is curled, it will overflow from the paper tray and paper may not be fed properly. Be

sure to riffle the paper along with the protection sheets before placing the paper in the paper tray.

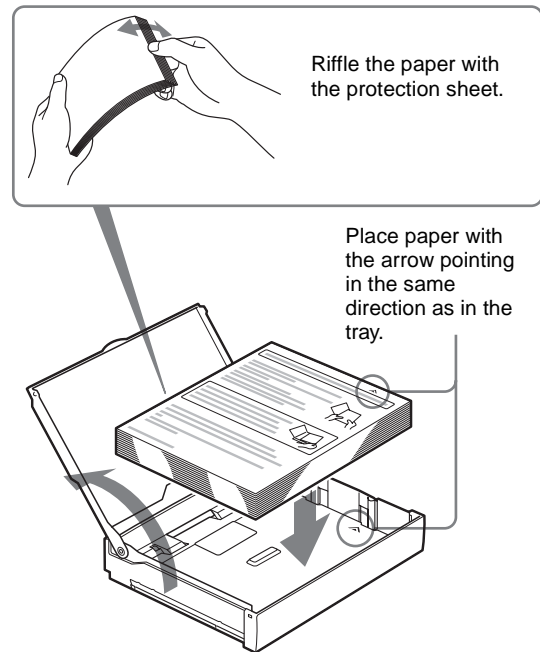

- 3 Remove the protection sheet placed on the top of the paper.

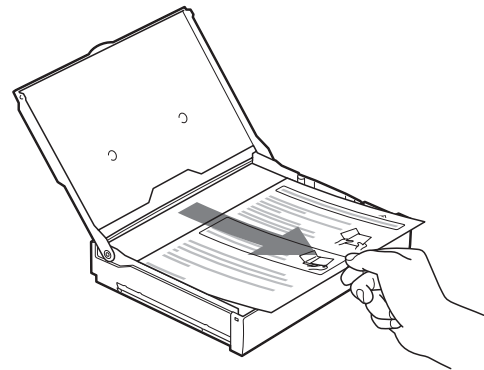

- 4 Slide the paper tray back into the printer until it clicks into place.

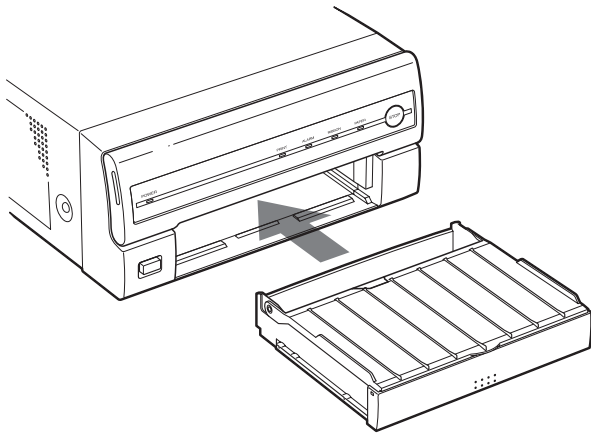

Note

If you cannot insert the ink ribbon cartridge completely, check whether any paper is left inside the printer. If you find a left sheet, slowly pull it straight out.

When storing the paper

- Avoid storing the paper in a location subject to:
 - high temperatures
 - high humidity
 - excessive dust
 - direct sunlight
- Use the original package for storing unused paper.

Printing

Before printing

- Ensure that the printer is properly connected to the computer. (See page 7.)
- Ensure that the ink ribbon cartridge and paper tray are properly loaded. (See pages 9 and 12.)
- Ensure that the printer driver has been installed. (See page 7.)

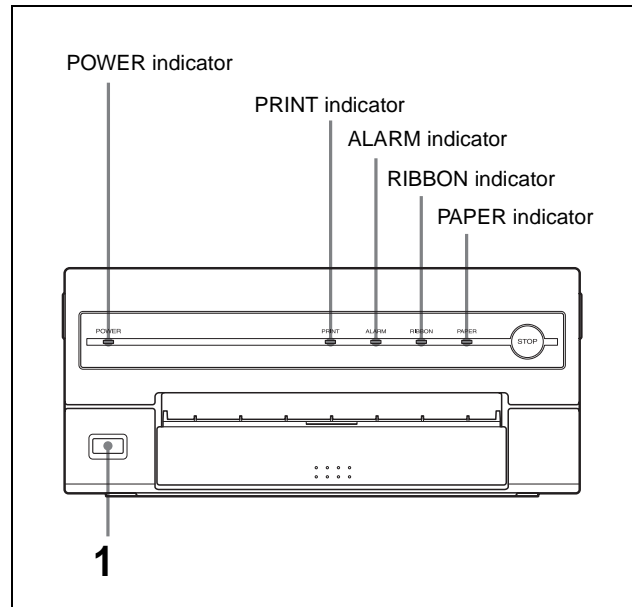

- 1 Press the POWER switch to turn the printer on. The POWER indicator lights. PRINT, ALARM, RIBBON and PAPER indicators light at the same time, then all of them go out.

Notes

- Turn the printer on first.
- Do not turn the computer off and on while it is accessing a hard or floppy disk.

- 2 Turn on the power of the computer.
- 3 Execute the print job with software application. While the printer is receiving the image data from the computer, the PRINT indicator blinks. While the printer is printing, the PRINT indicator lights.

Notes

- **Do not pull the paper out till the printer finishes printing.**
- Do not turn off the power during printing. If you do so, paper may not be ejected and may jam in the printer.
- Do not open the ribbon door while the printer is printing. If you open the ribbon door, the printer stops printing. When you close the ribbon door, the sheet

being printed when you opened the ribbon door is ejected and the printer turns to the standby mode.

- You can make multiple copies of identical printouts. However, the printer may stop printing due to warping of the printed sheet and the ALARM indicator lights. In such a case, remove the printouts accumulated on the paper tray. The printer will start to print the remaining copies automatically.
- Do not leave more than 10 sheets of ejected printouts on the paper tray. Doing so may cause a paper jam.

If the printer does not print

The printer will fail to print when the ALARM, PAPER, and/or RIBBON indicator light.

For details, see “Indicators on the Ribbon Door” on page 18.

If the paper or ink ribbon runs out during printing

The printer stops the printing operation.

Load the paper into the paper tray and the ink ribbon.

Printing of remaining copies is automatically started.

To stop the printing multiple copies of identical printouts

Press the STOP button. The printer finishes current printing and ejects it. Then, it turns in standby mode.

When storing your printouts

- Avoid storing the printout in a location subject to high temperatures, high humidity, excessive dust and direct sunlight.
- Do not stick tape on a printout. Also, avoid leaving a plastic eraser on a printout or placing a printout in contact with materials which contain plasticizer (under a desk mat, for example).

Precaution

Safety

- Operate the printer using the power source specified in “Specifications” on page 16.
- Be careful not to damage the AC power cord by placing or dropping heavy objects on it; it is dangerous to use the unit with a damaged AC power cord.
- If you do not intend to use the unit for a long time, disconnect the AC power cord.
- Unplug the AC power cord by grasping the plug, not the cable itself.
- Do not disassemble the unit.
- Do not remove the cover. There is a danger of electric shock from the internal parts.
- Be careful not to spill water or other liquids on the unit, or to allow combustible or metallic material to enter the cabinet. If used with foreign matter in the cabinet, the unit is liable to fail, or present a risk of fire or electric shock.
- Ventilation holes are provided to prevent the unit from overheating. Be careful not to obstruct them with other units or by covering the unit with a cloth, etc.
- If the unit malfunctions or if a foreign body falls into the cabinet, disconnect the AC power cord immediately and consult your Sony service facility or your Sony dealer.

Installation

- Avoid placing the unit in a location subject to:
 - mechanical vibration
 - high humidity
 - excessive dust
 - direct or excessive sunlight
 - extremely high or low temperatures
- Do not use other electronic equipment near the unit. The unit will not work properly in strong electromagnetic fields.
- Do not place a heavy object such as a monitor on the printer.

Condensation

- If the printer is subject to wide or sudden changes in temperature, such as when it is moved from a cold room to a warm room or when it is left in a room with a heater that tends to produce large amounts of moisture, condensation may form inside the printer. In such cases the printer will probably not work properly,

and may even develop a fault if you persist in using it. If condensation forms, turn off the power and leave the printer to stand for at least one hour.

- If the printing pack is subjected to wide or sudden changes in temperature, condensation may form on the ink ribbon or paper. This will cause the printer to malfunction. Also, if the printing pack is used in this state, spots are likely to appear on the printout. Therefore, avoid storing the printing pack in locations subject to wide or sudden changes of temperature.
- To store a half-used printing pack, replace it in its original packing and reseal the package. If possible, keep the sealed printing pack in a cool, dark location. To subsequently use the printing pack, place it, in its sealed package, in a warm room for several hours. Doing so prevents condensation from forming when the printing pack is removed from its package.

Location

To prevent internal heat built-up, leave enough room around the printer for air to circulate through the vents on the left hand side and top of the cabinet.

Before Transporting the Printer

Before transporting the printer, remove ink ribbon cartridge and paper tray and then put them back into their original packing. Transporting the printer with the supplied accessories still installed may cause malfunctions.

Cleaning

Note

Be sure to turn off the power of the printer and disconnect the AC power cord from the wall outlet before cleaning.

Cleaning the cabinet

Clean the cabinet, panel and controls with a soft dry cloth, or a soft cloth lightly moistened with a mild detergent solution. Do not use any type of solvent, such as alcohol or benzene, which may damage the finish.

Ink Ribbon and Paper

Both paper and an ink ribbon are necessary for printing. Use the ink ribbon with the paper contained in the same package.

UPC-55 Color Printing Pack

Contains color ink ribbon cartridge and paper.
Color ink ribbon for 100 sheets, 2 rolls
Paper, 1 package (100 sheets) ×2

Note

If the paper has been exhausted, replace the ink ribbon together with the paper.

Specifications

Power requirements

100 to 120 V AC, 50/60 Hz
(for 100 to 120 V AC users)

220 to 240 V AC, 50/60 Hz
(for 220 to 240 V AC users)

Input Current 2.8 A max. at 25°C
(for 100 to 120 V AC users)

1.2 A max. at 25°C
(for 220 to 240 V AC users)

Operating temperature

5°C to 35°C (41°F to 95°F)

Operating humidity

20% to 80% (no condensation allowed)

Storage and transport temperature

-20°C to 60°C (-4°F to 140°F)

Storage and transport humidity

20% to 90% (no condensation allowed)

Dimensions Approx. 280 × 125 × 398 mm (w/h/d)
(11 1/8 × 5 × 15 3/4 inches)

Mass Approx. 9 kg (19 lb 13 oz)

Printing system

Sublimation heat transfer printing

Printable pixels

When printing the full-image: 2528 × 1920 dots

Total gradation 256 levels each for yellow, magenta, and cyan

Printing time When the printer is set to high speed: Approximately 20 seconds

Thermal head 14.93 dots/mm

ψ (USB) connector

Universal Serial Bus (USB)
Specification Revision 2.0

Input connector

AC IN (for power input)

Supplied accessories

Paper tray (1)
USB connecting cable (1)
Ink ribbon holder (1)
Software License Agreement (1)
Before Using this Printer (1)
CD-ROM (including the printer drivers and PDF files of multi-lingual Instructions For Use) (1)

Optional accessories

UPC-55 Color Printing Pack

Medical Specifications

Protection against electric shock:
Class I

Protection against harmful ingress of water:
Ordinary

Degree of safety in the presence of flammable anesthetics or oxygen:

Not suitable for use in the presence of flammable anesthetics or oxygen
Mode of operation:
Continuous

Design and specifications are subject to change without notice.

Troubleshooting

The following troubleshooting checks will help you correct the most common problems you may encounter with your unit. Before proceeding with these trouble checks, first check that the power cord is firmly connected. Should the problem persist after you have applied the remedy, unplug the unit and contact your Sony dealer or local authorized Sony service facility.

| Symptoms | Possible causes and remedies |
|--|---|
| The printer does not print, even if the command is sent from the computer. | <ul style="list-style-type: none">The POWER switch of the printer is not set to ON. →Set the POWER switch of the printer to ON.Connections may not be correct. →Check connections and rectify, if necessary. (See page 7.) |
| The printer does not print. | The problem is indicated by the indicators on the ribbon door. →See “Indicators on the Ribbon Door” on page 18. |
| The printout color is very pale. | The paper is not loaded correctly. →Check which side of the paper is the printing side, then load the paper again. (See page 12.) |
| The ink ribbon cannot be set. | You may be trying to load an ink ribbon that can not be used with this printer has been loaded. →Load the appropriate ink ribbon. (See page 16.) |
| The ink ribbon cartridge cannot be loaded. | <ul style="list-style-type: none">The thermal head has moved out of position. →Close the ribbon door, and turn the power off, then back on again. The thermal head moves so that you can now install the ink ribbon cartridge. (See page 9.)The ink ribbon is not loaded correctly. →Load the ink ribbon correctly. See “Loading an Ink Ribbon Cartridge” on page 9. |
| The blank paper is ejected and the RIBBON indicator lights. | The ink ribbon has been exhausted. Do not reuse the ejected blank paper. →Replace the ink ribbon. (See page 9.) Do not reuse the ejected paper. Discard that paper. |

Indicators on the Ribbon Door

If a problem occurs, the indicators on the ribbon door such as PRINT, ALARM, RIBBON and/or PAPER light or blink to indicate the problem condition. The following table shows the relation between lighting or blinking condition of each indicator and possible cause and remedies.

| Indicators | | Possible cause and remedies |
|------------|--|---|
| Lighting | Blinking | |
| PRINT | | Printing |
| | PRINT | Data receiving |
| | PRINT (In this case, it blinks slowly.) | The thermal head is being heated so that the printer is ready to start. |
| RIBBON | | <ul style="list-style-type: none"> The ink ribbon has been exhausted. → Replace the old one with a new ink ribbon. (See page 9.) (The ink ribbon cannot be reused.) In this case, if the white paper is ejected. Discard this paper. The ink ribbon has torn. → Repair the torn ink ribbon. (See page 11.) |
| PAPER | | <ul style="list-style-type: none"> Paper has been exhausted. → Load the paper. (See page 12.) Also, replace the ink ribbon. The paper tray is not installed. → Install the paper tray. (See page 13.) |
| ALARM | | <ul style="list-style-type: none"> The ribbon door is open. → Close the ribbon door surely. Paper has jammed inside the printer. → Remove any jammed paper from the printer. (See page 19.) The maximum number of printouts has accumulated on the paper tray. → Remove the printouts. Printing starts again. (See page 14.) |
| | ALARM | The printer is recovering from an error. → Wait for a while until the printer is ready. |

| Indicators | | Possible cause and remedies |
|---|----------|---|
| Lighting | Blinking | |
| All of indicators, PRINT, RIBBON, PAPER and ALARM | | A problem requiring a service call has occurred. → You cannot use the printer any more. Turn off the power of the printer first. Then contact your Sony service facility or your nearest dealer to fix the problem and clear the error indicators. |

If the Paper Jams

If the ALARM indicator lights on the ribbon door, or the message “Paper jam. Printing is aborted. Please remove the jammed paper and print again.” or “Motor or sensor trouble. Printing is aborted after you press the PRINT button and during printing. Please turn off the printer, then turn it back on and print again.” appears on a monitor of a computer during printing after you press the PRINT button, the paper may have jammed inside the printer.

Remove the jammed paper according to the process described below.

- 1 Push in the paper tray to remove it.
If any printouts have been ejected onto the paper tray and have accumulated on the paper tray, remove them before removing the paper tray.

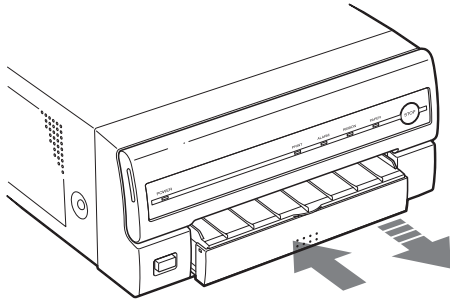

- 2 Check whether any paper is jammed inside the printer. If you find a jammed sheet, slowly pull it straight out.

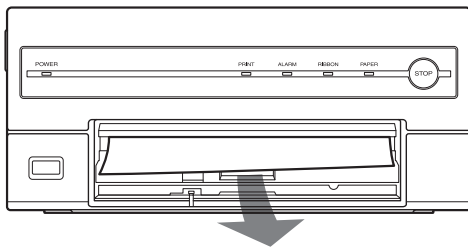

If you cannot remove the jammed paper even if you perform the operation in step 2, remove the jammed paper according to instructions described in the following “If you can not remove the jammed paper yet”.

- 3 Load the paper into the paper tray correctly.

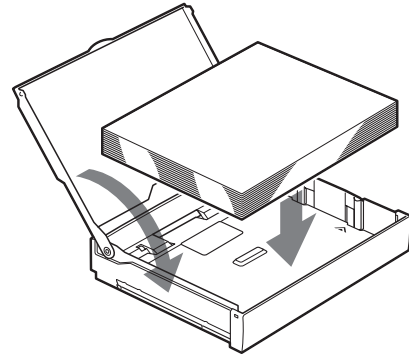

Notes

- Do not reuse the jammed paper. Discard that paper.
- Use only paper recommended in this manual.

- 4 Re-insert the removed paper tray.

If you can not remove the jammed paper yet

Precautions

- Turn the printer power off and remove the power cable from the printer.
- When you turn the printer over, remove any connecting cables. If cables are broken or bent, this may cause fire or electrical shock.
- When you remove the jammed paper, be careful not to injure your fingers when touching the parts inside the printer.

- 1 Be sure to set the power switch of the printer to off and remove the power cable and other connecting cables.
- 2 Remove the ink ribbon cartridge and the paper tray from the printer.
- 3 Turn the printer over.

- 4** Remove the one screw with which the back cover plate is secured, using a coin.

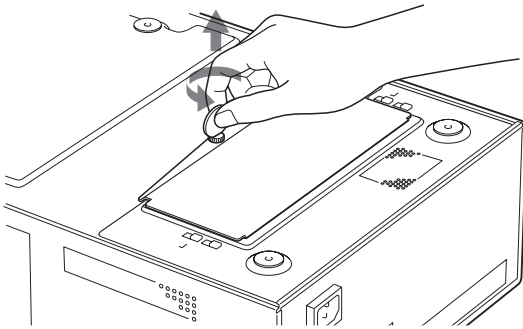

- 5** Pull the back cover plate up and remove it from the printer.

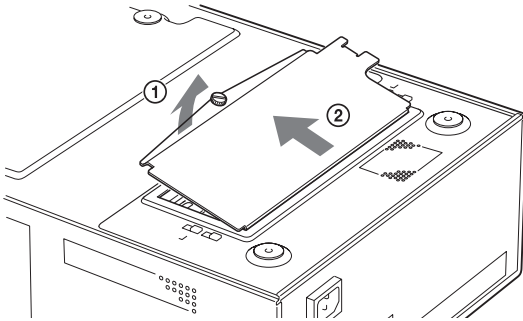

- 6** Remove the jammed paper slowly.

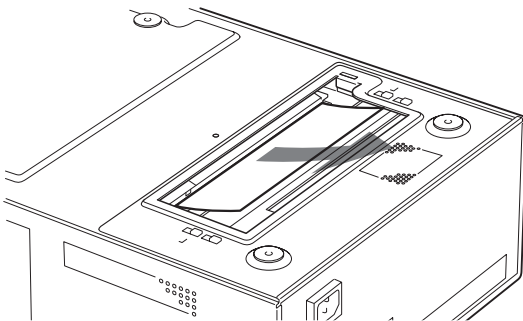

- 7** Replace the back cover plate.

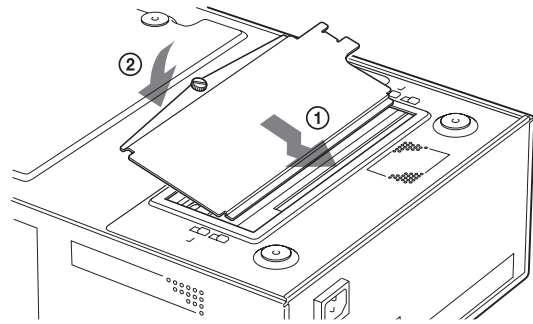

Note

When you put it back, be careful not to catch your fingers or any other object in the back cover plate.

- 8** Secure the back cover plate using the screws removed in step 4.

Confirm that the screw holes of the back side of the printer and the back cover plate match before securing them.

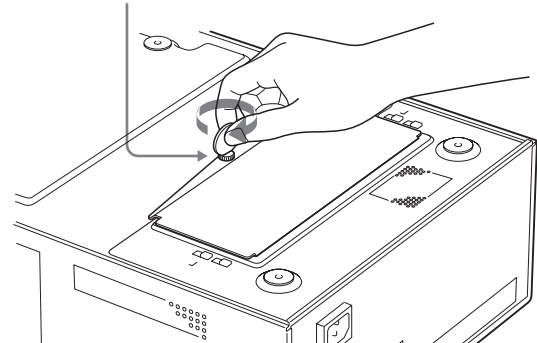

When using the printer again

Confirm the following before using the printer again.

- Confirm that connecting cables and the AC power cord are securely connected.
- Reset the paper tray in the printer.

If you still cannot remove the paper

Do not try to remove it forcibly. Contact your nearest Sony dealer.

Index

A

- Accessories
 - paper tray 6
 - USB connecting cable 6
- Alarm
 - indicating the problem using the indicators 18
 - indicators on the ribbon door 18

C

- Cleaning
 - cabinet 15
- Connections 7

G

- Getting Started 5

I

- Ink ribbon
 - handling 11
 - notes on storing 11
- Ink ribbon cartridge
 - if you cannot remove 9
 - loading 9
 - removing 9

L

- Location and function of parts and controls
 - front panel 5
 - rear panel 6

O

- Operation 9

P

- Paper
 - notes on storing 13
- Paper jams 19
- Paper tray
 - inserting 13
- Precaution
 - before transporting the printer 15
 - condensation 15
 - installation 15
 - safety 15
- Printer driver
 - installing 7
- Printing 13

- Printing pack
 - available printing pack 16

S

- Specifications 16
- System configuration 5
- System overview 5

T

- Troubleshooting 17

U

- USB 2.0 7
- USB port connection 7

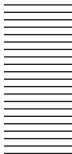

Sony Corporation

<http://www.sony.net/>

Free Manuals Download Website

<http://myh66.com>

<http://usermanuals.us>

<http://www.somanuals.com>

<http://www.4manuals.cc>

<http://www.manual-lib.com>

<http://www.404manual.com>

<http://www.luxmanual.com>

<http://aubethermostatmanual.com>

Golf course search by state

<http://golfingnear.com>

Email search by domain

<http://emailbydomain.com>

Auto manuals search

<http://auto.somanuals.com>

TV manuals search

<http://tv.somanuals.com>