

**Instruction Manual**  
**3270 • 3271 • 3272 • 3279 • 3280 • 3282**  
**Laminate Trimmers**

## Getting the most out of your tool.

Please take time to read this manual and pay particular attention to the safety rules we've provided for your protection. Don't forget to send in your owner's registration card. If you have any questions about your tool please call:

**1-800-9-BD TOOL**  
**(1-800-923-8665)**

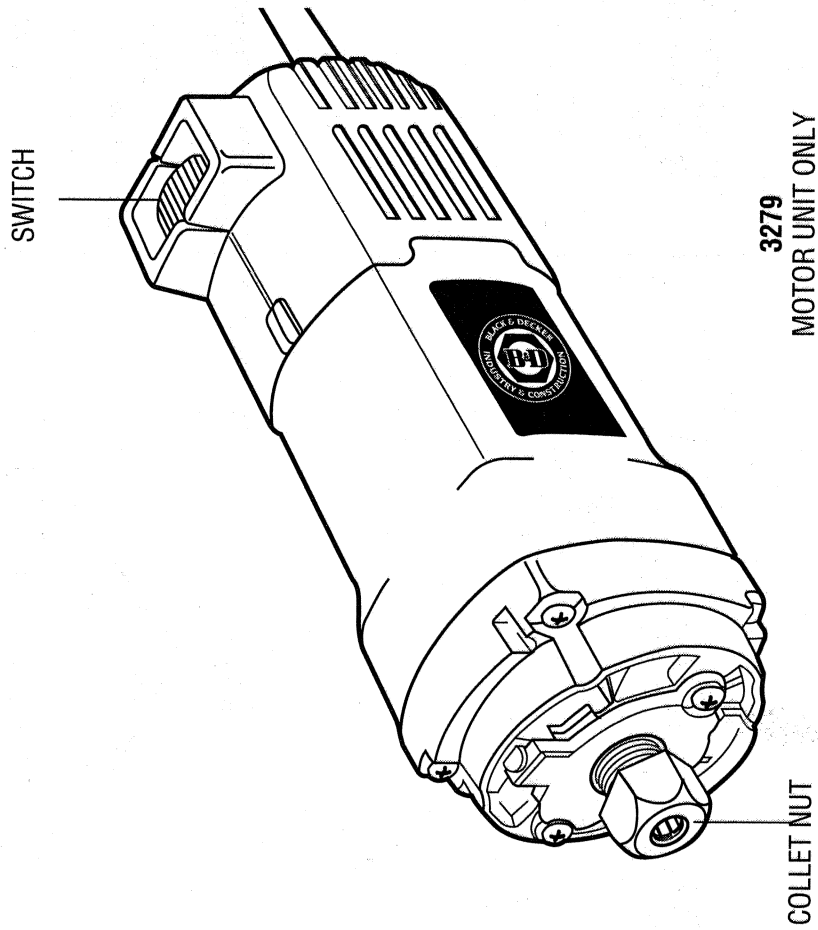

<p><b>3270</b> Motor Unit and Trim Base (3275) with Copy Follower</p>	<p><b>3271</b> Motor Unit and Tilting Base (3276) with Copy Follower</p>	<p><b>3272</b> Motor Unit and Offset Base (3277)</p>	<p><b>3280</b> Motor Unit with: Trim Base (3275) Offset Base (3277) Tilting Base (3276) Seaming Base (3278) 5" Round Base (3273)</p>	<p><b>3282</b> Motor Unit and Seaming Base (3278)</p>
---	--	--	--	---

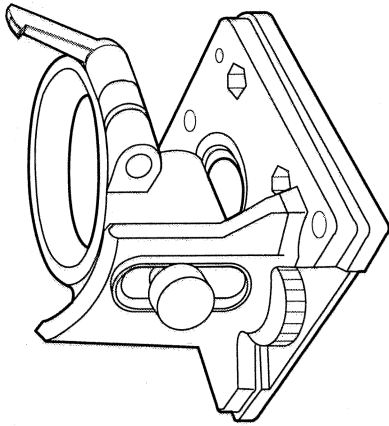

**Trim Base  
(3275)**

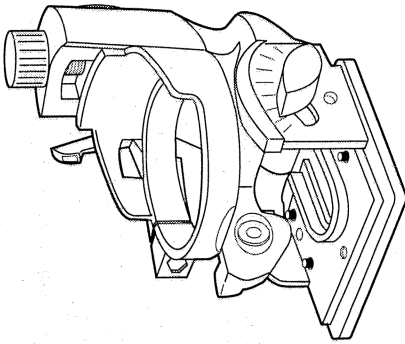

**Tilting Base  
(3276)**

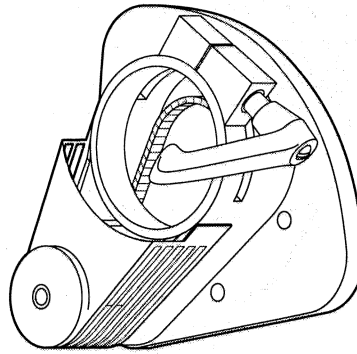

**Offset Base  
(3277)**

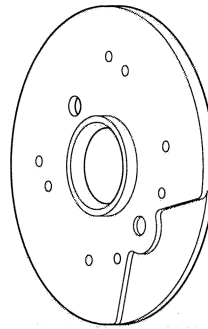

**Round Base  
(3273)**

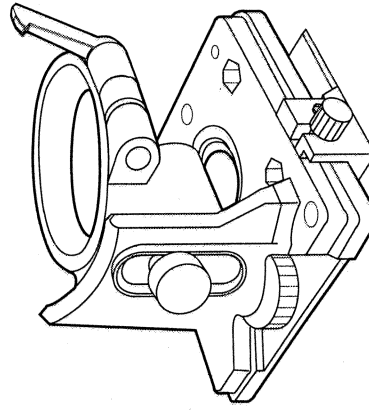

**Seaming Base  
(3278)**

## FOR YOUR SAFETY - ALL TOOLS

**WARNING:** When using electric tools, basic safety precautions should always be followed to reduce risk of fire, electric shock, and personal injury, including the following:

### READ ALL INSTRUCTIONS.

1. **KEEP WORK AREA CLEAN.** Cluttered areas and benches invite injuries.
2. **CONSIDER WORK AREA ENVIRONMENT.** Don't expose power tools to rain. Don't use power tools in damp or wet locations. Keep work area well lit.
3. **GUARD AGAINST ELECTRIC SHOCK.** Prevent body contact with grounded surfaces. For example; pipes, radiators, ranges, refrigerator enclosures.
4. **KEEP CHILDREN AWAY.** All visitors should be kept away from work area. Do not let visitors contact tool.
5. **STORE IDLE TOOLS.** When not in use, tools should be stored in dry, and high or locked-up place – out of reach of children.
6. **DON'T FORCE TOOL.** It will do the job better and safer at the rate for which it was intended.
7. **USE RIGHT TOOL.** Don't force small tool or attachment to do the job of a heavy-duty tool. Don't use tool for purpose not intended, for example, don't use circular saw for cutting tree limbs or logs.
8. **DRESS PROPERLY.** Do not wear loose clothing or jewelry. They can be caught in moving parts. Non-skid footwear is recommended when working outdoors. Wear protective hair covering to contain long hair.
9. **USE SAFETY GLASSES.** Also use face or dustmask if operation is dusty.
10. **DON'T ABUSE CORD.** Never carry tool by cord or yank it to disconnect from receptacle. Keep cord from heat, oil, and sharp edges.
11. **SECURE WORK.** Use clamps or a vise to hold work. It's safer than using your hand and it frees both hands to operate tool.
12. **DON'T OVERREACH.** Keep proper footing and balance at all times.
13. **MAINTAIN TOOLS WITH CARE.** Keep tools sharp and clean for better and

safe performance. Follow instructions for lubricating and changing accessories. Keep handles dry, clean, and free from oil and grease.

14. **DISCONNECT TOOLS** when not in use, before servicing, and when changing accessories.
15. **REMOVE ADJUSTING KEYS AND WRENCHES.** Form habit of checking to see that keys and adjusting wrenches are removed from tool before turning it on.
16. **AVOID UNINTENTIONAL STARTING.** Don't carry plugged in tool with finger on switch. Be sure switch is off when plugging in.
17. **OUTDOOR USE EXTENSION CORDS.** When tool is used outdoors, use only extension cords intended for use outdoors and so marked.
18. **STAY ALERT.** Watch what you are doing. Use common sense. Do not operate tool when you are tired.
19. **CHECK DAMAGED PARTS.** Before further use of the tool, a guard or other part that is damaged should be carefully checked to determine that it will operate properly and perform its intended function. Check for alignment of moving parts, binding of moving parts, breakage of parts, mounting, and any other conditions that may affect its operation. A guard or other part that is damaged should be properly repaired by an authorized service center unless otherwise indicated in this manual. Have defective switches replaced by authorized service center. Don't use tool if switch does not turn it on and off.
20. **DO NOT OPERATE** portable electric tools near flammable liquids or in gaseous or explosive atmospheres. Motors in these tools normally spark, and the sparks might ignite fumes.
21. **CAUTION:** When drilling into walls, floors or wherever live electrical wires may be encountered, **DO NOT TOUCH THE CHUCK OR ANY FRONT METAL PARTS OF THE DRILL!** Hold the drill only by the plastic handle to prevent shock if you drill into a live wire.

**SAVE THESE INSTRUCTIONS FOR FUTURE USE**

# ADDITIONAL SAFETY INSTRUCTIONS

1. **DISCONNECT PLUG FROM POWER SUPPLY** before making adjustments or changing bits.
2. **ALWAYS WEAR EYE PROTECTION.**
3. **MAKE SURE** that the work piece is properly secured.
4. **KEEP CORD AWAY FROM CUTTING AREA** so that it will not get caught or hung up in the work.
5. **MAKE SURE** trimmer bit is clear of work piece before turning unit on.
6. **KEEP HANDS AWAY** from cutter when tool is running to prevent personal injury.
7. **HOLD TOOL FIRMLY** to prevent loss of control which could cause personal injury.
8. **BE SURE** motor has come to a complete stop before setting tool down between operations.
9. **DO NOT** touch trimmer bits after use- they may be extremely hot.
10. **NEVER** tighten collet nut without bit installed. This will cause damage to collet.
11. For use on wood and plastic only.
12. **ALWAYS** use chip guard while unit is on.
13. In the event the unit is not working properly, take unit to closest B&D certified service center for repair.
14. **ALWAYS** tighten base onto motor pack before use.

## SAVE THESE INSTRUCTIONS

## Double Insulation

Double insulated tools are constructed throughout with two separate layers of electrical insulation or one double thickness of insulation between you and the tool's electrical system.

Tools built with this insulation system are not intended to be grounded. As a result, your tool is equipped with a two prong plug which permits you to use extension cords without concern for maintaining a ground connection.

**NOTE:** Double insulation does not take the place of normal safety precautions when operating this tool. The insulation system is for added protection against injury resulting from a possible electrical insulation failure within the tool.

**CAUTION:** When servicing all tools, USE IDENTICAL REPLACEMENT PARTS. Repair or replace damaged cords.

## Polarized Plug

Polarized plugs (one blade is wider than the other) are used on equipment to reduce the risk of electric shock. When provided, this plug will fit in a polarized outlet only one way. If the plug does not fit fully into your outlet, reverse the plug. If it still does not fit, contact a qualified electrician to install a proper polarized outlet. Do not modify or change this plug in any way.

## Extension Cords

Make sure your extension cord is in good condition. When using an extension cord, be sure to use one heavy enough to carry the current your product will draw. An undersized cord will cause a drop in line voltage resulting in loss of power and overheating. Table 1 shows the correct size to use depending on cord length and nameplate ampere rating. If in doubt, use the next heavier gage. The smaller the gage number, the heavier the cord.

**Table 1**

Minimum Gage for Cord Sets

Volts	Total Length of Cord in Feet		
120V	0-25	51-100	101-150
240V	0-50	51-100	101-200 201-300

**Ampere Rating**

More Than American Wire Gage

More Than	18	16	16	14
0 - 6				
6 - 10	18	16	14	12
10 - 12	16	16	14	12
12 - 16	14	12	Not Recommended	

**Motor**

Be sure your power supply agrees with nameplate marking.

120 AC means your tool may be operated only with alternating current and never with direct current.

Voltage decrease of more than 10% will cause loss of power and overheating. All tools are factory tested; if this tool does not operate, check the power supply.

**Switch**

To start the motor, slide the switch to on position. To stop the motor, slide the switch to off position. (See FIGURE 1)

**Installing and Removing the Bit**

(For units with trim base, tilting base, seaming base, or 5" round base)

**NOTE:** Bits must be installed with the motor unit removed from base.

TURN OFF TOOL AND DISCONNECT FROM POWER SUPPLY BEFORE INSTALLING OR REMOVING BIT.

1. To install bit, insert shank of bit into collet as far as it will go and then withdraw bit approximately 1/16".
2. Depress spindle lock and rotate collet nut clockwise until lock engages hole in motor spindle. (See FIGURE 2)
3. With spindle lock engaged, tighten collet nut securely by turning clockwise using wrench provided.
4. To remove bit, depress spindle lock and rotate collet nut counterclockwise until lock engages hole in motor spindle.
5. While holding spindle lock engaged, loosen collet nut by turning counterclockwise with wrench provided.
6. If bit does not remove with ease, tap the collet nut with a wrench to release the bit.

**FIGURE 1**

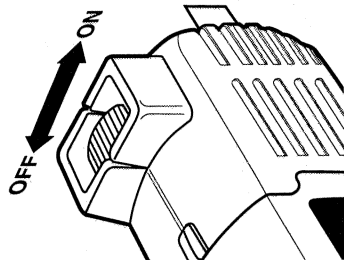

**FIGURE 2**

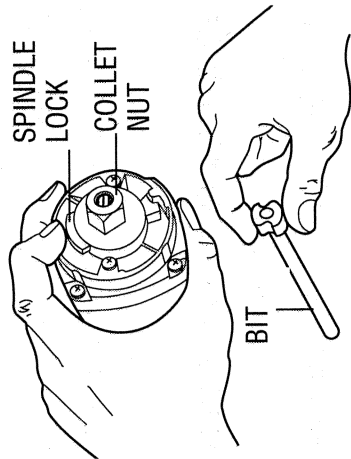

## Motor Units with Trim Base

*To assemble trim base to the motor unit*

TURN OFF TOOL AND DISCONNECT FROM POWER SUPPLY.

1. Loosen base by turning base locking arm counterclockwise. (See FIGURE 3)
2. Place motor unit onto base. (Motor unit can rotate 360° inside of base)
3. Tighten motor unit to base by turning locking arm clockwise.

### To Adjust Depth of Cut

TURN OFF TOOL AND DISCONNECT FROM POWER SUPPLY.

1. Loosen the base locking knob. (See FIGURE 3)
2. Turn depth adjustment wheel counterclockwise to raise the base and increase the depth of cut.
3. Turn depth adjustment wheel clockwise to lower base and decrease the depth of cut.
4. Tighten base locking knob.
5. Make a test cut in scrap material to check adjustment. Repeat the above steps until the desired depth of cut is achieved.

### Installing Template Guides

TURN OFF TOOL AND DISCONNECT FROM POWER SUPPLY.

1. Remove the trim base from motor unit by loosening base locking arm.
2. Install the desired template guide (not included) in recess of sub-base and secure with template guide nut.
3. Reassemble the base onto the motor unit by tightening base locking arm.

**FIGURE 3**

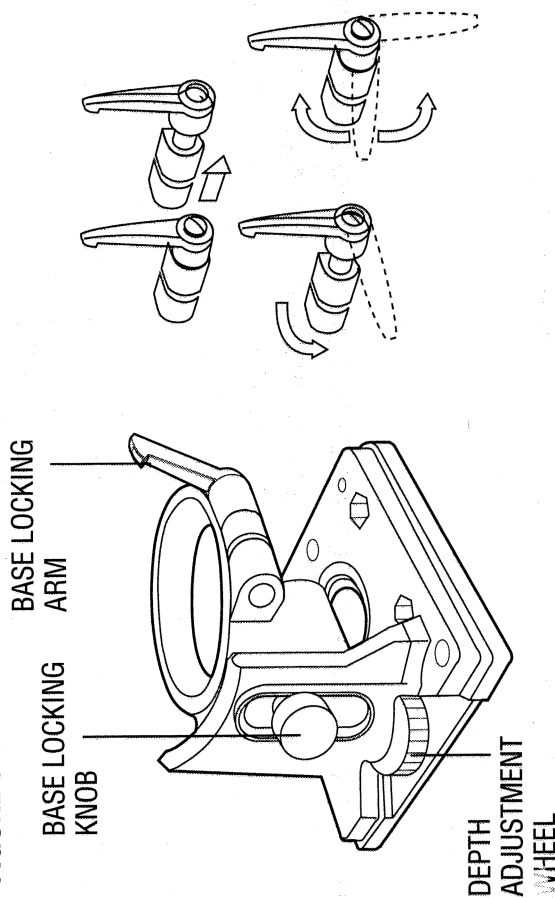

## Self Piloted or Ball Bearing Bits

ALWAYS DISCONNECT TOOL FROM POWER SUPPLY BEFORE INSTALLING BITS OR MAKING ADJUSTMENTS.

Self-piloted bits include a surface below the cutter which rides against the work and guides the bit. Pilots may take the form of an integral round tip or a ball bearing.

Additional trim guides are not required when using self-piloted bits. Self-piloted bits can be used with all types of trimmer bases.

## Copy Follower (for use with trim and tilt bases)

Trimming bits without a pilot require a copy follower:

1. Mount copy follower to unit using depth adjustment knob. (See FIGURE 5)
2. Adjust depth of cut by loosening or tightening depth adjustment knob.
3. Adjust the horizontal guide by loosening the lock knob on the bottom of the guide and turning the horizontal adjustment knob. Tighten the locking knob on the bottom of the guide.
4. Make a trial cut with the guide against the work piece to check the alignment and readjust if necessary.

### DW670, DW671, DW673:

Includes ball bearing guide (pictured) and a plate guide. In order to use the plate guide, it should be snapped onto the ball bearing. This unit also comes complete with solid surface skis that can be attached with screws to the bottom of trim sub-base.

## MOTOR UNIT WITH COPY FOLLOWER

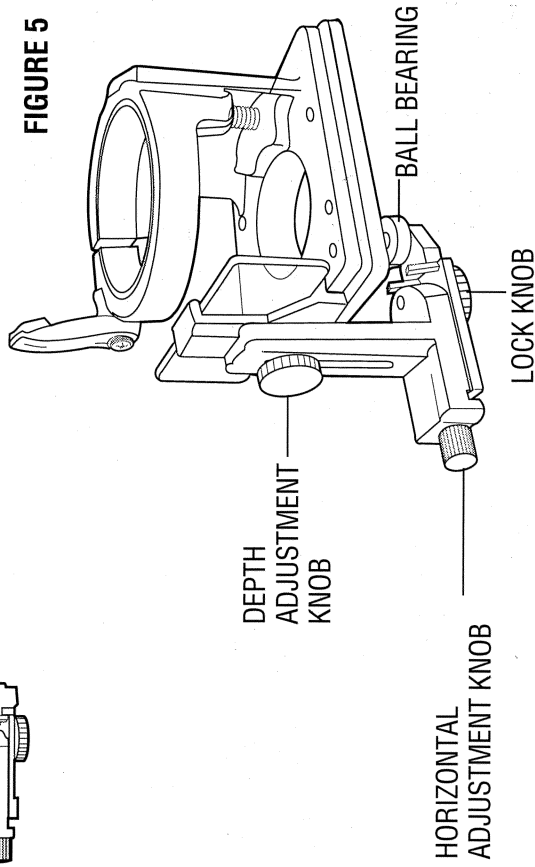
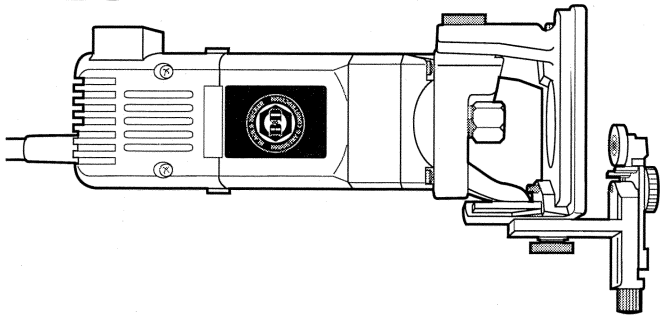



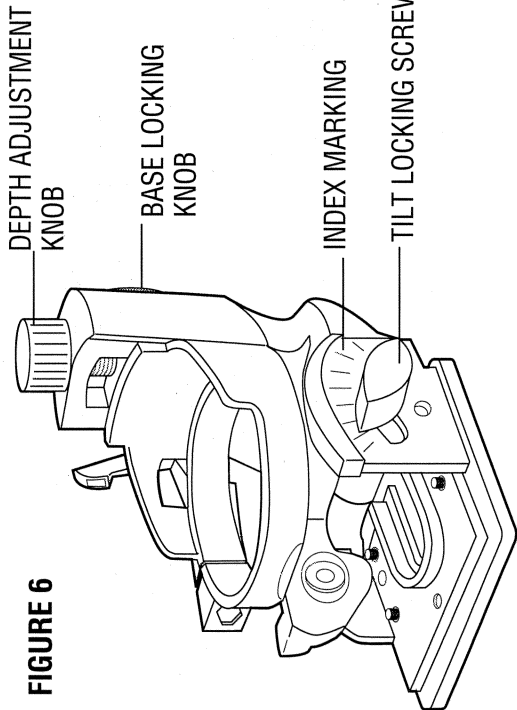

**FIGURE 6**

## Motor Unit With Tilting Base

When edge trimming plastic laminate, always use self-piloted laminate trimming bits. Insert bits as described on page 4.

### To assemble tilt base to the motor unit:

TURN OFF TOOL AND DISCONNECT FROM POWER SUPPLY.

1. Loosen base by turning base locking arm counterclockwise. (See FIGURE 6)
2. Place motor unit into base. (Motor unit can rotate 360° inside of base)
3. Tighten motor unit to base by turning locking arm clockwise.

### To Adjust Depth of Cut

TURN OFF TOOL AND DISCONNECT FROM POWER SUPPLY.

1. Loosen the base locking knob (See FIGURE 6)
2. Turn depth adjustment knob counterclockwise to raise the base and increase the depth of cut.
3. Turn depth adjustment knob clockwise to lower base and decrease the depth of cut.
4. Tighten base locking knob.
5. Make a test cut in scrap material to check adjustment. Repeat the above steps until the desired depth of cut is achieved.

### To Adjust Angle of Cut

TURN OFF TOOL AND DISCONNECT FROM POWER SUPPLY.

Tilting Base units have an angular adjustment of 90° (45° in either direction).

1. (See FIGURE 6) Loosen the two tilt locking screws which hold the tilt base in position and adjust to the desired angle using index marking.
2. Tighten the screws to hold the setting.
3. Make a trial cut on scrap material and readjust if necessary.

**FIGURE 8**

Trims odd angled corners less than or greater than 90°

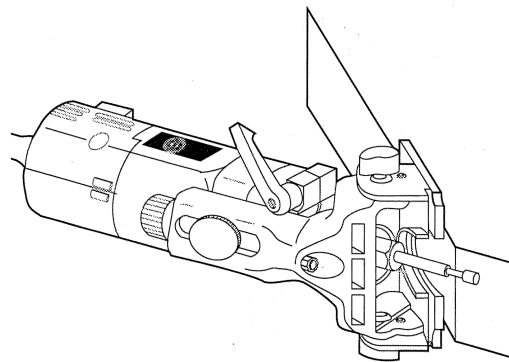

**FIGURE 7**

Trims up to vertical surfaces

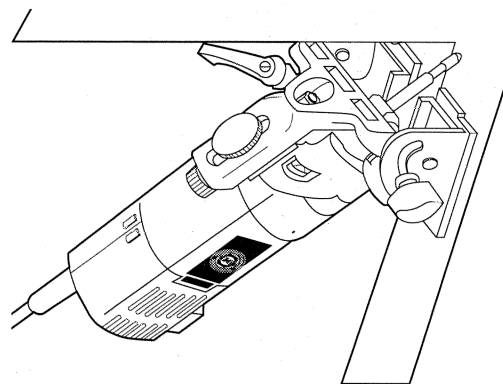

## Motor Unit With Offset Base

*To assemble offset base to motor unit:*

TURN OFF TOOL AND DISCONNECT FROM POWER SUPPLY.

1. Remove collet nut and collet from motor unit. (See FIGURE 9)
2. Assemble drive pulley to motor spindle and tighten securely.
3. Install motor unit into base, making sure that the drive pulley engages drive belt in offset base. (FIGURE 10)  
**(NOTE:** A screwdriver may be inserted through slot in base to aid in aligning drive belt onto pulley. See FIGURE 11)
4. Secure base to motor with locking arm.

## Installing and Removing Bit

TURN OFF TOOL AND DISCONNECT FROM POWER SUPPLY.

See FIGURE 12

1. Insert long portion of hex wrench through spindle lock hole.
2. Insert bit into collet.
3. Place wrench on collet nut and tighten hex wrench.
4. To remove bit, reverse above procedure. If bit does not remove easily, tap the bit shank with wrench to release bit.

**CAUTION:** NEVER TIGHTEN COLLET WITHOUT BIT INSTALLED.

FIGURE 9

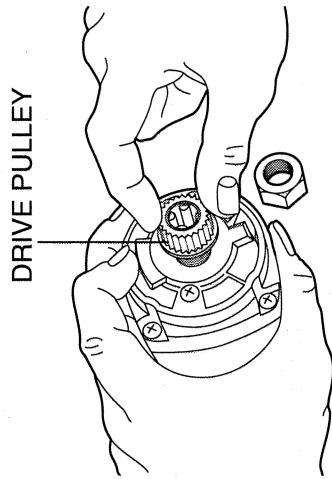

FIGURE 10

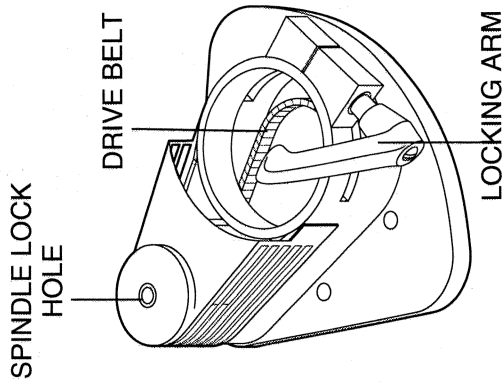

FIGURE 11

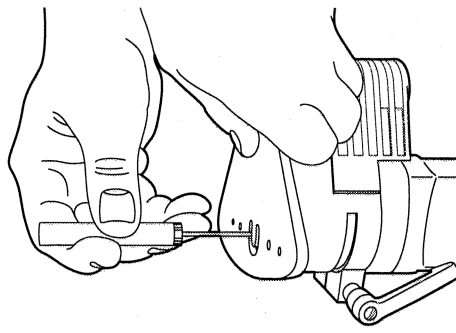
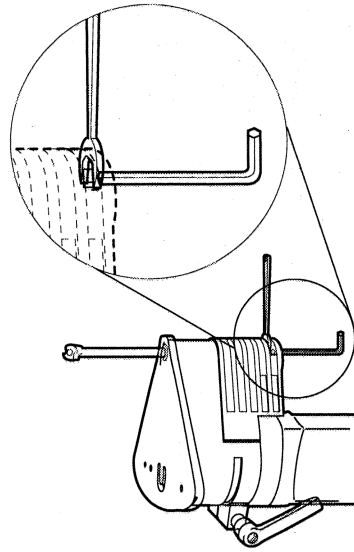
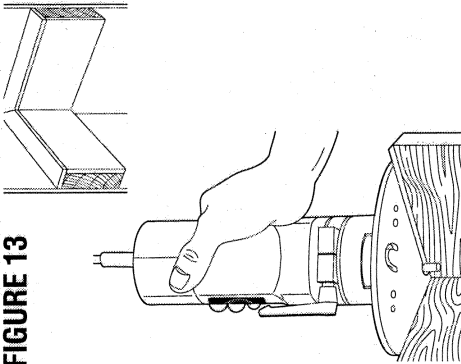

FIGURE 12



**FIGURE 13**



**FIGURE 13**

Trimming into and out of installed backslash corner with little or no hand trimming required. Will trim into and out of 90° corners with ease using self-piloted bit.

**FIGURE 14**

Trimming 3/4" vertical backslash. Self-piloted bit guides trimmer for exact cut.

**FIGURE 15**

Accurately scribing the back side of a preassembled panel or post formed backslash. Once the lip is accurately scribed, the trimmed portion is then pushed against the wall and mated exactly.

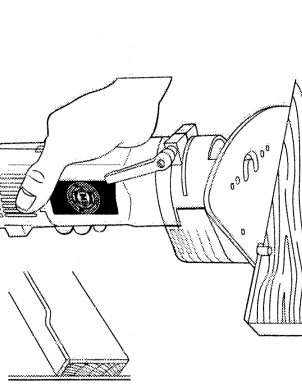

**FIGURE 14**

**FIGURE 15**

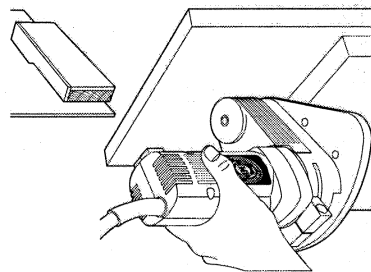

### **Motor Unit With Seaming Base**

The seaming base is designed to cut plastic laminates when creating joints between two adjoining pieces of laminate. Properly adjusted, the router will produce accurate seams between adjacent sections of the laminated surface.

Insert the bit as described on page 4.

#### **To assemble seaming base to the motor unit:**

TURN OFF TOOL AND DISCONNECT FROM POWER SUPPLY.

1. Loosen base by turning base locking arm counterclockwise.
2. Place motor unit onto base. (Motor unit can rotate 360° inside of base)
3. Tighten motor unit to base by turning locking arm clockwise.

#### **To Adjust Depth of Cut**

TURN OFF TOOL AND DISCONNECT FROM POWER SUPPLY.

1. Loosen the base locking knob (See FIGURE 17)
2. Turn depth adjustment wheel counterclockwise to raise the base and

- increase the depth of cut.
3. Turn depth adjustment wheel clockwise to lower base and decrease the depth of cut.
  4. Tighten base locking knob.
  5. Make a test cut in scrap material to check adjustment. Repeat the above steps until the desired depth of cut is achieved.

#### ***For Horizontal Adjustment***

**TURN OFF TOOL AND DISCONNECT FROM POWER SUPPLY.**

1. Turn knob on side of base counterclockwise to loosen seaming attachment.
2. Move horizontal seaming attachment knobs to create tight or loose joints as desired.
3. Turn knob on side of base clockwise to tighten seaming attachment.
4. It is advisable to make sample cuts on scrap material to determine if further adjustment is required before beginning work.

To create a joint, contact cement should be applied to the core material and a fixed piece of laminate. A second piece of laminate should be fastened to the core and overlap the fixed piece by about 1/2". The second piece of laminate will then pass over the aluminum plate and be cut to the proper length by the router bit.

It is necessary to keep the laminate pressed down tightly near the seam to keep chips from getting into the joint. It is also important to keep steady pressure on the tool so that the guiding edge of the base remains in contact with the fixed piece.

#### **MOTOR UNIT WITH SEAMING BASE**

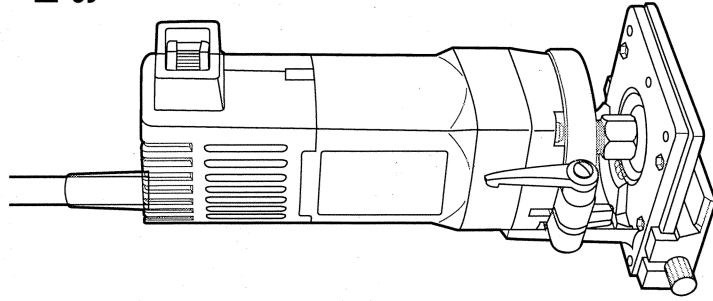

**FIGURE 17**

BASE LOCKING  
KNOB

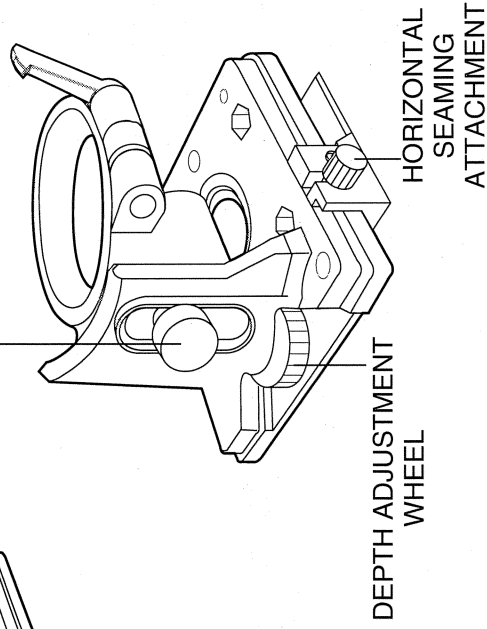

DEPTH ADJUSTMENT  
WHEEL

HORIZONTAL  
SEAMING  
ATTACHMENT

# YOUR POWER TOOLS MAY BE SERVICED AT THE FOLLOWING B&D SERVICE CENTERS.

<b>ALABAMA:</b>	Birmingham 36209, 2412 Green Springs Hwy. ....	205-942-0538	<b>IOWA:</b>	Des Moines 50310, 3427 Merle Hay Rd. ....	515-270-1340
	Mobile 36608, 3831 Airport Blvd. ....	205-343-6624	<b>KANSAS:</b>	Wichita 67213, 155 S. West St. ....	316-943-1271
<b>ALASKA:</b>	Anchorage 99518, 910 West International Airport Rd. ....	907-563-4664	<b>KENTUCKY:</b>	Louisville 40213, 5211 Preston Hwy. ....	502-968-7100
<b>ARIZONA:</b>	Mesa 85202, 535 S. Dobson, Suite 7. ....	602-461-1074	<b>LOUISIANA:</b>	Baton Rouge 70815, 11859 Florida Blvd. ....	504-272-8111
	Phoenix 85013, 4501 N. 7th Avenue. ....	602-279-6414		Harvey 70058, 2900 Lapalco Blvd. ....	504-366-8676
	Tucson 85712, 4845 E. Speedway Blvd. ....	602-323-3388		Melaine (New Orleans) 70002, 3504 N. Causeway Blvd. ....	504-837-2550
<b>ARKANSAS:</b>	Little Rock 72201, 519 W. Seventh St. ....	501-372-3040	<b>MARYLAND:</b>	Baltimore (East) 21205, 4712 Erdman Ave. ....	410-485-5550
<b>CALIFORNIA:</b>	Anaheim 92806, 540 South State College Blvd. ....	714-772-4050		Baltimore (North) 21130, 29-31 Cranbrook Rd., Cockeysville. ....	410-666-5966
	Concord 94520, 1500 Monument Blvd., #C2. ....	510-682-4860		Baltimore (South) 21122, 8220 Ritchie Hwy., Pasadena. ....	410-647-8456
	Fresno 93710, 5412 North Blackstone Ave. ....	209-435-0810		Colmar Manor 20722, 4153 Bladensburg Rd. ....	301-779-3808
	Long Beach 90805, 2011 South St. ....	310-422-5825	<b>MASSACHUSETTS:</b>	Brighton (Boston) 02135, 12 Market St. ....	617-782-6264
	Los Angeles 90040, 4820 South Eastern Ave., Suite "L". ....	213-720-1834		Seekonk 02771, 120 Highland Ave. ....	508-336-6510
	Riverside 92506, 6215 Magnolia Ave., Suite "B". ....	909-787-9700	<b>MICHIGAN:</b>	Grand Rapids 49512, 3040 28th St., S.E. ....	616-949-8931
	Sacramento 95825, 2033 Fulton Ave. ....	916-972-9090		Warren 48093, 27035 Van Dyke Blvd. ....	313-756-6711
	San Diego 92123, 9270 Claremont Mesa Blvd. ....	619-279-2011	<b>MINNESOTA:</b>	Westland (Detroit) 48185, 8067 North Wayne Rd. ....	313-427-1520
	San Jose 95128, 1185 So. Bascom Ave. ....	408-293-7350	<b>MISSOURI:</b>	Bloomington (Minneapolis-St. Paul) 55420, 9517 Lyndale Ave., S. ....	612-884-9191
	San Leandro 94578, 15206 E. 14th St. ....	510-276-1610		Kansas City 64111, 4324 Main St. ....	816-531-0629
	Van Nuys 91411, 14920 Victory Blvd. ....	818-787-5531		St. Ann (North St. Louis) 63074, 3637 North Lindbergh Blvd. ....	314-739-4661
<b>COLORADO:</b>	Denver 80219, 1171 S. Federal Blvd. ....	303-922-8325		St. Louis 63131, 12852 Manchester Rd. ....	314-821-8740
<b>CONNECTICUT:</b>	Orange 06477, 481 Boston Post Rd. ....	203-795-5983	<b>NEBRASKA:</b>	Omaha 68127, 4225 S. 84th St. ....	402-592-5666
	Weathersfield (Hartford) 06109, 662 Sias Dean Hwy. ....	203-563-8600	<b>NEVADA:</b>	Las Vegas 89104, 3411 East Charleston Blvd. ....	702-641-6555
<b>DISTRICT OF COLUMBIA:</b>	Washington		<b>NEW JERSEY:</b>	Cherry Hill 08034, 1444 E. Mariton Pike/Rte. 70. ....	609-429-2822
	Colimar Manor 20722, 4153 Bladensburg Rd. ....	301-779-3808		Little Falls 07424, RT 46 E. at Lower Notch Rd. ....	201-256-9373
	Falls Church, VA 22046, 344 W. Broad St. ....	703-533-7313	<b>NEW MEXICO:</b>	Union (Scotch Plains) 07076, 2520 Route #22 East. ....	908-233-5665
<b>FLORIDA:</b>	Ft. Lauderdale 33334, 799 E. Oakland Pk. Blvd. ....	305-566-5102	<b>NEW YORK:</b>	Albuquerque 87110, 5617 Menaul Blvd., N.E. ....	505-884-1002
	Jacksonville 32205, 920 Cassat Ave. ....	904-781-2253		Buffalo 14209, 881 W. Delavan Ave. ....	716-884-6220
	Miami (North) 33168, 13345 N.W. Seventh Ave. ....	305-681-6658		Canterech L.I. 11720, 2061-63 Middle Country Rd. ....	516-737-4706
	Miami (South) 33156, 12233 So. Dixie Hwy. ....	305-232-9497		Elmhurst (New York) 11373, 77-20 Queens Blvd. ....	718-335-1042
	Orlando 32803, 3807 E. Colonial Dr. ....	407-894-7011		Latham (Albany) 12110, 836 Troy-Schenectady Rd. ....	518-785-1867
	St. Petersburg 33709, 5635 49th St., N. ....	813-525-0273		Manhattan (New York) 10010, 50 West 23rd St. ....	212-929-6450
	Tampa 33609, 3432 W. Kennedy Blvd. ....	813-872-8317		Rochester 14623, 2969 W. Henrietta Rd. ....	716-424-1310
	West Palm Beach 33415, 310 South Military Trail. ....	407-689-3247		Syracuse 13214, 3485 Erie Blvd., East. ....	315-446-3086
<b>GEORGIA:</b>	Atlanta (South) 30349, 5330 Old National Hwy. ....	404-762-8844	<b>NORTH CAROLINA:</b>	Westbury L.I. (New York) 11590, 1061 Old Country Rd. ....	516-997-6140
	Smyrna 30080, 2550 Cobb Pkwy. ....	404-956-0869		Charlotte 28205, 3007 E. Independence Blvd. ....	704-374-1779
	Stone Mountain (Atlanta) 30086, 5723 Memorial Dr. ....	404-292-4714		Greensboro 27407, 3716 High Point Rd. ....	910-857-1300
<b>HAWAII:</b>	Honolulu 96819, 330 Sand Island Access Road. ....	808-847-7447	<b>OHIO:</b>	Raieigh 27604, 2930 Capital Blvd. ....	919-878-0357
<b>ILLINOIS:</b>	Des Plaines (Chicago) 60018, 1277 South Elmhurst Rd. ....	708-364-5220		Cincinnati 45241, 2310 E. Sharon Rd. ....	513-772-3111
	Lincolnwood (Chicago) 60646, 6710 N. Crawford Ave. ....	708-673-0923		Columbus 43227, 3975 E. Livingston Ave. ....	614-237-0461
	Lisle (West Chicago) 60532, 2950 Ogden Ave., Unit H. ....	708-717-1075			
	Moline 61285, 4433 23rd Ave. ....	309-762-3000			
	Oak Lawn (Chicago) 60453, 6343 W. 95th St. ....	708-423-7212			
<b>INDIANA:</b>	Evansville 47710, 307 First Ave., Crescent Cir. ....	812-425-4269			
	Hammond 46323, 7103 Kennedy Ave. ....	219-845-5100			
	Indianapolis 46224, 5999 Crawfordsville Rd. ....	317-243-8308			
<b>OHIO (CONTINUED):</b>	Dayton 45409, 2898 S. Dixie Dr. ....	513-298-1951			
	Mayfield Heights (East Cleveland) 44124, 5881 Mayfield Rd. ....	216-449-2770			
	Parma Heights (Cleveland) 44130, 6483 Pearl Rd. ....	216-942-9100			
	Toledo 43607, 3231 Dort St. ....	419-531-8921			
<b>OKLAHOMA:</b>	Oklahoma City 73106, 1318 Linwood Blvd. ....	405-232-7515			
	Tulsa 74145, 3120 S. Sheridan Rd. ....	918-622-5666			
<b>OREGON:</b>	Portland 97209, 1640 N.W. Johnson St. ....	503-228-8631			
<b>PENNSYLVANIA:</b>	Evans City 16033, 20808 Rt. 19 North. ....	412-779-9600			
	Harrisburg 17112, 6080 Allentown Blvd. ....	717-545-0651			
	Lancaster 17601, 118 Keller Ave. ....	717-393-5251			
	Philadelphia 19103, 333 N. 20th St. ....	215-564-5520			
	Philadelphia (North) 19115, 9977-81 Bustleton Ave. ....	215-464-7771			
	Pittsburgh 15232, 5437 Baum Blvd. ....	412-362-2700			
	Whitehall (Allentown) 18052, 2242 MacArthur Rd. ....	610-435-9544			
<b>PUERTO RICO:</b>	Puerto Nuevo. ....	809-783-3535			
<b>RHODE ISLAND:</b>	See Seekonk, MA				
<b>SOUTH CAROLINA:</b>	Greenville 29607, 1557 Laurens Rd. ....	803-232-3038			
<b>TENNESSEE:</b>	Knoxville 37917, 4118 N. Broadway. ....	615-688-0921			
	Memphis 38116, 1085 East Brooks Rd. ....	901-332-3444			
	Nashville 37211, 4811 Nolensville Rd. ....	615-833-8277			
<b>TEXAS:</b>	Amarillo 79106, 3008 West 6th Ave. ....	806-373-1531			
	Austin 78757, 6549 Burnet Rd. ....	512-459-1133			
	Dallas 75229, 2257 Royal Ln. ....	214-620-6655			
	El Paso 79915, 6822 Gateway East. ....	915-778-9769			
	Fort Worth 76111, 721 North Beach St. ....	817-831-3828			
	Houston 77022, 536 E. Tidwell Rd. ....	713-692-7111			
	Houston (S.W.) 77025, 9319 Stella Link Blvd. ....	713-664-3666			
	San Antonio 78201, 500 Culebra Ave. ....	210-732-1221			
<b>UTAH:</b>	Salt Lake City 84115, 1541 S. Third West St. ....	801-486-5828			
<b>VIRGINIA:</b>	Falls Church 22046, 344 W. Broad St. ....	703-533-7313			
	Norfolk 23513, 7631 Sewells Point Rd. ....	804-480-3333			
	Richmond 23222, 1424 Chamberlayne Ave. ....	804-649-9245			
<b>WASHINGTON:</b>	Seattle 98108, 421 S. Michigan St. ....	206-763-2010			
	Spokane 99208, N. 7011 Division St. ....	509-467-8190			
	Tacoma 98409, 2602 S. 38th St. ....	206-473-6040			
<b>WEST VIRGINIA:</b>	Charleston 25312, 1638 Sixth Ave. ....	304-943-0289			
<b>WISCONSIN:</b>	Milwaukee (Wauwatosa) 53226, 10424 West Bluemound Rd. ....	414-453-4240			

**YOUR POWER TOOLS MAY BE SERVICED AT THE FOLLOWING  
B&D SERVICE DEPOTS.**

**Alberta**  
Edmonton T5M1V1, 11440 142nd St. ....403-453-2373

**British Columbia**  
Vancouver V5M3A7, 1735 Houndry Rd .....604-281-9942

**Manitoba**  
Winnipeg R3H0K3, 834 St. James St. ....204-763-7291

**Nova Scotia**  
Halifax B3K2A4, 6100 Young St. ....902-453-5000

**Ontario**  
Brockville K6V5W6, 100 Colonial Ave. ....613-342-6641  
London N6L3A8, 901 Wellington Rd #6 .....519-649-2407  
Mississauga L4X1L3, 1480 Dundas St.E.#6 .....905-277-0011  
North York M3J3G5, 48 Kedliao Cros.....416-835-6740

**Québec**  
Montréal H1Y1B4, 3061 Boulanger .....614-722-1021

**FOR ADDITIONAL SERVICE LOCATIONS  
CALL: 1-800-9- BD TOOL**

**Accessories**

Recommended accessories for use with your tool are available at extra cost from your distributor or your local service center.

**CAUTION:** The use of any non-recommended accessory may be hazardous. If you need any assistance in locating any accessory, call 1-800-9-BD TOOL (1-800-923-8665) or contact Black & Decker, Consumer Services Department, P.O. Box 618, 626 Hanover Pike, Hampstead, MD 21074.

**Important**

To assure product safety and reliability, repairs, maintenance, and adjustments should be performed by B&D service centers or other qualified service organizations, always using B&D replacement parts.

Every B&D tool is of the highest quality.

If you wish to contact us regarding this product, please call toll free between 8:00am and 8:00pm ET, seven days a week:

**1-800-9-BD TOOL**  
(1-800-923-8665)

### **One Year Free Maintenance**

All B&D tools for Industry and Construction are covered under a one year free maintenance where B&D will inspect your tool for safety and provide necessary maintenance or repairs, including normal wear and tear parts, for one year, FREE OF CHARGE.

### **Full Warranty**

All B&D tools for Industry and Construction are warranted to be free of any defects in materials or workmanship. Upon thorough examination of tool, B&D will repair or replace, at our option, any product that is determined to be defective.

### **Conditions**

The service/safety check and the warranty do not apply to: repairs made or attempted by anyone other than an authorized B&D service location; misuse, abuse, neglect, improper application of the tool; missing parts; or normal wear and tear (after first year of ownership). Please return the complete unit, transportation prepaid, to any B&D factory owned or B&D authorized service center location (list provided with tool or see Yellow Pages under "Tools Electric").

---

**Black & Decker (U.S.) Inc. • 701 East Joppa Road, Towson, Maryland 21286**

**Printed in Italy. (JUN94-CD-1) Form No. 159386 Copyright © 1994 P.N. 947980-00**



## Free Manuals Download Website

<http://myh66.com>

<http://usermanuals.us>

<http://www.somanuals.com>

<http://www.4manuals.cc>

<http://www.manual-lib.com>

<http://www.404manual.com>

<http://www.luxmanual.com>

<http://aubethermostatmanual.com>

Golf course search by state

<http://golfingnear.com>

Email search by domain

<http://emailbydomain.com>

Auto manuals search

<http://auto.somanuals.com>

TV manuals search

<http://tv.somanuals.com>