

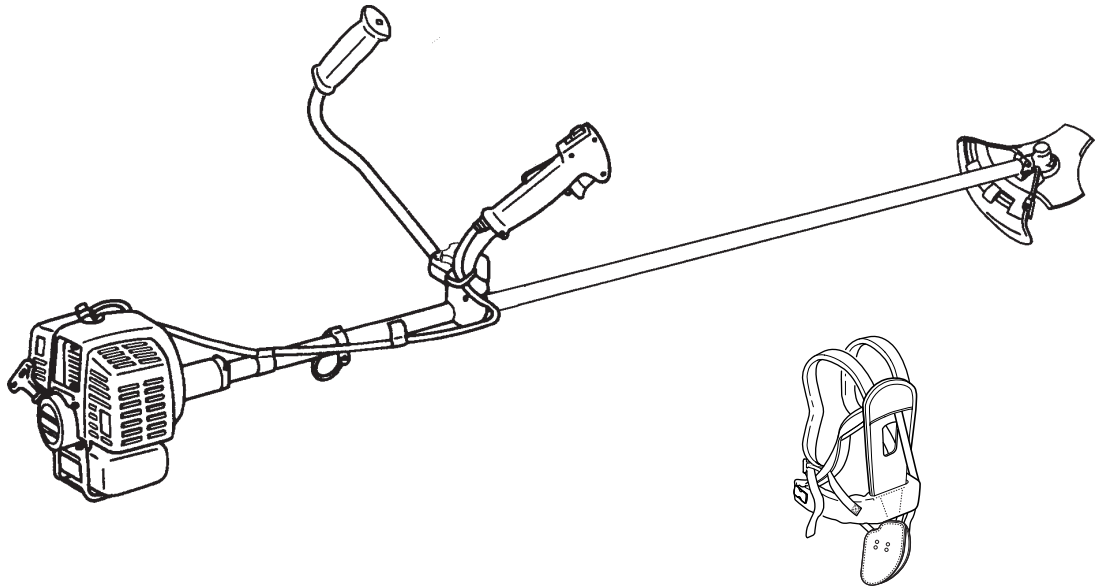

GB ENGLISH



# OPERATOR'S MANUAL

## GRASS TRIMMER/ BRUSHCUTTER

### SRM-2305



**WARNING**  **DANGER**

**READ INSTRUCTIONS CAREFULLY AND FOLLOW RULES FOR  
SAFE OPERATION.  
FAILURE TO DO SO COULD RESULT IN SERIOUS INJURY.**

X771-000 54 2

X771 227-540 2

© 2005  **KIORITZ CORPORATION**

Printed in Japan 0512Bkf 1052 ES

# INTRODUCTION

ECHO Grass Trimmers/Brushcutters are lightweight, high-performance, petrol engined units designed for weed control, grass trimming and brush cutting in areas difficult to control by any other means.

This Manual provides the information necessary for assembly, operation and maintenance. You must read this Manual to understand the safe and effective operation of your ECHO product.

## CONTENTS

Introduction .....	2	Assembling .....	13
Decals and symbols .....	2	Fuel .....	17
Rules for safe operation .....	3	Operation .....	17
Rules for safe operation (with metal blade) .....	8	Maintenance and care .....	19
Rules for safe operation (with nylon line cutting head) .....	10	Trouble shooting .....	22
Description .....	12	Storage .....	23
		Specifications .....	24
		Declaration "CE" of conformity .....	25

## DECALS AND SYMBOLS

Symbol form/shape	Symbol description/application	Symbol form/shape	Symbol description/application
	Carefully read the operator's manual		Warning, side thrust
	This symbol accompanied by the words <b>WARNING</b> and <b>DANGER</b> calls attentions to an act or a condition which can lead to serious personal injury or death.		The maximum speed of the cutting attachment shaft in r/min
	Circle and slash symbol means whatever is shown is prohibited.		Keep bystanders away 15 m
<b>CAUTION</b>	<b>CAUTION</b> indicates a potentially hazardous situation which, if not avoided, may result in minor or moderate injury.		Petrol and oil mixture
	Wear eyes, ears and head protection		Purge bulb (Primer)
	Wear foot protection and gloves	<b>L</b>	Carburettor adjustment - Low speed mixture
	Emergency stop	<b>H</b>	Carburettor adjustment - High speed mixture
	Warning! Thrown objects!	<b>T</b>	Carburettor adjustment - Idle speed
	Usage without shield not permitted		Guaranteed sound power level
		<b>NOTE</b>	This enclosed message provides tips for use, care and maintenance of the unit.

Locate this safety decal on your unit. The complete unit illustration found in the "DESCRIPTION" section will help you locate them.

Make sure the decal is legible and that you understand and follow the instructions on it. If a decal cannot be read, a new one can be ordered from your ECHO dealer.

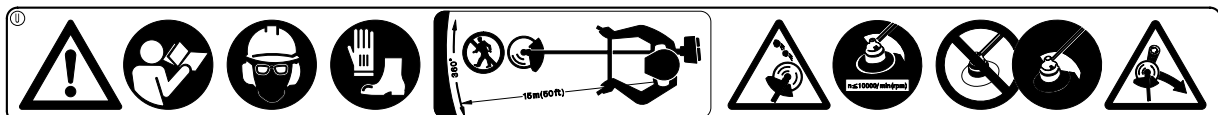

Part Number 890617-43130

Operator's manual



## RULES FOR SAFE OPERATION

### TRAINING

**WARNING**  **DANGER**  
GRASS TRIMMERS AND BRUSHCUTTERS CAN THROW SMALL GRAVEL, STONE, GLASS, METAL OR PLASTIC OBJECTS AS WELL AS THE MATERIAL BEING CUT. READ THESE "RULES FOR SAFE OPERATION" WITH CARE. FOLLOW INSTRUCTIONS IN THE OPERATOR'S MANUAL.

Read the Operator's Manual carefully. Be thoroughly familiar with the controls and proper use of the unit.  
Know how to stop the unit and shut off the engine.  
Know how to unhook a harnessed unit quickly.  
Never allow anyone to use the unit without proper instruction.

- If you have any questions or problems, please contact your ECHO dealer.

Wear eye protection

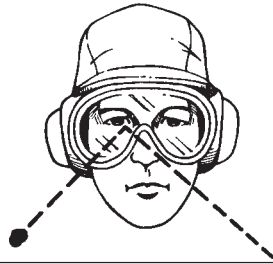

### EYE PROTECTION

The operator must wear eye protection not only against objects thrown by the unit, but also because eye infections can be caused by airborne dust, seeds and pollen.  
Prescription glasses may be worn under the safety goggles.  
Eye protection should also be worn by persons in the risk zone which extends beyond the danger zone.

Earmuffs Earplugs



### HEARING AND EAR PROTECTION

Prolonged exposure to loud noise can cause impairment or loss of hearing.  
Wear a suitable hearing protective device such as earmuffs or earplugs to protect against objectionable or uncomfortable loud noises.



### PROTECTIVE CLOTHING

Choose trousers, shirts and jackets that fit trimly and have no strings, frills or dangling straps which could catch on the unit or the underbrush. Do not wear ties, loose clothing or jewellery. Keep clothing buttoned or zipped up and shirt tails tucked in. Secure hair so it is above shoulder length.  
The wearing of gloves offers some protection against contact with skin irritants such as poison ivy. Soft leather work gloves may also improve your grip.

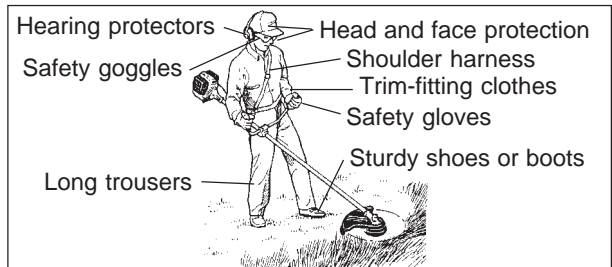

### ADDITIONAL PROTECTION

Hay fever (Rhinitis) sufferers may wear disposable masks to help reduce the intake of allergenic particles.

**Balance tool for a level plane of cutting head rotation**

Harness quick-release pin

Suspension point

Ground level

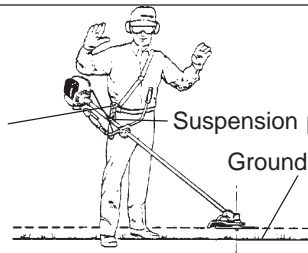

**WARNING**  **DANGER**

IN ADDITION TO HEAD, EYE AND EAR PROTECTION WEAR PROTECTIVE CLOTHES, SAFETY GLOVES AND SHOES TO PROTECT YOUR FEET AND BODY FROM THROWN OBJECTS, AND IMPROVE YOUR FOOTING ON SLIPPERY SURFACES. DO NOT WEAR TIES, JEWELLY, OR LOOSE, DANGLING CLOTHING WHICH COULD BE CAUGHT IN THE UNIT. DO NOT WEAR OPENTOED FOOTWEAR, OR GO BARE-FOOT OR BARELEGGED. IN CERTAIN SITUATIONS, TOTAL FACE AND HEAD PROTECTION MAY BE REQUIRED. FOR HEAVY BRUSH CUTTING WITH METAL BLADE, LOGGER'S TROUSERS OR LEG CHAPS WITH PROTECTIVE INSERTS ARE ADDED CONSIDERATIONS.

**PREPARATION**

Use a shoulder harness when provided or when recommended in this manual. Adjust both harness and the suspension point on the unit so the unit hangs with the cutting attachment a few centimetres above ground level. The cutting attachment and shield should be level in all directions. Harness the unit on the right side as shown.

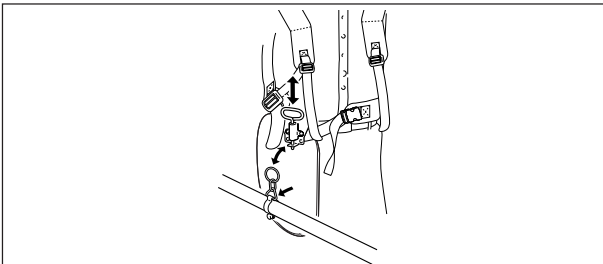

- a) Slide suspension point up and down the tube to find the right balance. Rotate the clamp to level the cutting attachment and shield. Lock in position. If the suspension point is a free-spinning type, the unit may tend to roll over sideways, however, you should still level the attachment and shield on the front-to-rear axis.
- b) Balancing and levelling, as above, may require relocation of the clamp and readjustment of the harness straps. Also, each type of cutting attachment and shield mounted on the unit may require balancing.

**NOTE**

A person's size can affect the balancing adjustment. Also the balancing procedure may not work with some ECHO units on some persons. If the procedure does not work for you, please ask your ECHO servicing dealer for assistance.

**WARNING**  **DANGER**

**ECHO TRIMMERS AND BRUSHCUTTERS ARE DESIGNED TO FIT A WIDE VARIETY OF BODY SIZES, BUT MAY NOT BE ADJUSTABLE FOR EXTREMELY TALL PERSONS. DO NOT USE THE UNIT IF YOUR FEET CAN REACH THE CUTTING ATTACHMENT WHEN THE UNIT IS ATTACHED TO THE HARNESS.**

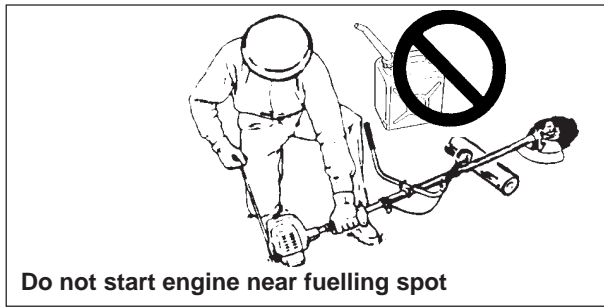

**Do not start engine near fuelling spot**

### FUEL

It is highly flammable.

- a) Use an appropriate type of fuel container.
- b) Do not smoke or bring flame or sparks near to fuel supplies.
- c) The fuel tank may be under pressure. Always loosen the fuel cap and wait for pressure to be equalized before removing the cap.
- d) Fill the fuel tank outdoors over bare ground and install the fuel cap securely. Do not pour fuel indoors.
- e) Wipe any spilled fuel off the unit. Then move at least 3 m from the fuelling spot before starting the engine.
- f) Never refuel while the engine is still hot, or fuel a running engine.
- g) Do not store the unit with fuel in its tank, because a fuel leak could start a fire.

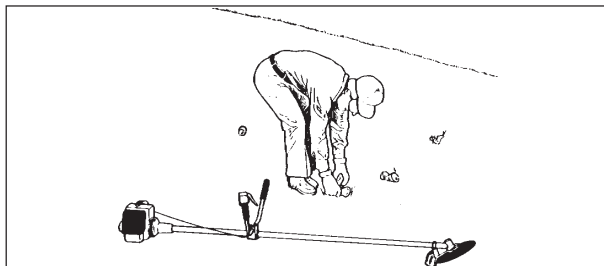

### AREA AND EQUIPMENT INSPECTION

Inspect the area before using the unit. Remove objects the unit could throw. Remember where there are obstructions to be avoided.

Inspect the unit before using it. Perform only maintenance or adjustments for which the operator's Manual gives instruction. Do not try to repair the unit without proper instruction. The unit should be serviced only by trained ECHO dealer servicemen with the proper tools.

Be sure that:

- a) Engine does not leak fuel.
- b) Fasteners are tight, and none are missing.
- c) Silencer is in good condition.
- d) The unit has the proper equipment-shield, handles, harness, etc.-for the cutting attachment to be used.
- e) If used on the unit, the cutting attachment is properly tightened.



### PHYSICAL CONDITION

You should be in good mental and physical health. Do not operate if you are under the influence of alcohol or any medication or substance which could affect your vision, dexterity or judgement.

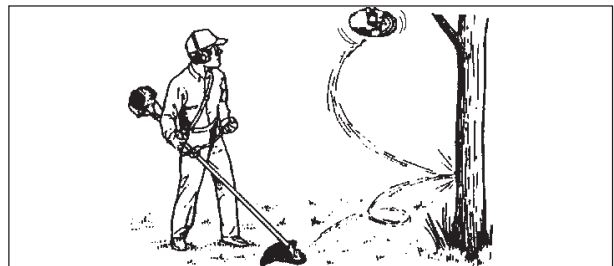

### WARNING DANGER

- IMPROPER FIT WILL RESULT FLY OFF THE CUTTING ATTACHMENT.
- NEVER START THE ENGINE IF THE POWER TRANSMISSION SHAFT IS NOT IN PLACE TO PREVENT THE ENGINE FROM OVER SPEEDING OR THE CLUTCH FROM FLYING APART.



**GENERAL OPERATION**

Engine fumes contain deadly poisonous carbon monoxide.

Do not operate with a worn or damaged cutting attachment.

Do not run engine at full throttle without a load.

Do not hit rocks, stones, tree stumps, and other foreign objects with the cutting attachment.

If cutting attachment strikes an obstruction, stop engine immediately and inspect cutting attachment for damage.

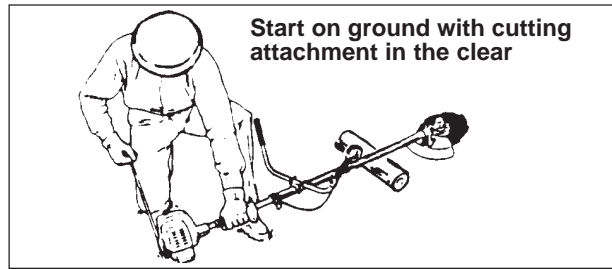

Lay the unit down on a clear area and set the controls for starting. Be sure the cutting attachment cannot contact the ground or any obstruction.

Hold the unit firmly down so you will not lose control during starting. Do not start the unit in the air, or from the harness. The unit could swing into your leg or an obstruction if you lose control.

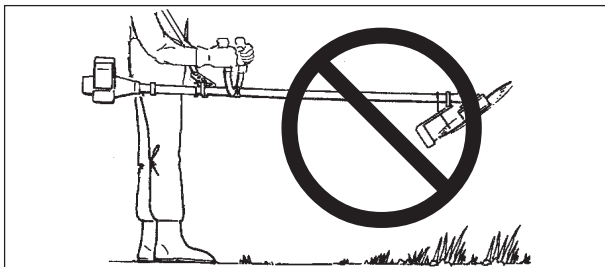

Do not raise the cutting attachment above knee height. If raised higher, the cutting attachment will be more directly in line with your face. Thrown objects may hit your face and eyes.

Wear the recommended protective gear.

Never operate the unit without the proper guards, shoulder harness and other protective devices.

Never operate the unit without good visibility and light.

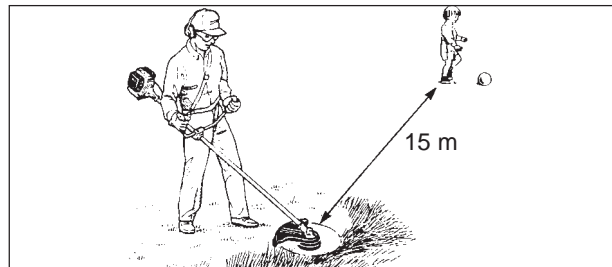

Do not allow anyone to enter the operating DANGER ZONE with you. The danger zone is an area of 15 m in radius.

Insist that persons in the RISK ZONE beyond the danger zone wear eye protection to protect them from thrown objects. If the unit must be used where there are unprotected people, operate at a low throttle speed to reduce the risk.

Ensure that there are no children, bystanders, and pets in the work area. Keep all children, bystanders and fellow workers outside 15 m radius for brushcutters/ grasstrimmers.

Stop the engine before leaving the machine, children are not allowed to use the machine, stop the machine between different working places.

If you are approached, stop the engine and cutting attachment immediately. Keep your hands and body away from silencer to prevent heat injury while the engine is hot.

**WARNING**  **DANGER**  
**EYE PROTECTION SHOULD BE CONSIDERED FOR EVERYONE IN THE ZONE OF RISK. RISK OF EYE INJURY DIMINISHES WITH DISTANCE.**



Shut down immediately if the unit starts to shake or vibrate.

A sudden vibration is a sign there may be dangerous trouble, such as a broken flywheel, clutch or cutting attachment, or loose parts.

Do not use the unit until the problem has been properly diagnosed and corrected.

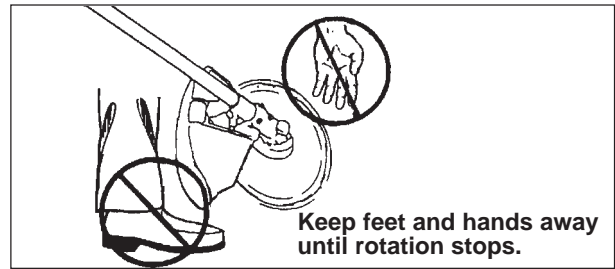

When the unit is turned off, make sure the cutting attachment stops before the unit is set down.

A cutting attachment can injure while it continues to spin after the engine is shut off or throttle control is released.

If the cutting attachment rotates after throttle is returned to idle, carburettor adjustment is required. Follow instruction on this manual to make the adjustment yourself, or have the carburettor adjusted by your ECHO dealer.

All maintenance and adjustments given in this manual should be performed by you or your ECHO servicing dealer on a timely basis.

All required service or repair must be done only by ECHO servicing dealer. Never attempt to use an incomplete or one fitted with unauthorized modification.

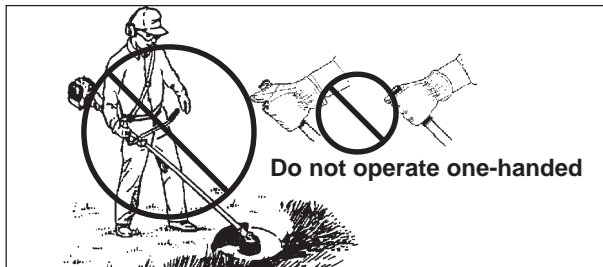

Always use both hands on the handles. Do not operate one-handed.

Always hold the unit with the fingers and thumbs encircling the handles.

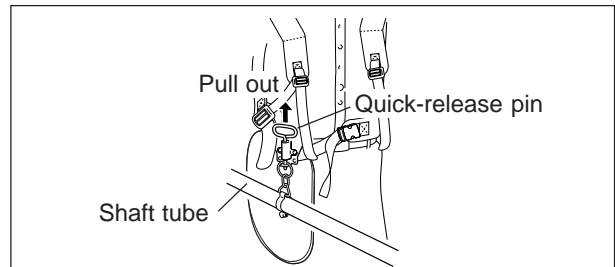

**WARNING**  **DANGER**  
**IN CASE OF AN EMERGENCY, USE QUICK-RELEASE PIN ON HARNESS TO FREE YOURSELF FROM UNIT.**



### VIBRATION AND COLD

It is believed that a condition called Raynaud's Phenomenon which affects the fingers of certain individuals may be brought about by exposure to vibration and cold. Exposure to vibration and cold may cause tingling and burning, followed by loss of colour and numbness in the fingers.

The following precautions are strongly recommended because the minimum exposure which might trigger the ailment is unknown.

- Keep your body warm, especially the head and neck, feet and ankles, and hands and wrists.
- Maintain good blood circulation by performing vigorous arm exercises during frequent work breaks, and also by not smoking.
- Limit the number of hours of operation. Try to fill each day with jobs where operating the trimmer or other hand-held power equipment is not required.
- If you experience discomfort redness and swelling of the fingers, followed by whitening and loss of feeling, consult your physician before exposing yourself further to cold and vibration.

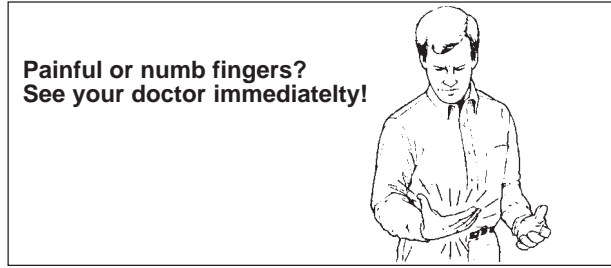
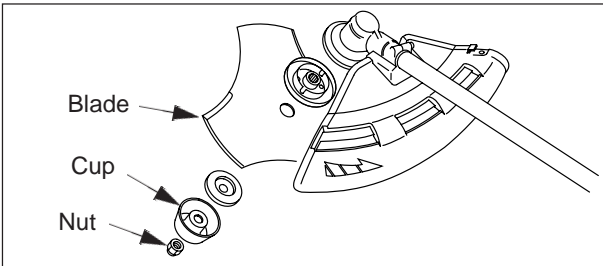

### REPETITIVE STRESS INJURIES

It is believed that over-using the muscles and tendons of the fingers, hands, arms and shoulders may cause soreness, swelling, numbness, weakness and extreme pain to the areas just mentioned. Certain repetitive hand activities may put you at a high risk for developing a repetitive stress injury (RSI).

To reduce the risk of RSI, do the following:

- Avoid using your wrist in a bent, extended or twisted position.
- Take periodic breaks to minimize repetition and rest your hands. Reduce the speed and force in which you do the repetitive movement.
- Do exercises to strengthen hand and arm muscles.
- See a doctor if you feel tingling, numbness or pain in your fingers, hands, wrists or arms. The sooner RSI is diagnosed, the more likely permanent nerve and muscle damage can be prevented.

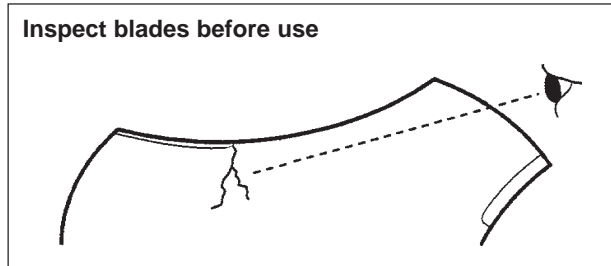

## RULES FOR SAFE OPERATION (WITH METAL BLADE)

### USE CORRECT BLADE

#### WARNING DANGER

- SERIOUS INJURY MAY RESULT FROM THE IMPROPER USE OF BLADES. READ AND COMPLY WITH ALL SAFETY INSTRUCTIONS LISTED IN THIS MANUAL.
- THE 3 CUTTER BLADE IS DESIGNED ESPECIALLY TO CUT WEEDS AND GRASS. TO AVOID INJURY DUE TO KICKBACK OR BLADE FRACTURE, DO NOT USE THE 3 CUTTER BLADE TO CUT BRUSH OR TREES.
- USE ONLY CUTTING ATTACHMENTS RECOMMENDED BY KIORITZ CORPORATION.

#### WARNING DANGER

PIECES FROM A CRACKED METAL BLADE CAN FLY OFF DURING OPERATION. INSPECT METAL BLADES FOR CRACKS BEFORE EACH USE. DISCARD CRACKED BLADES NO MATTER HOW SMALL THE CRACK. CRACKED BLADES CAN BE THE RESULT OF MISUSE OR IMPROPER SHARPENING.



**Wires can catch and flap around**

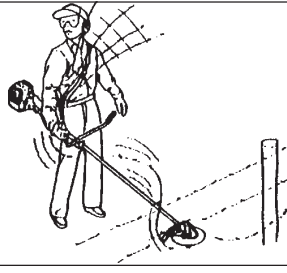

- Always use the blade suited for the job.
- Do not hit rocks, stones, tree stumps, and other foreign objects with the blade.
- Do not cut into the ground with the blade.
- If blade strikes an obstruction, stop engine immediately and inspect blade for damage.
- Do not operate with a dull, bent, fractured or discoloured blade and worn or damaged nut.
- Do not run engine at full throttle without a load.
- Remove all foreign objects from work area.
- Do not operate brushcutter without shoulder harness and shield.

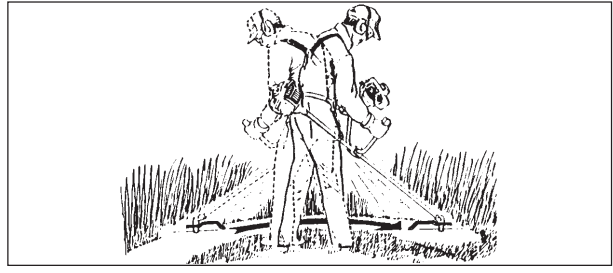

**SCYTHING WEEDS.** This is cutting by swinging the cutting attachment in a level arc. It can quickly clear areas of field grass and weeds. Scything should not be used to cut large, tough weeds or woody growths.

If a sapling or shrub binds the cutting attachment, do not use the cutting attachment as a lever to free the bind, because this will cause cutting attachment failure.

Instead, shut off the engine and push the sapling or shrub to free the blades.

Do not use a cracked or damaged blade.

**WARNING ⚠ DANGER**

**ALWAYS STOP THE ENGINE WHEN A CUTTING ATTACHMENT JAM OCCURS. DO NOT ATTEMPT TO REMOVE AN OBJECT CAUSING A JAM IF THE ENGINE IS RUNNING. SEVERE INJURY CAN OCCUR IF A JAM IS REMOVED AND THE CUTTING ATTACHMENT SUDDENLY STARTS.**

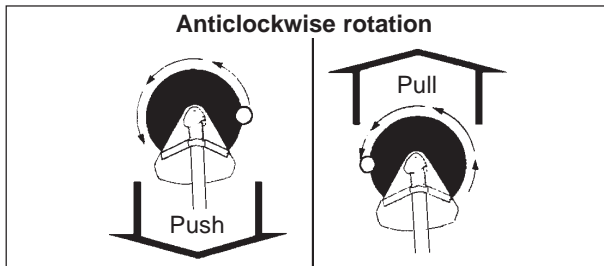

**REACTION FORCES**

**WARNING ⚠ DANGER**  
**BE SURE YOU UNDERSTAND THE REACTION FORCES OF PUSH AND PULL, AND HOW THESE FORCES MAY AFFECT YOUR BALANCE IN THE OPERATION OF A UNIT.**

**PUSH.** The operator may feel the unit push toward him when he tries to cut the object on right. If he cannot hold the blade in the cut, a kickback may occur when the blade is pushed out to where the teeth at the outside furthest point from the operator are cutting. The blade will “kickback” sideways.

**PULL.** The opposite of push. When object on left, the operator may feel the unit pull away. Although this pull type of cutting may cause sawdust to be thrown back at the operator, it is recommended for sawing off heavy brush because the cutting is smoother and more stable than when the unit pushes.

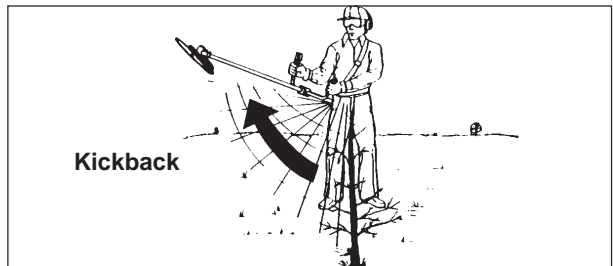

**KICKBACK.** This may occur when the moving blade at the front of the blade circle contacts strong brush or trees. The force that occurs pushes the entire unit and blade violently away in an arc. Kickback is a danger to a bystander and also a jolting force to the operator.

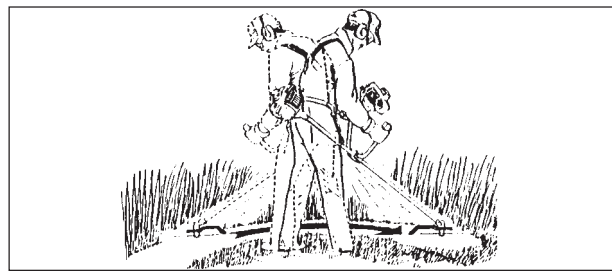
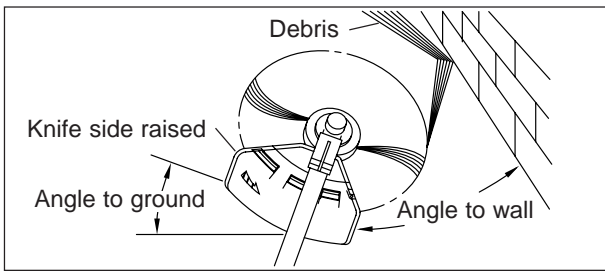

## RULES FOR SAFE OPERATION (WITH NYLON LINE CUTTING HEAD)

The basic cutting actions pictured are:  
Trimming, scything, scalping and lawn edging.  
These actions are as follows:

**TRIMMING:** This is feeding the trimmer carefully into the material you wish to cut. Tilt the head slightly to direct the debris away from you. If cutting up to a barrier such as a fence, wall or tree, approach from an angle where any debris ricocheting off the barrier will fly away from you. Move the line head or line disc slowly until the grass is cut right up to the barrier, but do not jam (overfeed) the line into the barrier. If trimming up to wire mesh or chain link fencing, be careful to feed only up to the wire. If you go too far, the line will snap off around the wire.

Trimming can be done to cut through weed stems one at a time. Place the nylon line cutter near the bottom of the weed never high up, which could cause the weed to chatter and catch the line. Rather than cut the weed right through, just use the very end of the line to wear through the stem slowly.

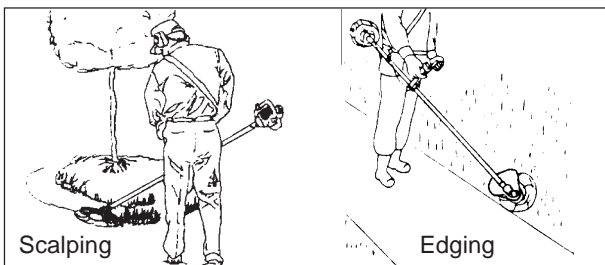

**SCALPING AND EDGING:** Both of these are done with the line head or line disc tilted at a steep angle. Scalping is removing top growth, leaving the earth bare. Edging is trimming the grass back where it has spread over a pavement or driveway. During both edging and scalping, hold the unit at a steep angle in a position where the debris, and any dislodged dirt and stone, will not come back towards you even if it ricochets off the hard surface.

Although the pictures show how to edge and scalp, every operator must find for himself the angles which suit his body size and cutting situation.

**SCYTHING:** This is the cutting or mowing of large grassy areas by sweeping or swinging the trimmer in a level arc. Use a smooth, easy motion. Do not try to hack or chop down the grass. Tilt the line head or line disc to direct the debris away from you on the scything stroke. Then return without cutting grass for another stroke. If you are well protected and do not care whether some debris is thrown in your direction, you may scythe in both directions.

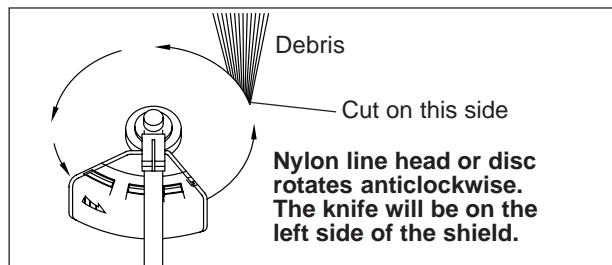

For nearly all cutting, it is good to tilt the nylon cutter so that contact is made on the part of line circle where the line is moving away from you and the shield (See appropriate picture). This results in the debris being thrown away from you.

Tilting the head to the wrong side will shoot the debris toward you. If the nylon line cutter is held flat to the ground so that cutting occurs on the whole line circle, debris will be thrown at you, drag will slow the engine, and you will use up a lot of line.

**WARNING**  **DANGER**  
USE ONLY FLEXIBLE, NON-METALLIC LINE  
RECOMMENDED BY KIORITZ CORPORATION.

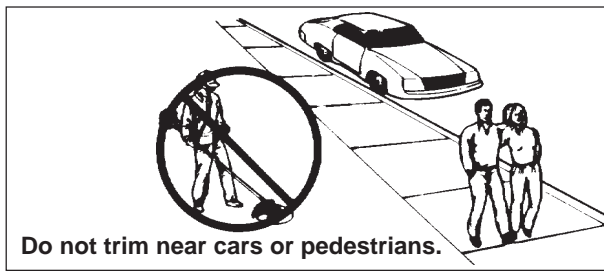

Do not trim near cars or pedestrians.

**WARNING**  **DANGER**  
**USE EXTREME CAUTION WHEN OPERATING OVER BARE SPOTS AND GRAVEL, BECAUSE THE LINE CAN THROW SMALL ROCK PARTICLES AT HIGH SPEEDS. THE SHIELD ON THE UNIT CANNOT STOP OBJECTS WHICH BOUNCE OR RICOCHET OFF HARD SURFACES.**

Always wear proper eye protection against thrown objects. Objects can bounce up at you from the ground under the shield, or ricochet off any nearby hard surface.

Do not trim at high speed near roadways when there is traffic, or in places where there are pedestrians. If you must trim where people are in the zone of risk use a much lower or reduced speed, by using a partial trigger setting. Do not use full throttle.

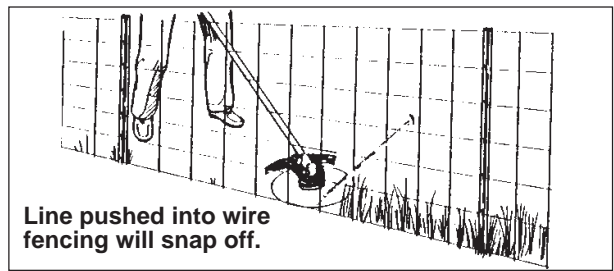

Line pushed into wire fencing will snap off.

Do not push the line into tough weeds, trees, or wire fences. Pushing the line into chicken wire, chain link fencing or thick brush can result in snapped-off line ends being hurled back at the operator. The proper way is to cut right up to a barrier, such as any of those mentioned, but never run the line into or through the obstruction. Do not cut closely to obstruction or barrier.

**WARNING**  **DANGER**  
**ALWAYS STOP THE ENGINE WHEN A CUTTING ATTACHMENT JAM OCCURS. DO NOT ATTEMPT TO REMOVE AN OBJECT CAUSING A JAM IF THE ENGINE IS RUNNING. INJURY CAN OCCUR IF A JAM IS REMOVED AND THE CUTTING ATTACHMENT SUDDENLY STARTS.**

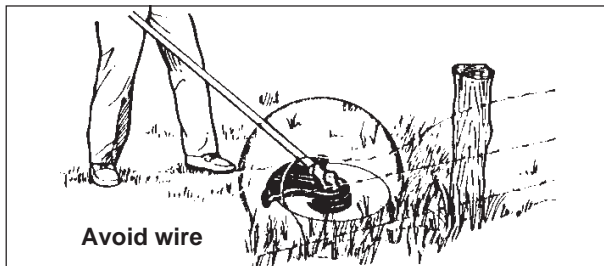

Avoid wire

Avoid nylon line contact with broken wire fencing. Pieces of wire broken off by the trimmer can be hurled at high speeds.

**WARNING**  **DANGER**  
**DO NOT TRIM IN ANY AREA WHERE THERE ARE BROKEN STRANDS OF FENCING WIRE. REMOVE THE BROKEN PIECES OF WIRE, OR GIVE THE AREA WIDE BERTH. WEAR PROPER SAFETY PROTECTION. DO NOT CUT WHERE YOU CANNOT SEE WHAT THE CUTTING DEVICE IS CUTTING.**

F-4/10

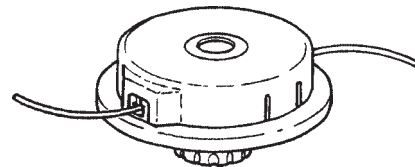

**USE CORRECT CUTTING ATTACHMENT**

**WARNING**  **DANGER**

- SERIOUS INJURY MAY RESULT FROM THE IMPROPER USE OF CUTTING ATTACHMENT. READ AND COMPLY WITH ALL SAFETY INSTRUCTIONS LISTED IN THIS MANUAL.
- USE ONLY CUTTING ATTACHMENTS RECOMMENDED BY KIORITZ CORPORATION.

**WARNING**  **DANGER**  
**EXCESSIVE NYLON LINE BEYOND CUT OFF KNIFE COULD FLY OFF WHEN THE NYLON LINE CUTTER STARTS ROTATING AFTER ADJUSTMENT OF NYLON LINE LENGTH.**

**WARNING**  **DANGER**  
**USE ONLY NYLON LINE. DO NOT USE ANY TYPE OF METAL BLADE.**

## DESCRIPTION

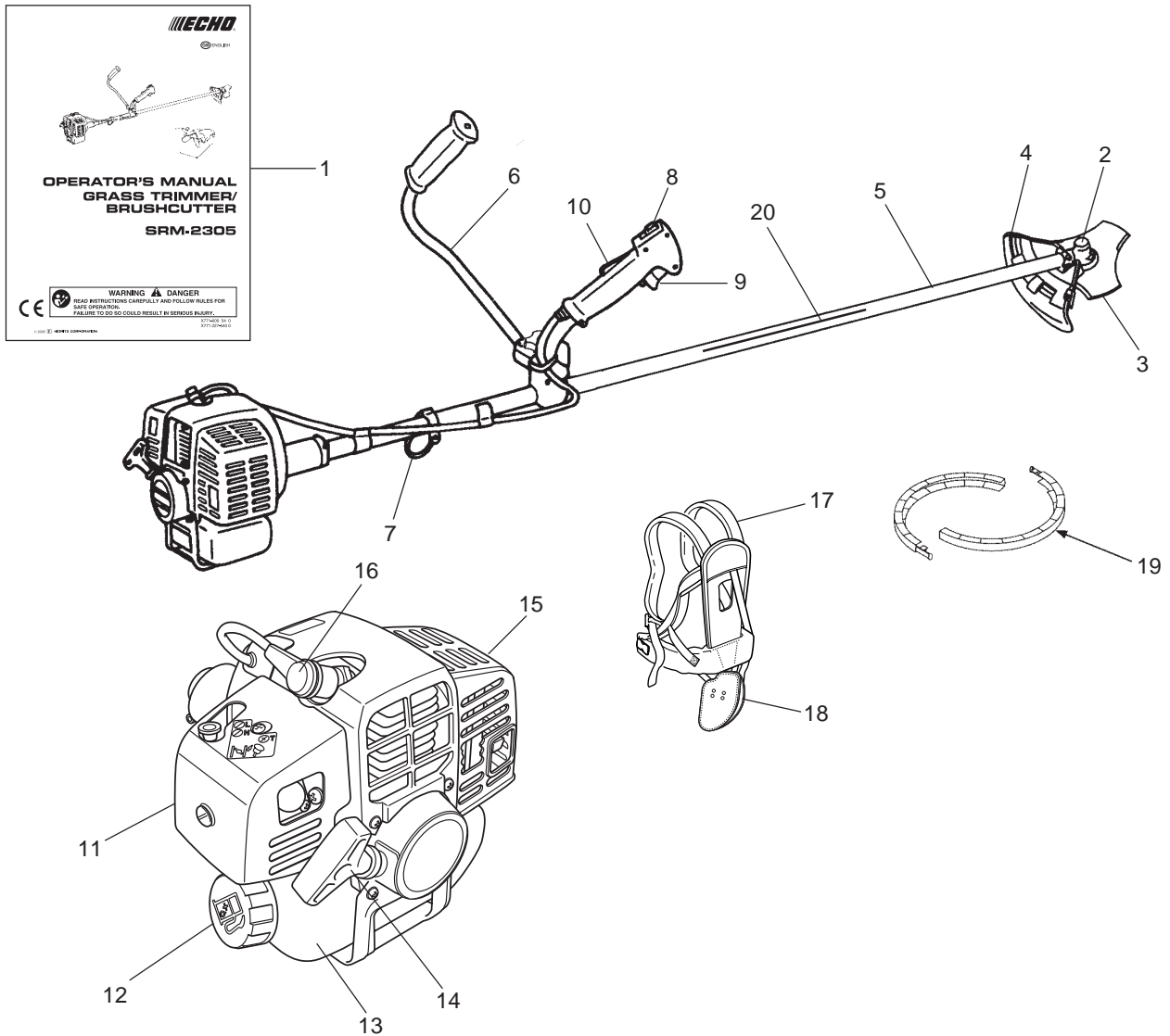

- 1 **OPERATOR'S MANUAL** Included with unit. Read before operation and keep for future reference to learn proper, safe operating techniques.
- 2 **ANGLE TRANSMISSION** Having two gears to change the angle of rotating axis.
- 3 **3 CUTTER BLADE** For cutting grass, garden debris and weeds.
- 4 **SHIELD** Device to protect the operator from accidental contact with the cutting head and thrown objects.
- 5 **SHAFT TUBE** Part of the unit that provides a casing for power transmission shaft.
- 6 **U-HANDLE** Having the configuration of a bicycle handle bar.
- 7 **SUSPENSION POINT** Device on which the harness can be hooked.
- 8 **IGNITION SWITCH** "Slide Switch" mounted on top of the Throttle Trigger Housing, move switch upward to RUN, downward to STOP position.
- 9 **THROTTLE TRIGGER** Activated by the operator's finger for controlling the engine speed.
- 10 **THROTTLE TRIGGER LOCKOUT** Locks throttle trigger in the idling position until you have a proper grip with your right hand around the handle.
- 11 **AIR CLEANER COVER** Covers air filter.
- 12 **FUEL TANK CAP** For closing the fuel tank.
- 13 **FUEL TANK** Contains fuel and fuel filter.
- 14 **STARTER HANDLE** Pull handle to start the engine.
- 15 **SILENCER COVER** Cover the silencer not to make operator touch to hot surface of silencer.
- 16 **SPARK PLUG**
- 17 **SHOULDER HARNESS** An adjustable strap to suspend unit.
- 18 **HIP PAD** To protect hip/leg and clothing.
- 19 **BLADE COVER** When transporting the unit, use the appropriate metal blade cover.
- 20 **SAFETY DECAL** Part Number 890617-43130

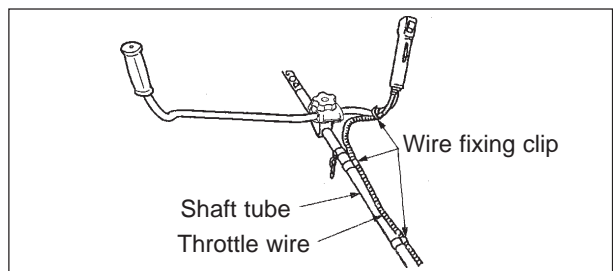
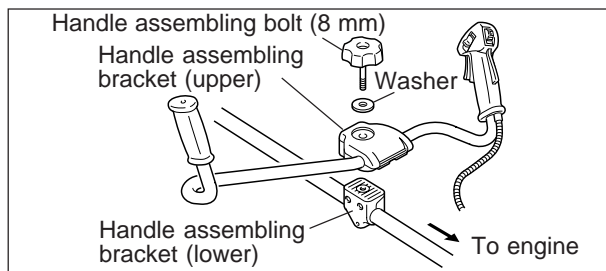

## ASSEMBLING

Install handle assembling bracket (upper) in handle assembling bracket (lower) and fix handle by tightening handle assembling bolt (8 mm) lightly.

Adjust inclination of handle to adequate position (easy to operate) and tighten firmly handle assembling bolt (8 mm).

To eliminate loosening of throttle wire fix it to shaft tube (2 places) and to right hand U-handle (1 place) with wire fixing clips.

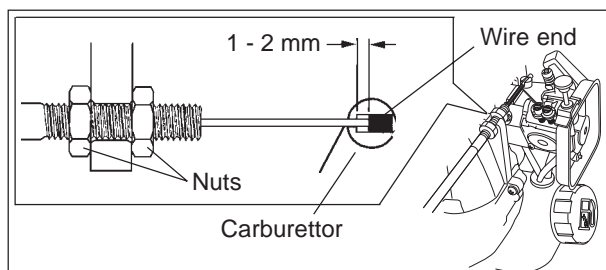

### CAUTION

After assembly, adjust the play of wire end on carburettor side to 1 mm - 2 mm.

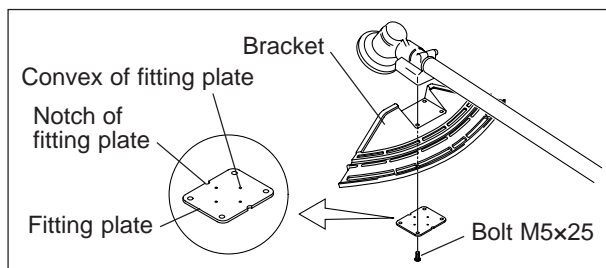

### INSTALLATION OF BRACKET

Fit bracket to mounting portion of angle transmission and fix the bracket by holding fitting plate pressed from beneath and tightening 4 bolts (M5x25) lightly.

Get notches and convexes of fitting plate to face corresponding convexes and concaves of bracket, and fix bracket tightening 4 bolts (M5x25) securely.

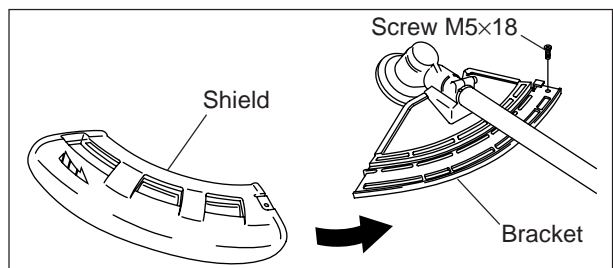

There are two types of shields: namely one used exclusively for Nylon line and another one used exclusively for steel blade. When Nylon line is used, use the shield for Nylon line. When steel blade is used, use the shield for steel blade.

### METHOD TO CHANGE SHIELD (FOR STEEL BLADE)

Remove screw (M5x18) on the right side of the shield and slide the shield to the left and remove it. Put shield of another type into groove and slide it to the right until it stops and be sure to fasten with the removed screw (M5x18). When using Nylon line, use the shield for Nylon line (see page 15). Fit cut off knife to the shield for Nylon line using screw (5x12).

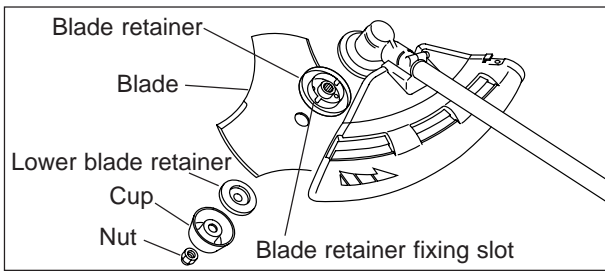

### INSTALLING BLADE

Inspect blades before installation. Check for sharpness. Dull blades increase the risk of blade kickback reactions. Small cracks can develop into fractures resulting in a piece of blade flying off during operation.

Discard cracked blades no matter how small the crack.

Blade retainer, blade, lower blade retainer, cup and nut finger tight.

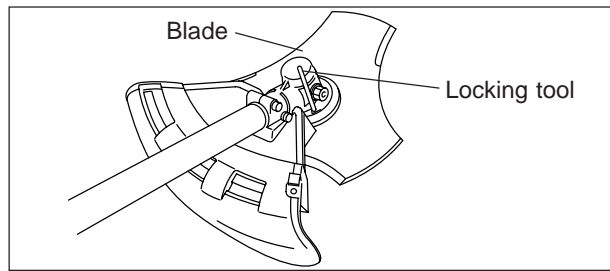

Insert locking tool into a hole located on the right side of angle transmission while forcing retainer spring to the left side. Insert locking tool further into blade retainer fixing slot to fix output shaft.

### CAUTION

**Fasten output shaft using locking tool securely in order to avoid the possibility of output shaft rotating when mounting cutting blade which will prevent the cutting blade fastening nut from being tightened sufficiently.**

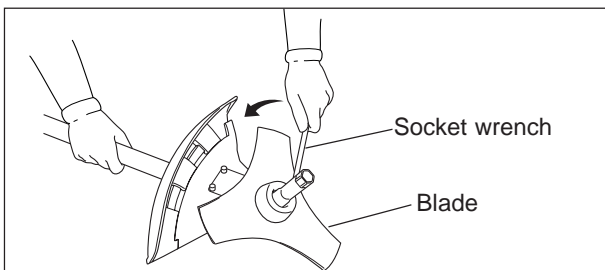

Tighten the nut (turn anticlockwise) using a socket wrench. Never fasten while applying your weight. Otherwise the thread of nut could be broken. Replace nut and cup with new ones no matter how small the wear is.

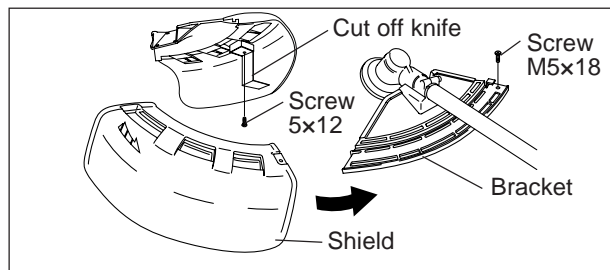

### METHOD TO CHANGE SHIELD (FOR NYLON LINE)

Remove screw (M5x18) on the right side of the shield and slide the shield to the left and remove it. Put shield of another type into groove and slide it to the right until it stops and be sure to fasten with the removed screw (M5x18).

**WARNING ⚠ DANGER**  
**IF WORN NUT AND CUP FOR BLADE ARE USED, THERE IS A DANGER OF BLADE GETTING LOOSE. REPLACE THEM WITH NEW ONES.**

**CAUTION**  
**Wear gloves to reduce the risk of injury caused by unintentional contact with the blade.**

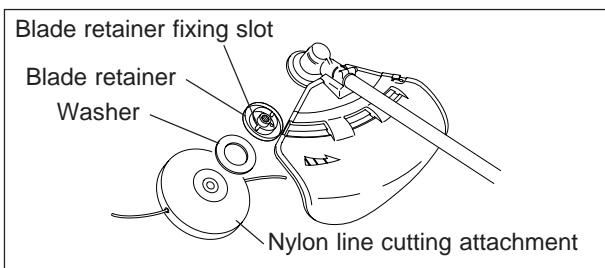

### INSTALLING NYLON LINE CUTTING ATTACHMENT

Insert locking tool into a hole located on the right side of angle transmission while forcing retainer spring to the left side. Insert locking tool further into blade retainer fixing slot to fix output shaft.

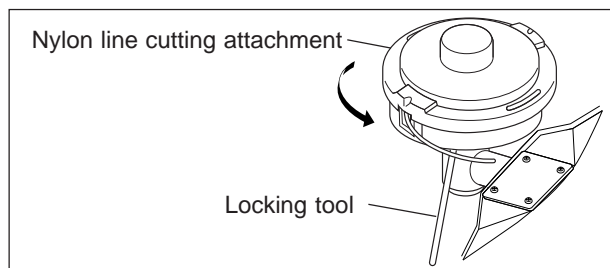

### CAUTION

**Fasten output shaft using locking tool securely in order to avoid the possibility of output shaft rotating when mounting nylon line cutting attachment.**

Thread cutting attachment onto shaft (anticlockwise) until it is tight. Remove locking tool.

F-4/10

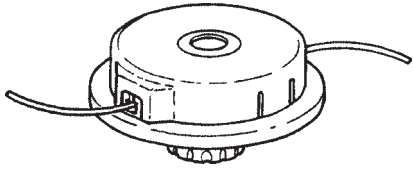

### NYLON LINE CUTTING ATTACHMENT

Type: F-4/10

Thread: Left-hand thread M10 x 1.25 pitch

#### CAUTION

Use only flexible, non-metallic line recommended by KIORITZ CORPORATION.

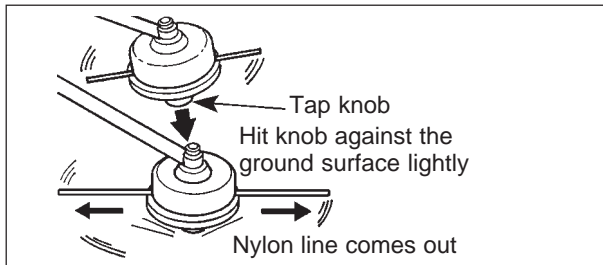

### ADJUSTING NYLON LINE

- Make sure there is no bystander within 15 m radius and pay enough attention to objects in the surroundings before starting operation.
- Do not rotate the cutting head at more than 10,000 r/min.
- Do not hit the cutting head against hard foreign matters such as rocks, concrete, tree stub and bottle etc.

- When releasing Nylon line from spool hit tap knob of spool against the ground surface lightly at rotation speed lower than 4,500 r/min.
- Cut off knife on the guard adjusts cutting swath to 40 cm automatically by cutting nylon lines evenly when attachment starts rotating.
- When operating with less than maximum cutting swath (40 cm), cut two nylon lines in equal lengths.

### REPLACING NYLON LINE

**WARNING**  **DANGER**  
SHUT DOWN TRIMMER ENGINE WITHOUT FAIL  
AND MAKE SURE CUTTING HEAD HAS STOPPED  
ROTATING BEFORE STARTING REPLACEMENT  
PROCEDURE.

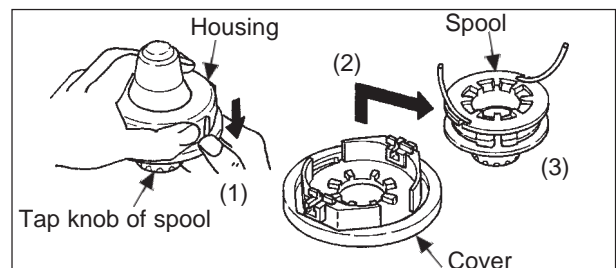

- (1) Press "retaining pawls" (at two places) inward and remove cover.  
It is easier to remove one after another.
- (2) Remove spool.
- (3) When Nylon line on the spool is almost exhausted, remove remaining line from spool and wind "new line" according to the procedures (4) and beyond.  
When the line on the spool is "melted and stuck" remove the entire line while peeling off the "melted and stuck" portion and wind the "removed line" anew according to procedures (4) and beyond.

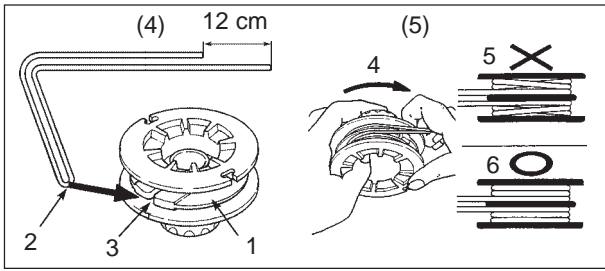

1. Intermediate separator
  2. Bent portion
  3. Notch Nylon line
  4. Winding direction for the line
  5. If wound unfirmly, the line loosens.
  6. Wind firmly into respective groove.
- (4) Bend the line at the point 12 cm away from the middle of whole length and hook the bent portion into the "notch" of the intermediate separator.
- (5) Wind the line firmly into groove of the spool following "winding direction for the line LH".

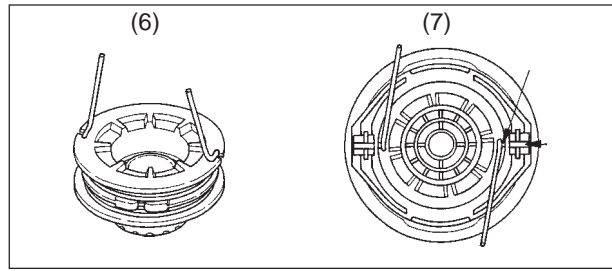

- (6) When the line is wound to the end hook both line ends into respective notch of spool for retaining tentatively the line while leaving line ends approximately 10 cm beyond notch.
- (7) Align notches of spool for the line with grooves of eyelets and fit spool into cover.

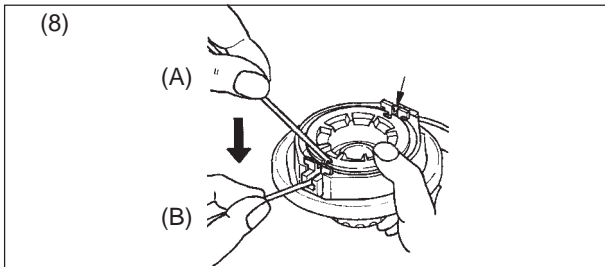

- (8) Pull out the line from cover.  
 (A) Remove the line from "respective notch of spool", and (B) pass it through "groove of respective eyelet".
- (9) Fit cover and housing together.  
 (C) Align "eyelets" of cover with "recesses" of housing, and (D) press pawls of housing into respective window of cover until the pawls are firmly fitted into the windows.

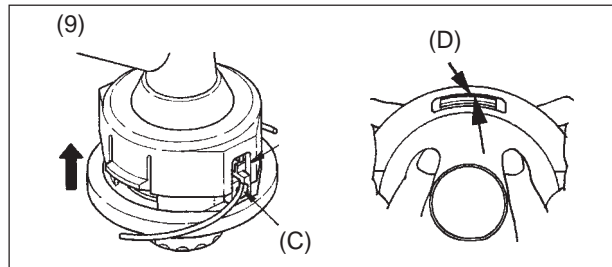

**WARNING**  **DANGER**  
**MAKE SURE EACH OUTER PERIPHERY OF PAWLS OF HOUSING SPREADS ALMOST FULLY UP TO THE OUTER PERIPHERY OF RESPECTIVE WINDOW OF COVER.**  
**IF THEY ARE LOOSELY FITTED AND THE CUTTING HEAD IS TURNED, COVER OR INSIDE COMPONENTS CAN FLY OFF WHICH IS DANGEROUS.**



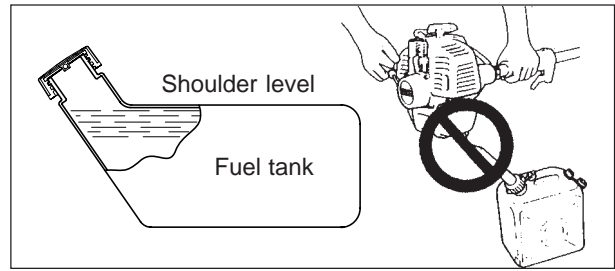
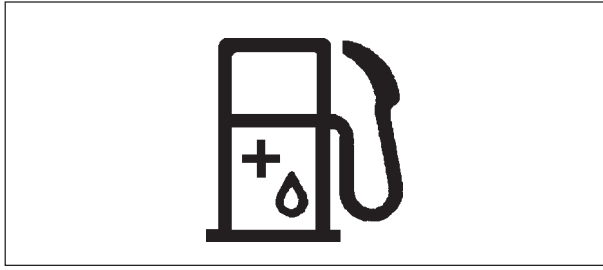

## FUEL

### FUEL

- Fuel is a mixture of regular grade petrol and an air-cooled 2-stroke engine oil of reputable brand name. Minimum 89 Octane unleaded petrol is recommended. Do not use fuel containing methyl alcohol or more than 10 % of ethyl alcohol.
- Recommended mixture ratio; 50 : 1 (2 %) for ISO-L-EGD Standard (ISO/CD 13738), JASO FC grade and ECHO Premium 50 : 1.
  - Do not mix directly in engine fuel tank.
  - Avoid spilling petrol or oil. Spilled fuel should always be wiped up.
  - Handle petrol with care, it is highly inflammable.
  - Always store fuel in approved container.

### NOTE

Stored fuel ages. Do not mix more fuel than you expect to use in thirty (30) days. Do not mix directly in fuel tank.

### HANDLING FUEL

**WARNING**  **DANGER**  
**AFTER REFUELLING, TIGHTEN FUEL CAP FIRMLY AND CHECK FOR LEAKAGE. IN CASE OF FUEL LEAKAGE, REPAIR BEFORE STARTING OPERATION SINCE THERE IS A DANGER OF FIRE.**

- Never smoke or allow flame or sparks near fuel.
- Always fill the fuel tank outdoors. Never pour fuel indoors.
- Always remove the fuel cap slowly to relieve any pressure buildup in the tank.
- Never refuel the engine when it is hot or running.
- Always use an approved, safe fuel container.
- It is not permitted to fill fuel above the shoulder level of fuel tank.
- After fuelling, always wipe away spilled fuel.
- Always move at least 3 m away from the fuelling spot before starting the engine.
- Never store the unit with fuel in the tank a fuel leak could start a fire.

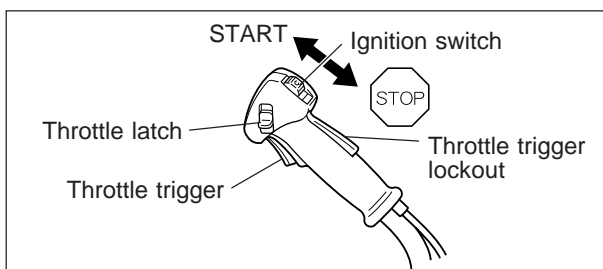

## OPERATION

### STARTING COLD ENGINE

#### **WARNING** **DANGER**

- WHEN ENGINE STARTS, THE CUTTING ATTACHMENT MAY ROTATE, EVEN WITH THROTTLE TRIGGER IN LOW-SPEED POSITION.
- WHEN ENGINE IS STARTED, CONFIRM IF THERE IS NOT ANY ABNORMAL VIBRATION OR SOUND. IF THERE IS ABNORMAL VIBRATION OR SOUND, ASK YOUR DEALER TO REPAIR.

#### **WARNING** **DANGER**

**WHEN STARTING ENGINE USING THROTTLE LATCH, CUTTING ATTACHMENT ROTATES. AFTER ENGINE STARTS, PULL THROTTLE TRIGGER SLIGHTLY TO RELEASE THROTTLE LATCH IMMEDIATELY. NEVER USE THROTTLE LATCH FOR OPERATION.**

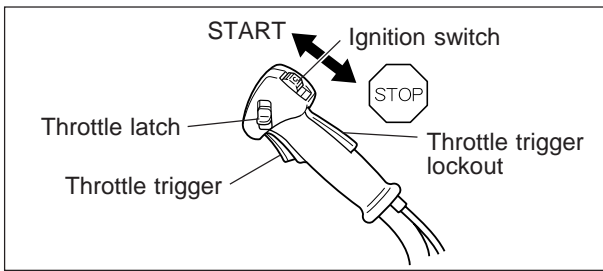

- Before starting engine make sure cutting attachment is not in touch with ground or other objects.
- Place ignition switch in "START" position.
- Push purge bulb until fuel is visible in clear fuel return line.
- Pull choke knob up to CLOSE position.
- Pull starter handle until first firing sound.
- Open choke.
- Restart engine and allow to warm up.
- When engine is hard to start, use throttle latch. (Pull throttle trigger fully and lower throttle latch while pressing throttle trigger lockout and release throttle trigger to activate throttle latch. After engine starts, pull throttle trigger slightly to release throttle latch immediately.)

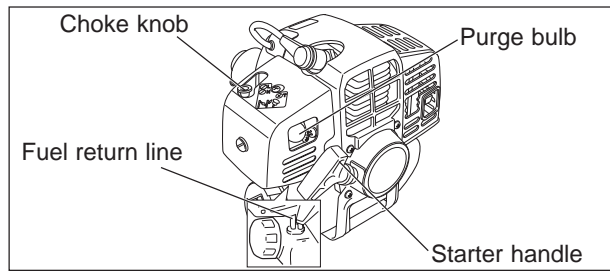

#### NOTE

- Check unit for loose nuts, bolts and screws before starting.
- Always clear work area of debris before starting operation.
- Always hold the unit firmly on the ground.
- When pulling starter handle, use short pulls, 1/2 to 2/3 of rope length.
- Do not allow the starter handle to snap back against the housing.

#### STARTING WARM ENGINE

- Place ignition switch in "START" position.
- Move choke knob to OPEN position.
- If tank is not empty, pull starter handle.
- If fuel tank is empty, after refilling, push the purge bulb (until fuel is visible in clear fuel return line). Pull starter handle.

#### NOTE

If engine does not start after 4 pulls, use Cold Starting Procedure.

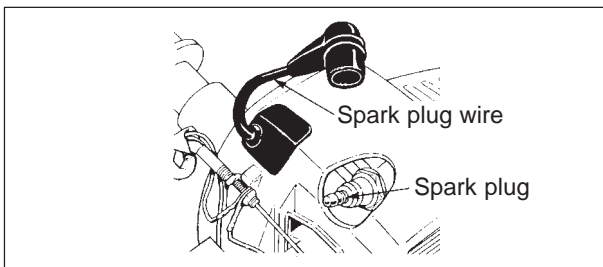

#### STOPPING ENGINE

- Release throttle trigger and allow engine to idle.
- Place ignition switch in "STOP" position.

**WARNING**  **DANGER**  
**IF ENGINE DOES NOT STOP, CLOSE CHOKE TO STALL ENGINE. HAVE YOUR ECHO DEALER INSPECT AND REPAIR IGNITION SWITCH BEFORE USING THE UNIT.**

Always disconnect the spark plug wire from the spark plug to ensure the engine cannot be started before you work on the unit or leave it unattended.

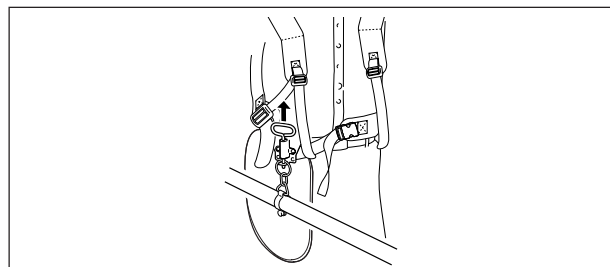

#### USING SHOULDER HARNESS

Place shoulder harness over both shoulders and adjust straps so the connecting point latch as shown.

Buckle waist belt. Belt should be snug.

Attach grasstrimmer/brushcutter to harness.

Check for correct adjustment by moving cutting attachment along ground.

Re-adjust position of suspension point if necessary.

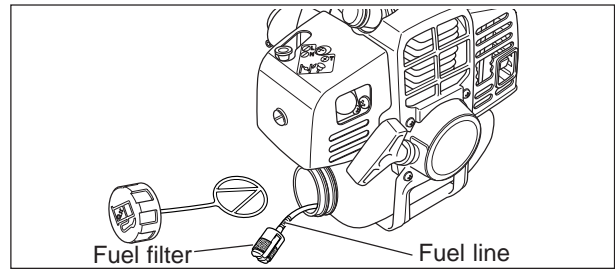
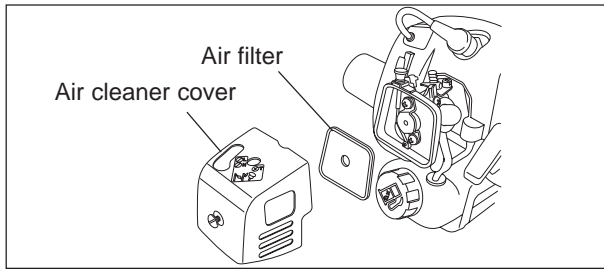

## MAINTENANCE AND CARE

- If you have any questions or problems, please contact your ECHO dealer.

### CLEANING AIR FILTER

- Close choke. Loosen screw and remove air cleaner cover.
- Remove air filter (air filter is located inside air cleaner cover).
- Brush dirt from filter or clean with compressed air.
- Reinstall filter.
- Reinstall cover and tighten screw.

### REPLACING FUEL FILTER

- Use a piece of steel wire or the like to pick up fuel filter through fuel tank opening.
- Pull old filter from fuel line.
- Install new fuel filter.

#### NOTE

If filter is excessive dirty or no longer fits properly, replace it.

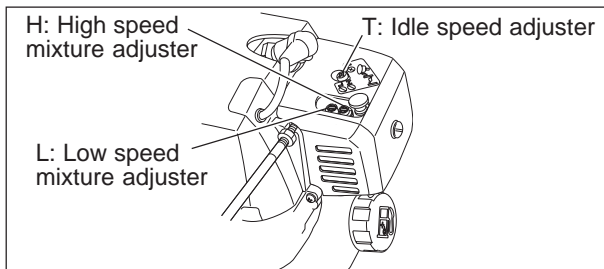

### CARBURETTOR ADJUSTMENT

**WARNING**  **DANGER**  
**WHEN CARBURETTOR ADJUSTMENT IS COMPLETED, CUTTING ATTACHMENT SHOULD NOT MOVE AT IDLE, OTHERWISE SERIOUS PERSONAL INJURY MAY RESULT.**

Every unit is test run at the factory and the carburettor is fine tuned for maximum performance.

Before adjusting carburettor, clean or replace air filter, start engine and run several minutes to bring it to operating temperature.

To adjust the carburettor proceed as follow:

1. Turn the low speed mixture adjuster (L) and high speed mixture adjuster (H) anticlockwise to stop.
2. Start engine and turn "idle" speed adjustment screw (T) clockwise until the cutting attachment begins to turn, then turn the screw (T) anticlockwise until the cutting attachment stops turning. Turn screw (T) anticlockwise an additional 1/4 turn.
3. Accelerate to full throttle for 2 to 3 seconds to clear excess fuel from engine then return to idle. Accelerate to full throttle to check for smooth transition from idle to full throttle.

#### CAUTION

**When starting, idle speed adjuster (T) should be adjusted not to rotate the cutting attachment. When there is some trouble with the carburettor, contact your dealer.**

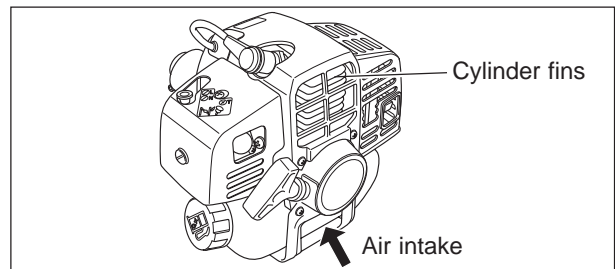

### COOLING SYSTEM MAINTENANCE

#### IMPORTANT

To maintain proper engine operating temperature, cooling air must pass freely through the cylinder fin area. This flow of air carries combustion heat away from the engine.

**Overheating and engine seizure can occur when:**

- **Air intakes are blocked, preventing cooling air from reaching the cylinder,**

**or**

- **Dust and grass build up on the out side of the cylinder. This build-up insulates the engine and prevents the heat from leaving.**

**Removal of cooling passage blockages or cleaning of cylinder fins is considered "Normal Maintenance". Any resultant failure attributed to lack of maintenance is not warranted.**

- Remove dust and dirt from between fins.
- Before each use, remove accumulated debris from bottom engine intake grille located between the fuel tank and starter.

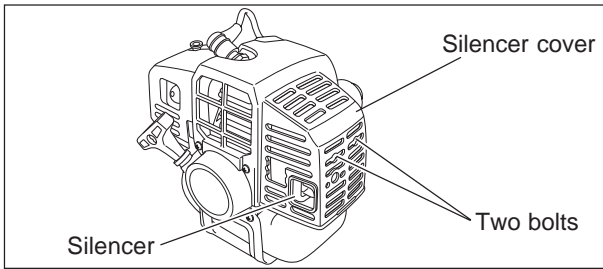

### CLEANING SILENCER

- Clean deposits from silencer and tighten two bolts.

### CHECK FUEL SYSTEM

- Check before every use.
- After refuelling, make sure fuel does not leak or exude from around fuel pipe, fuel grommet or fuel tank cap.
- In case of fuel leakage or exudation there is a danger of fire. Stop using the machine immediately and request your dealer to inspect or replace.

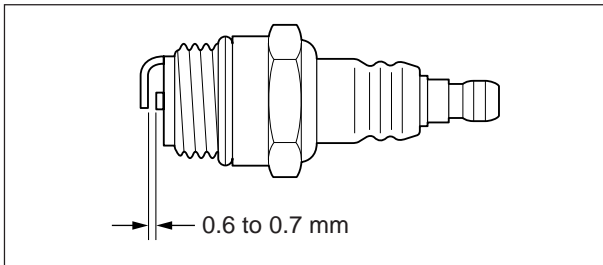

### CHECK SPARK PLUG

- Check plug gap. Correct gap is 0.6 to 0.7 mm.
- Inspect electrode for wear.
- Inspect insulator for oil or other deposits.
- Replace plug if needed and tighten to 15 - 17 N·m (150 to 170 kgf·cm).

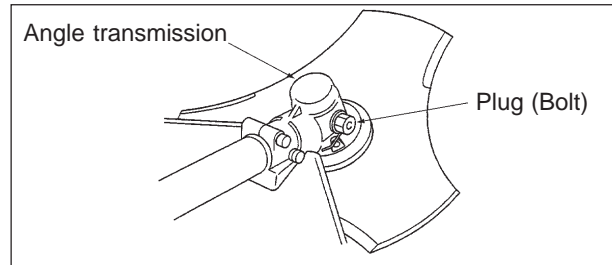

### ANGLE TRANSMISSION

- Remove plug from angle transmission.
- Add grease, if necessary, using low pressure pump.
- Reinstall plug.

#### NOTE

Use good quality lithium multi grease. DO NOT overfill housing.

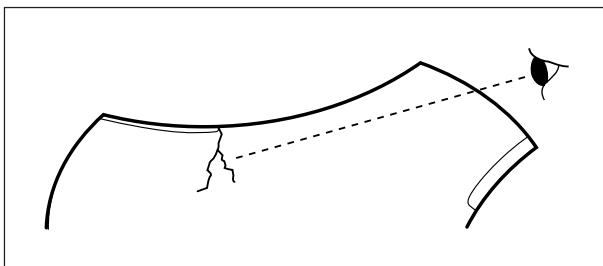

### CHECKING THE BLADE

- Use only the blade designated for this model by the manufacturer.
- When a crack is noticed on the blade, do not use it but replace with a new one.
- Ensure that the blade is correctly fitted in accordance with the instructions.

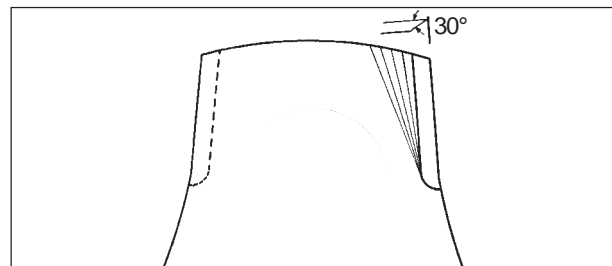

- When the cutting blade becomes dull due to wear reverse it for further use.
- When chip or bend occurs on the blade, vibration will increase. Replace with a new one.
- When filing the blade file 3 cutting edges evenly using a flat file as shown in the illustration. Otherwise, the balance will be lost and vibration will increase.

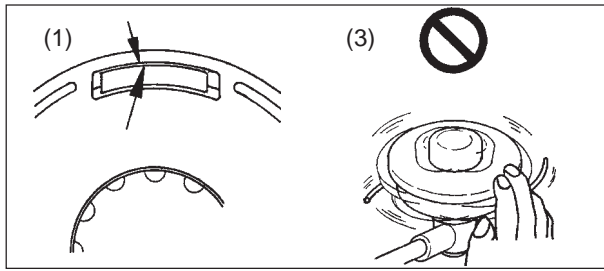

### CHECKING THE NYLON LINE CUTTING ATTACHMENT

- (1) Make sure each periphery of the 2 retaining pawls of housing spreads almost fully up to the outer periphery of the respective cover window.
- (2) Check mount of cutting head on trimmer and tighten if it is loose.
- (3) Check the cutter head for deflection or abnormal noise rotating it by hand.  
Deflection or abnormal noise can cause abnormal vibration to occur or mount to trimmer to loosen during rotation which is dangerous.

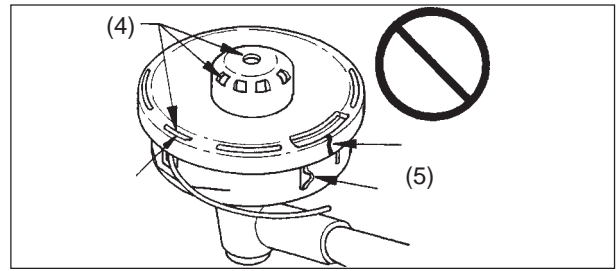

- (4) Inspect cover and tap knob for wear.  
When slot appears on bottom of the tap knob or when slot appears on cover bottom close to outlet for Nylon line, replace them with new parts without fail.
- (5) Check the cutting head for crack or chip.  
Replace parts that show any crack or chip with new ones without fail.

## SERVICING GUIDE

AREA	MAINTENANCE	PAGE	BEFORE USE	MONTHLY
Air Filter	Clean/Replace	19	•	
Fuel Filter	Inspect/Clean/Replace	19	•	
Spark Plug	Inspect/Clean/Adjust/Replace	20		•
Carburettor	Adjust/Replace and adjust	19		•
Cooling System	Inspect/Clean	19	•	
Silencer	Inspect/Tighten/Clean	20	•	
Angle Transmission	Grease	20		•*
Starter Rope	Inspect/Replace	-		•
Cut off Knife	Inspect/Clean	-	•	
Fuel System	Inspect	20	•	
Screws, Bolts and Nuts	Inspect, Tighten/Replace	-	•	

### IMPORTANT

Time intervals are maximum. Actual use and your experience will determine the frequency of required maintenance.

\* Or 50 hours, whichever occurs first.

## TROUBLE SHOOTING

Trouble		Cause	Remedy
Engine	- hard to start - does not start		
Engine cranks	Fuel at carburettor → No fuel at carburettor	<ul style="list-style-type: none"> <li>• Fuel filter clogged</li> <li>• Fuel line clogged</li> <li>• Carburettor</li> </ul>	<ul style="list-style-type: none"> <li>• Clean or replace</li> <li>• Clean</li> <li>• Ask your ECHO dealer</li> </ul>
	↓ Fuel at cylinder → No fuel at cylinder	<ul style="list-style-type: none"> <li>• Carburettor</li> </ul>	<ul style="list-style-type: none"> <li>• Ask your ECHO dealer</li> </ul>
	↓ → Silencer wet with fuel	<ul style="list-style-type: none"> <li>• Fuel mixture is too rich</li> </ul>	<ul style="list-style-type: none"> <li>• Open choke</li> <li>• Clean/replace air filter</li> <li>• Adjust carburettor</li> <li>• Ask your ECHO dealer</li> </ul>
	Spark at end of plug wire → No spark at end of plug wire	<ul style="list-style-type: none"> <li>• Ignition switch off</li> <li>• Electrical problem</li> </ul>	<ul style="list-style-type: none"> <li>• Turn switch on</li> <li>• Ask your ECHO dealer</li> </ul>
	Spark at plug → No spark at plug	<ul style="list-style-type: none"> <li>• Spark gap incorrect</li> <li>• Covered with carbon</li> <li>• Fouled with fuel</li> <li>• Spark plug defective</li> </ul>	<ul style="list-style-type: none"> <li>• Adjust 0.6 to 0.7 mm</li> <li>• Clean or replace</li> <li>• Clean or replace</li> <li>• Replace plug</li> </ul>
Engine does not crank	↓	<ul style="list-style-type: none"> <li>• Internal engine problem</li> </ul>	<ul style="list-style-type: none"> <li>• Ask your ECHO dealer</li> </ul>
Engine runs	Dies or accelerates poorly	<ul style="list-style-type: none"> <li>• Air filter dirty</li> <li>• Fuel filter dirty</li> <li>• Fuel vent plugged</li> <li>• Spark plug</li> <li>• Carburettor</li> <li>• Cooling system plugged</li> <li>• Exhaust port/silencer plugged</li> </ul>	<ul style="list-style-type: none"> <li>• Clean or replace</li> <li>• Clean or replace</li> <li>• Clean</li> <li>• Clean and adjust/replace</li> <li>• Adjust</li> <li>• Clean</li> <li>• Clean</li> </ul>

### WARNING DANGER

- ALL TRIMMER SERVICE OPERATIONS, OTHER THAN ITEMS LISTED IN THE OPERATOR'S MANUAL, SHOULD BE PERFORMED BY COMPETENT SERVICE PERSONNEL.
- FUEL VAPORS ARE EXTREMELY FLAMMABLE AND MAY CAUSE FIRE AND/OR EXPLOSION. NEVER TEST FOR IGNITION SPARK BY GROUNDING SPARK PLUG NEAR CYLINDER PLUG HOLE, OTHERWISE SERIOUS PERSONAL INJURY MAY RESULT.

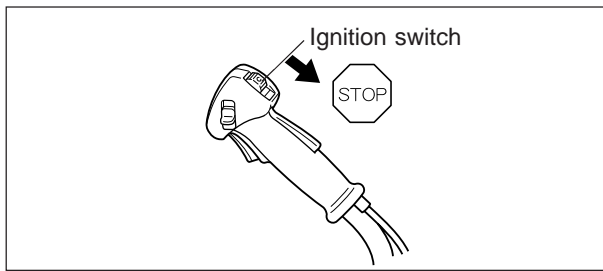

## STORAGE

### LONG TERM STORAGE (Over 30 Days)

**WARNING**  **DANGER**  
**DO NOT STORE IN AN ENCLOSURE WHERE FUEL FUMES MAY ACCUMULATE OR REACH AN OPEN FLAME OR SPARK.**

Do not store your unit for a prolonged period of time (30 days or longer) without performing protective storage maintenance which includes the following:

1. Store unit in a dry, dust free place, out of the reach of children and other unauthorized persons.
2. Place ignition switch in "STOP" position.
3. Remove accumulation of grease, oil, dirt and debris from exterior of unit.
4. Perform all periodic lubrication and services that are required.
5. Tighten all the screws, bolts and nuts.
6. Drain the fuel tank completely and pull the recoil starter handle several times to remove fuel from the carburettor.
7. Remove the spark plug and pour 1/2 tablespoon of fresh, clean, two-stroke engine oil into the cylinder through the spark plug hole.
  - A. Place a clean cloth over the spark plug hole.
  - B. Pull the recoil starter handle 2 or 3 times to distribute the oil inside the engine.
  - C. Observe the piston location through the spark plug hole. Pull the recoil starter handle slowly until the piston reaches the top of its travel and leave it there.
8. Install the spark plug (Do not connect ignition cable).



### NOTE

- For future reference, you should keep this operator's manual.
- If this operator's manual has become illegible through impairment or is lost, please purchase a new one from your ECHO dealer.
- When renting or lending this machine to a person who will operate it, always include this operator's manual, which provides explanation and instructions.
- When transferring a product, please deliver it attaching the operator's manual.

## SPECIFICATIONS

		<b>SRM-2305</b>
<b>Mass :</b> unit without cutting attachment, empty tank unit with specified cutting attachment, empty tank unit with specified cutting attachment, full tank	kg kg kg	5.6 6.0 6.3
<b>Volume :</b> fuel tank	L	0.4
<b>Cutting attachment :</b> specified blade diameter specified blade thickness number of cutting teeth blade centre hole diameter blade rotational speed at maximum allowable engine speed	mm mm  mm r/min	230 2.0 3 25.4 10,000
<b>Gear ratio :</b> gear ratio and lubrication		1.36 reduction and good quality lithium grease
<b>Rotational direction of output shaft seen from above :</b>		Anticlockwise
<b>External dimensions :</b> length x width x height	mm	1,760 x 690 x 455
<b>Engine :</b> type engine displacement maximum shaft brake power, measured in accordance with ISO 8893 engine speed at maximum engine power recommended maximum engine speed output shaft speed recommended engine idling speed engine speed at beginning of clutch engagement carburettor ignition spark plug starter clutch	mL(cm <sup>3</sup> )  kW r/min r/min r/min r/min r/min	Air cooled two stroke single cylinder 21.2  0.57 7,500 10,000 - 3,000 3,700 Diaphragm type Flywheel magneto - CDI system NGK BPMR7A Recoil starter Automatic centrifugal clutch
<b>Fuel :</b>  oil  ratio fuel consumption at maximum engine power specific fuel consumption at maximum engine power	    L/h g/(kW-h)	Regular grade petrol. Minimum 89 Octane unleaded petrol is recommended. Do not use fuel containing methyl alcohol or more than 10 % of ethyl alcohol. Two stroke, air-cooled engine oil. 50 : 1 for ISO-L-EGD Standard (ISO/CD 13738), JASO FC grade and ECHO Premium 50 : 1 oil. 50 : 1 (2 %) 0.56 737
<b>Sound pressure level :</b> (EN 27917) L <sub>pAav</sub> =	dB(A)	92
<b>Sound power level :</b> (2000/14/EC) L <sub>wA</sub> =	dB(A)	108
<b>Vibration levels :</b> (ISO 7916) idling racing	m/s <sup>2</sup> m/s <sup>2</sup>	4.0 7.1

Specifications, descriptions and illustrative material in this literature are as accurate as known at the time of publication, but are subject to change without notice.

Illustrations may include optional equipment and accessories, and may not include all standard equipment.



# DECLARATION "CE" OF CONFORMITY

The undersigned manufacturer:

**KIORITZ CORPORATION  
7-2 SUEHIROCHO 1-CHOME  
OHME ; TOKYO 198-8711  
JAPAN**

declares that the hereunder specified new unit:

## **GRASS-TRIMMER/BRUSHCUTTER**

Brand : **ECHO**  
Type : **SRM-2305**

complies with:

- \* the requirements of Directive **98/37/EC (1998)**  
(use of harmonized standard **ISO 11806 (EN 31806)**)
  
- \* the requirements of Directive **89/336/EEC**  
(use of harmonized standards **EN 50081-1, EN 50082-1, EN 55014 & EN 55022**)
  
- \* the requirements of Directive **2002/88/EC**
  
- \* the requirements of Directive **2000/14/EC**  
Conformity assessment procedure followed **ANNEX V**  
Measured sound power level : **105 dB(A)**  
Guaranteed sound power level : **108 dB(A)**

Tokyo,  
April, 1st 2004

**KIORITZ CORPORATION**

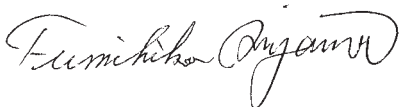

**F. AIYAMA, GENERAL MANAGER**





# KIORITZ CORPORATION

7-2 SUEHIROCHO 1-CHOME, OHME, TOKYO 198-8711, JAPAN  
PHONE: 81-428-32-6118. FAX: 81-428-32-6145.

**ECHO**<sup>®</sup>

## Free Manuals Download Website

<http://myh66.com>

<http://usermanuals.us>

<http://www.somanuals.com>

<http://www.4manuals.cc>

<http://www.manual-lib.com>

<http://www.404manual.com>

<http://www.luxmanual.com>

<http://aubethermostatmanual.com>

Golf course search by state

<http://golfingnear.com>

Email search by domain

<http://emailbydomain.com>

Auto manuals search

<http://auto.somanuals.com>

TV manuals search

<http://tv.somanuals.com>